

Electrical Power Technology
Using Data Acquisition

AC/DC Motors and Generators

30329-00



Lab-Volt[®]

DC Motors and Generators

UNIT OBJECTIVE

After completing this unit, you will be able to use the DC Motor / Generator module to demonstrate and explain the operation of dc motors and generators.

DISCUSSION OF FUNDAMENTALS

Operating Principle of DC Motors

As stated in Unit 1, motors turn because of the interaction between two magnetic fields. This unit will discuss how these magnetic fields are produced in dc motors, and how magnetic fields induce voltage in dc generators.

The basic principle of a dc motor is the creation of a rotating magnet inside the mobile part of the motor, the rotor. This is accomplished by a device called the **commutator** which is found on all dc machines. The commutator produces the alternating currents necessary for the creation of the rotating magnet from dc power provided by an external source. Figure 2-1 illustrates a typical dc motor rotor with its main parts. This figure shows that the electrical contact between the segments of the commutator and the external dc source is made through brushes. Note that the rotor of a dc motor is also referred to as the armature.

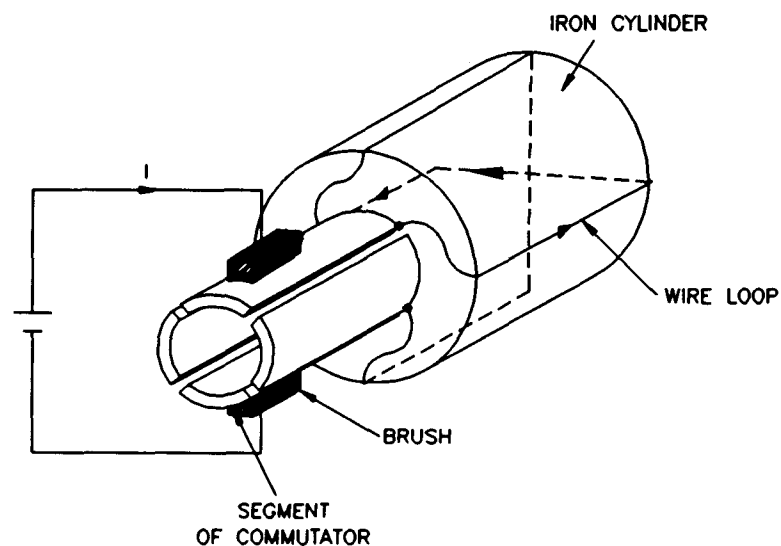

Figure 2-1. The Main Parts of a DC Motor Rotor (Armature).

DC Motors and Generators

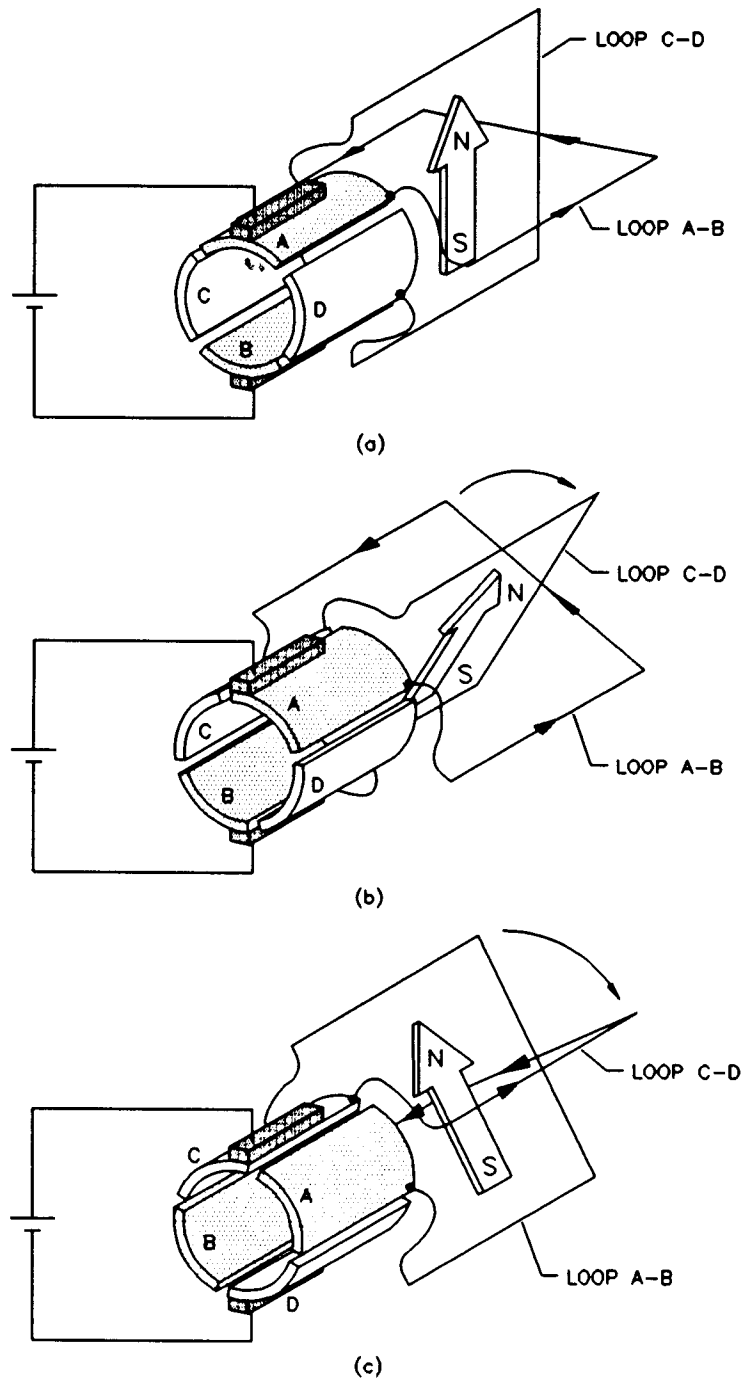

Figure 2-2. Operation of the Commutator.

In Figure 2-2 (a), the brushes make contact with segments A and B of the commutator and current flows in wire loop A-B. No current flows in the other wire loop (C-D). This creates an electromagnet A-B with north and south poles as shown in Figure 2-2 (a). If the rotor is turned clockwise a little as shown in Figure 2-2 (b), current still flows in wire loop A-B and the magnetic north and

DC Motors and Generators

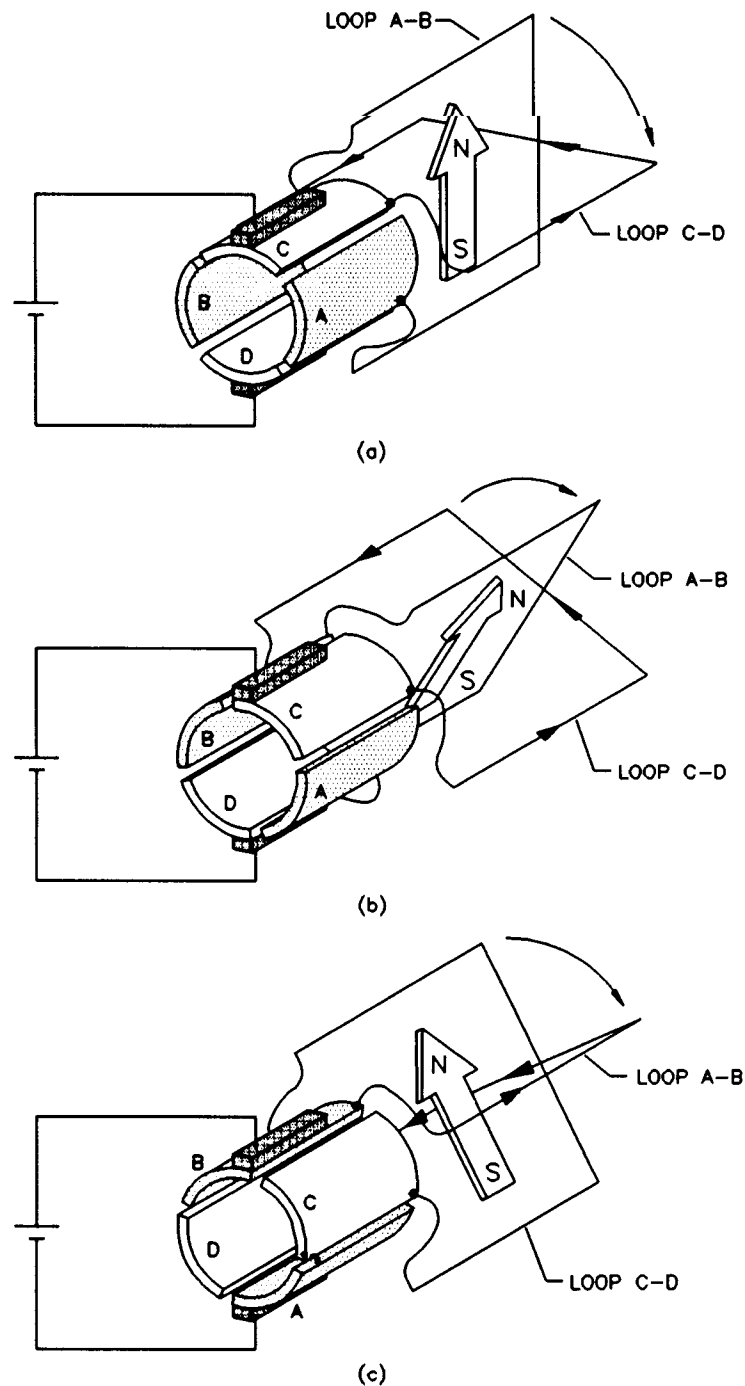

Figure 2-3. Operation of the Commutator (continued).

south poles rotate clockwise. As the rotor continues to rotate clockwise, a time comes where a commutation occurs, i.e. the brushes make contact with segments C and D instead of segments A and B, as shown in Figure 2-2 (c). As a result, current now flows in wire loop C-D instead of flowing in wire loop A-B. This creates an electromagnet C-D with north and south poles as shown in

DC Motors and Generators

Figure 2-2 (c). By comparing Figures 2-2 (b) and (c), you can see that the magnetic north and south poles rotate 90° counterclockwise at the commutation. As the rotor continues to rotate clockwise, the same phenomenon repeats every 90° angle of rotation as shown in Figures 2-3 (a) to (c).

In brief, as the rotor turns, the north and south poles of the electromagnet go back and forth (oscillate) over a 90° angle as shown in Figure 2-4. In other words, the north and south poles are stationary, i.e. they do not rotate as the rotor turns. This is equivalent to having an electromagnet in the rotor that rotates at the same speed as the rotor but in the opposite direction. The higher the number of segments on the commutator, the lower the angle of rotation between each commutation, and the lower the angle over which the north and south poles oscillate. For example, the north and south poles would oscillate over an angle of only 11.25° if the commutator in Figures 2-2 to 2-4 were having 32 segments.

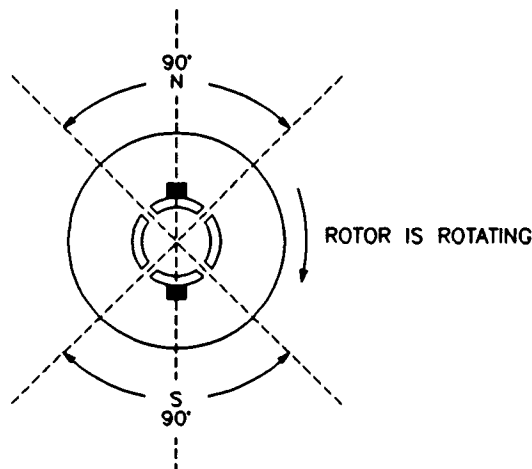

Figure 2-4. The North and South Poles Oscillate Around a Fixed Position.

If this rotor is placed next to a fixed permanent magnet **stator** as shown in Figure 2-5, the magnetic poles of opposite polarity attract each other (in order to align) and the rotor starts to turn. After the rotor has turned of a certain angle, a commutation occurs and the north and south poles of the electromagnet go back. Once again, the magnetic poles of opposite polarity attract each other, and the rotor continues to rotate in the same direction so as to align the magnetic poles of opposite polarity. However, another commutation occurs a little after and the north and south poles of the electromagnet go back once again. This cycle repeats over and over. The force that results from the interaction of the two magnetic fields always acts in the same direction, and the rotor turns continually. Thus, a converter of electrical-to-mechanical energy, i.e. an electric motor, has been achieved. The direction of rotation depends on the polarity of the voltage applied to the brushes of the rotor.

DC Motors and Generators

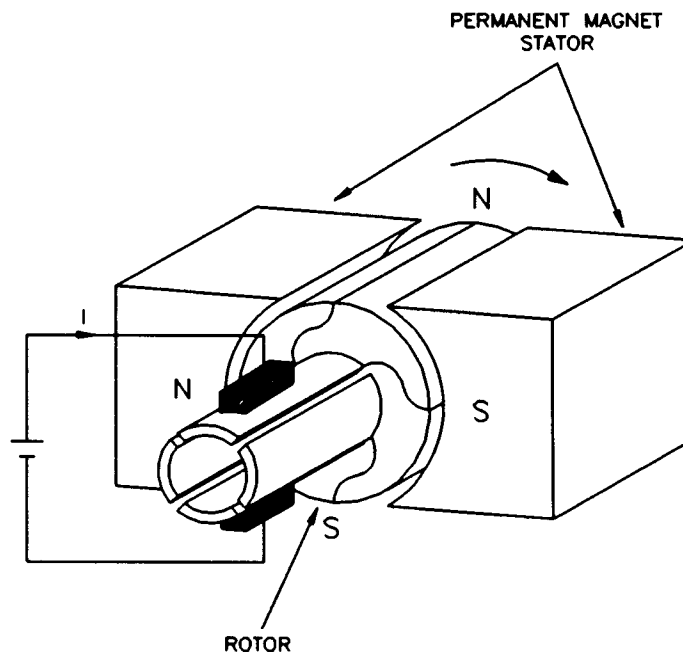

Figure 2-5. Rotation Resulting from Interaction of Magnetic Fields in the Stator and the Rotor.

Operating Principle of DC Generators

Previously, we saw that the variation of magnetic flux in a coil of wire caused a voltage to be induced between the ends of the coil of wire. If a wire loop is placed between two magnets and rotated as shown in Figure 2-6, magnetic lines of force are cut and a voltage "e" is induced in the loop. The polarity of the induced voltage "e" depends on the direction in which the wire loop moves as it cuts the magnetic lines of force. Since the wire loop cuts magnetic lines of force in both direction within a full revolution, the induced voltage is an ac voltage similar to that shown in Figure 2-6.

If a commutator such as that shown in Figure 2-1 is used, it will act as a **rectifier** and convert the induced ac voltage into a dc voltage (with ripple) as shown in Figure 2-6. Direct current will therefore be produced at the output of the generator. The faster the rotor turns, the more lines of force that are cut and the higher the output voltage. Also, the stronger the stator magnet, the more lines of force that are present, and therefore, the higher the output voltage.

DC Motors and Generators

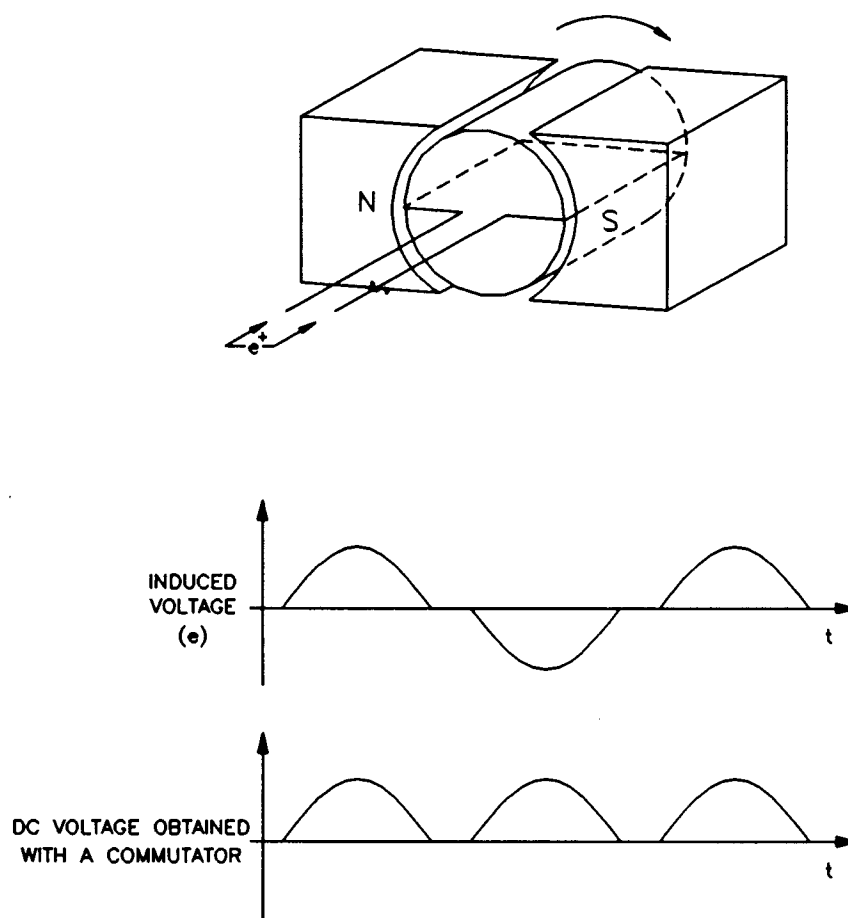

Figure 2-6. A Coil Rotating in a Magnetic Field Results in an Induced Voltage.

Exercise 2-1

The Separately-Excited DC Motor

EXERCISE OBJECTIVE

When you have completed this exercise, you will be able to demonstrate the main operating characteristics of a separately-excited dc motor using the DC Motor / Generator module.

DISCUSSION

Previously, you saw that a dc motor is made up basically of a fixed magnet (stator) and a rotating magnet (rotor). Many dc motors use an electromagnet for the stator, as illustrated in Figure 2-7.

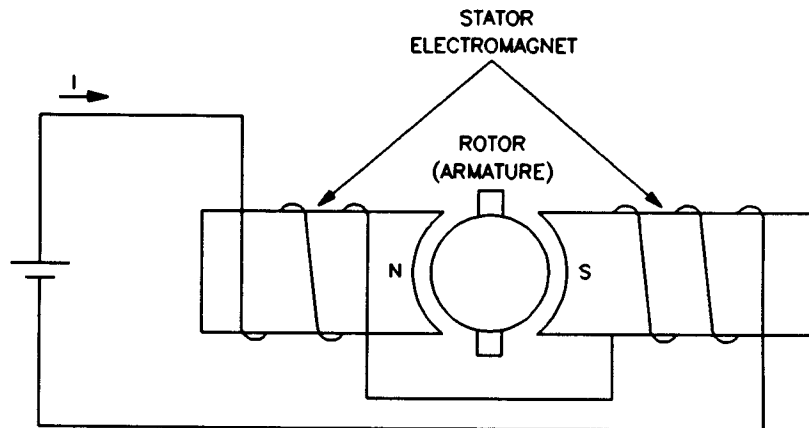

Figure 2-7. Simplified DC Motor with an Electromagnet as Stator.

When power for the stator electromagnet is supplied by a separate dc source, either fixed or variable, the motor is known as a separately-excited dc motor. Sometimes the term independent-field dc motor is also used. The current flowing in the stator electromagnet is often called **field current** because it is used to create a fixed magnetic field. The electrical and mechanical behaviour of the dc motor can be understood by examining its simplified equivalent electric circuit shown in Figure 2-8.

The Separately-Excited DC Motor

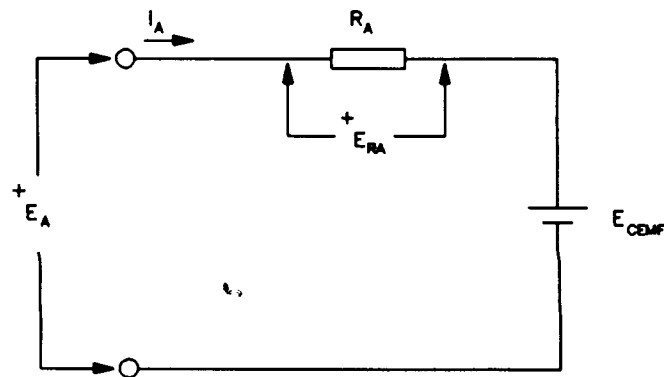

Figure 2-8. Simplified Equivalent Circuit of a DC Motor.

In the circuit, E_A is the voltage applied to the motor brushes, I_A is the current flowing through the brushes, and R_A is the resistance between the brushes. Note that E_A , I_A , and R_A are usually referred to as the armature voltage, current, and resistance, respectively. E_{RA} is the voltage drop across the armature resistor. When the motor turns, an induced voltage E_{CEMF} proportional to the speed of the motor is produced. This induced voltage is represented by a dc source in the simplified equivalent circuit of Figure 2-8. The motor also develops a torque T proportional to the armature current I_A flowing in the motor. The motor behaviour is based on the two equations given below. The first relates motor speed n and the induced voltage E_{CEMF} , and the second relates the motor torque T and the armature current I_A .

$$n = K_1 \times E_{CEMF} \quad \text{and} \quad T = K_2 \times I_A$$

where K_1 is a constant expressed in units of r/min/V,
 K_2 is a constant expressed in units of N·m/A or lbf·in/A.

When a voltage E_A is applied to the armature of a dc motor with no mechanical load, the armature current I_A flowing in the equivalent circuit of Figure 2-8 is constant and has a very low value. As a result, the voltage drop E_{RA} across the armature resistor is so low that it can be neglected, and E_{CEMF} can be considered to be equal to the armature voltage E_A . Therefore, the relationship between the motor speed n and the armature voltage E_A is a straight line because E_{CEMF} is proportional to the motor speed n . This linear relationship is illustrated in Figure 2-9, and the slope of the straight line equals constant K_1 .

The Separately-Excited DC Motor

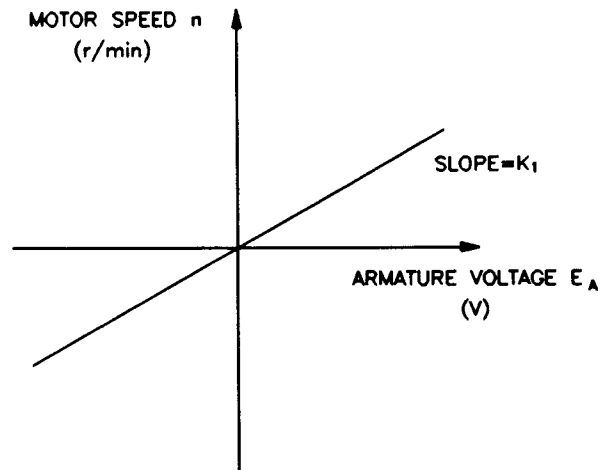

Figure 2-9. Linear Relationship Between the Motor Speed and the Armature Voltage.

Since the relationship between voltage E_A and speed n is linear, a dc motor can be considered to be a linear voltage-to-speed converter as shown in Figure 2-10.

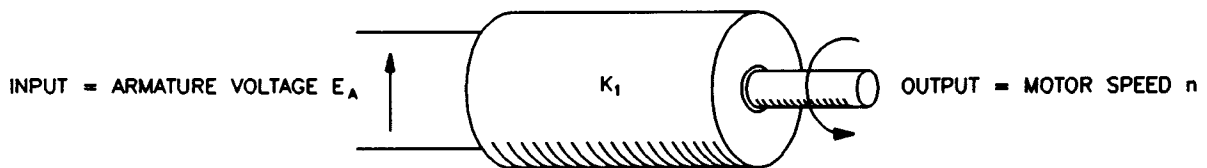

Figure 2-10. DC Motor as a Voltage-to-Speed Converter.

The same type of relationship exists between the motor torque T and the armature current I_A , so that a dc motor can also be considered as a linear current-to-torque converter. Figure 2-11 illustrates the linear relationship between the motor torque T and the armature current I_A . Constant K_2 is the slope of the line relating the two. In Figure 2-12, the linear current-to-torque converter is illustrated.

The Separately-Excited DC Motor

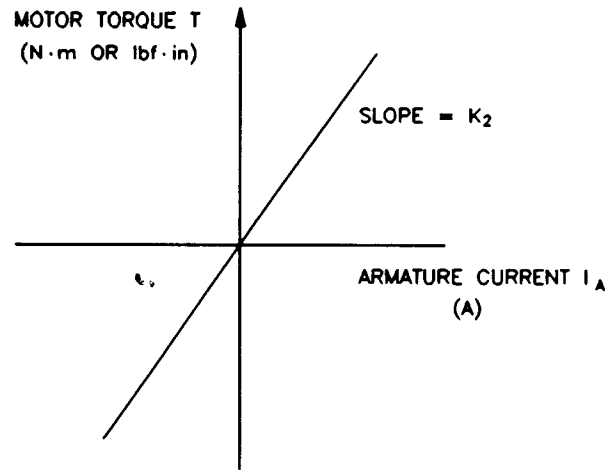

Figure 2-11. Linear Relationship Between the Motor Torque and the Armature Current.

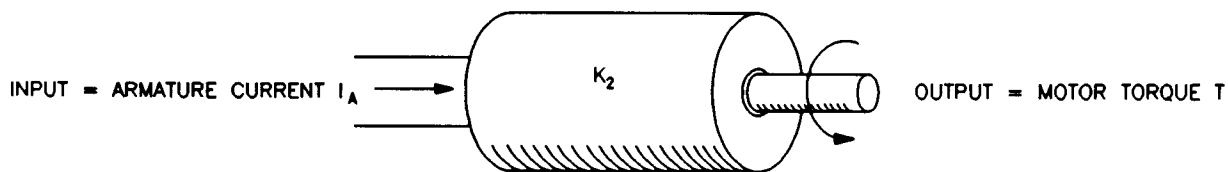

Figure 2-12. DC Motor as a Current-to-Torque Converter.

When the armature current I_A increases, the voltage drop E_{RA} ($R_A \times I_A$) across the armature resistor also increases and can no longer be neglected. As a result, the armature voltage E_A can no longer be considered to be equal to E_{CEMF} , but rather the sum of E_{CEMF} and E_{RA} as indicated in the following equation:

$$E_A = E_{CEMF} + E_{RA}$$

Therefore, when a fixed armature voltage E_A is applied to a dc motor, the voltage drop E_{RA} across the armature resistor increases as the armature current I_A increases, and thereby, causes E_{CEMF} to decrease. This also causes the motor speed n to decrease because it is proportional to E_{CEMF} . This is shown in Figure 2-13 which is a graph of the motor speed n versus the armature current I_A for a fixed armature voltage E_A .

The Separately-Excited DC Motor

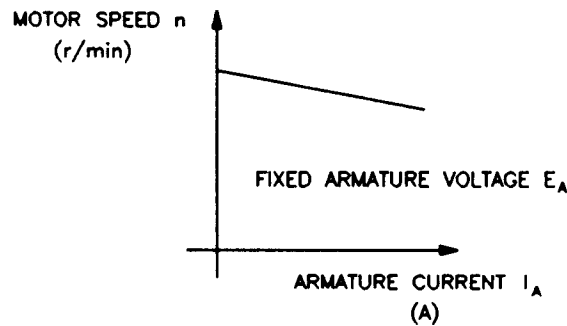

Figure 2-13. Motor Speed Drop as the Armature Current Increases (Fixed Armature Voltage E_A).

Procedure Summary

In the first part of the exercise, you will set up the equipment in the Workstation, connect the equipment as shown in Figure 2-14, and make the appropriate settings on the Prime Mover / Dynamometer.

In the second part of the exercise, you will measure the armature resistance R_A of the DC Motor / Generator. It is not possible to measure the armature resistance R_A directly with a conventional ohmmeter because the non-linear characteristic of the motor brushes causes incorrect results when I_A is too small. The general method used to determine the armature resistance R_A consists in connecting a dc power source to the motor armature and measuring the voltage required to produce nominal current flow in the armature windings. Power is not connected to the stator electromagnet to ensure that the motor does not turn, thus E_{CEMF} equals zero. The ratio of the armature voltage E_A to the armature current I_A yields the armature resistance R_A directly.

Note: *The motor will not start to rotate because it is mechanically loaded.*

In the third part of the exercise, you will measure data and plot a graph of the motor speed n versus the armature voltage E_A to demonstrate that the speed of the separately-excited dc motor is proportional to the armature voltage E_A under no-load conditions.

In the fourth part of the exercise, you will measure data and plot a graph of the motor torque T versus the armature current I_A to demonstrate that the torque of the separately-excited dc motor is proportional to the armature current I_A .

In the fifth part of the exercise, you will demonstrate that when the armature voltage E_A is set to a fixed value, the speed of the separately-excited dc motor decreases with increasing armature current or torque because of the increasing voltage drop across the armature resistor.

The Separately-Excited DC Motor

EQUIPMENT REQUIRED

Refer to the Equipment Utilization Chart in Appendix C to obtain the list of equipment required for this exercise.

PROCEDURE

CAUTION!

High voltages are present in this laboratory exercise! Do not make or modify any banana jack connections with the power on unless otherwise specified!

Setting up the Equipment

- 1. Install the Power Supply, Prime Mover / Dynamometer, DC Motor / Generator, and Data Acquisition Interface modules in the EMS workstation.

Note: If you are performing the exercise using the EMS system, ensure that the brushes of the DC Motor/Generator are adjusted to the neutral point. To do so, connect an ac power source (terminals 4 and N of the Power Supply) to the armature of the DC Motor/Generator (terminals 1 and 2) through CURRENT INPUT I1 of the Data Acquisition Interface module. Connect the shunt winding of the DC Motor/Generator (terminals 5 and 6) to VOLTAGE INPUT E1 of the Data Acquisition Interface module. Start the Metering application and open setup configuration file ACMOTOR1.CFG. Turn on the Power Supply and set the voltage control knob so that an ac current (indicated by meter I1) equal to half the nominal value of the armature current flows in the armature of the DC Motor/Generator. Adjust the brushes adjustment lever on the DC Motor/Generator so that the voltage across the shunt winding (indicated by meter E1) is minimum. Turn off the Power Supply, exit the Metering application, and disconnect all leads and cable.

Mechanically couple the Prime Mover / Dynamometer to the DC Motor / Generator using a timing belt.

- 2. On the Power Supply, make sure the main power switch is set to the O (off) position, and the voltage control knob is turned fully counterclockwise. Ensure the Power Supply is connected to a three-phase power source.
- 3. Ensure that the flat cable from the computer is connected to the DAI module.

Connect the LOW POWER INPUTs of the DAI and Prime Mover / Dynamometer modules to the 24 V - AC output of the Power Supply.

The Separately-Excited DC Motor

On the Power Supply, set the 24 V - AC power switch to the I (on) position.

- 4. Start the Metering application.

In the Metering application, open setup configuration file DCMOTOR1.CFG then select custom view 2.

- 5. Set up the separately-excited dc motor circuit shown in Figure 2-14. Leave the circuit open at points A and B shown in the figure.

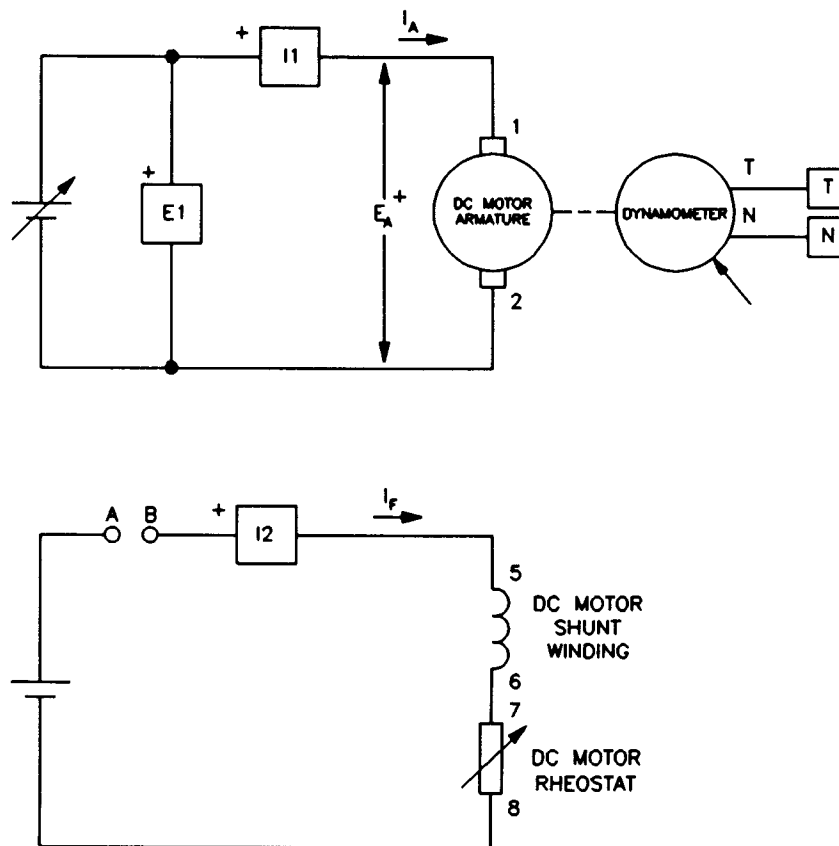

Figure 2-14. Separately-Excited DC Motor Coupled to a Dynamometer.

- 6. Set the Prime Mover / Dynamometer controls as follows:

| | | |
|--------------------------|-------|-----------------|
| MODE switch | | DYN. |
| LOAD CONTROL MODE switch | | MAN. |
| LOAD CONTROL knob | | MAX. (fully CW) |
| DISPLAY switch | | SPEED (N) |

The Separately-Excited DC Motor

Note: If you are performing the exercise using LVSIM™-EMS, you can zoom in the Prime Mover / Dynamometer module before setting the controls in order to see additional front panel markings related to these controls.

Determining the Armature Resistance

- 7. Turn on the Power Supply by setting its main power switch to the I (on) position, and set the voltage control knob so that the rated armature current flows in the DC Motor / Generator. The armature current is indicated by meter I1 in the Metering application.

Note: The rating of any of the Lab-Volt machines is indicated in the lower left corner of the module front panel. If you are performing the exercise using LVSIM™-EMS, you can obtain the rating of any machine by leaving the mouse pointer on the rotor of the machine of interest. Pop-up help indicating the machine rating will appear after a few seconds.

Record the value of armature resistance R_A indicated by programmable meter B.

$$R_A = \text{_____ } \Omega$$

- 8. Turn the voltage control knob fully counterclockwise and turn off the Power Supply by setting its main power switch to the O (off) position.

Interconnect points A and B shown in the circuit of Figure 2-14.

Motor Speed Versus Armature Voltage

- 9. Turn on the Power Supply.

On the Prime Mover / Dynamometer, set the LOAD CONTROL knob to the MIN. position (fully CCW).

On the DC Motor / Generator, set the FIELD RHEOSTAT so that the current indicated by meter I2 in the Metering application is equal to the value given in the following table:

| LINE VOLTAGE | FIELD CURRENT I_f |
|--------------|------------------------|
| V ac | mA |
| 120 | 300 |
| 220 | 190 |
| 240 | 210 |

Table 2-1. DC Motor Field Current.

The Separately-Excited DC Motor

- 10. In the Metering application, select the torque correction function for meter T. Meter T now indicates the dc motor output torque. Record the dc motor speed n , armature voltage E_A , armature current I_A , field current I_F , and output torque T (indicated by meters N, E1, I1, I2, and T, respectively) in the Data Table.

On the Power Supply, set the voltage control knob to 10%, 20%, 30% etc. up to 100% in order to increase the armature voltage E_A by steps. For each voltage setting, wait until the motor speed stabilizes, and then record the data in the Data Table.

Note: If you are performing the exercise using LVSIM™-EMS, click the button located beside the Power Supply display until the % inscription appears in this button. This will cause the Power Supply display to indicate the position of the voltage control knob in percentage values.

- 11. When all data has been recorded, turn the voltage control knob fully counterclockwise and turn off the Power Supply.

In the Data Table window, confirm that the data has been stored, edit the data table so as to keep only the values of the dc motor speed n , armature voltage E_A , armature current I_A , field current I_F , and output torque T (data in columns N, E1, I1, I2, and T, respectively), entitle the data table as DT211, and print the data table.

Note: Refer to Appendix E of this manual to know how to edit, entitle, and print a data table.

- 12. In the Graph window, make the appropriate settings to obtain a graph of the dc motor speed n (obtained from meter N) as a function of the armature voltage E_A (obtained from meter E1). Entitle the graph as G211, name the x-axis as Armature Voltage, name the y-axis as DC Motor Speed, and print the graph.

Note: Refer to Appendix E of this manual to know how to use the Graph window of the Metering application to obtain a graph, entitle a graph, name the axes of a graph, and print a graph.

What kind of relationship exists between the armature voltage E_A and the dc motor speed n ?

Does this graph confirm that the separately-excited dc motor is equivalent to a linear voltage-to-speed converter, with higher voltage producing greater speed?

- Yes No

The Separately-Excited DC Motor

13. Use the two end points to calculate the slope K_1 of the relationship obtained in graph G211. The values of these points are indicated in data table DT211.

$$K_1 = \frac{n_2 - n_1}{E_2 - E_1} = \frac{\text{r/min}}{\text{V}}$$

In the Data Table window, clear the recorded data.

Motor Torque Versus Armature Current

14. Turn on the Power Supply.

On the DC Motor / Generator, slightly readjust the FIELD RHEOSTAT so that the current indicated by meter I2 in the Metering application still equals the value given in Table 2-1 (if necessary).

On the Power Supply, set the voltage control knob so that the dc motor speed is 1500 r/min. Note the value of the armature voltage E_A in the following blank space.

$$E_A = \text{_____ V} \quad (n = 1500 \text{ r/min})$$

15. In the Metering application, record the dc motor output torque T , armature voltage E_A , armature current I_A , field current I_F , and speed n (indicated by meters T, E1, I1, I2, and n, respectively) in the Data Table.

On the Prime Mover / Dynamometer, set the DISPLAY switch to the TORQUE (T) position then adjust the LOAD CONTROL knob so that the torque indicated on the module display increases by 0.2 N·m (2.0 lbf-in) increments up to 2.0 N·m (18.0 lbf-in). For each torque setting, readjust the voltage control knob of the Power Supply so that the armature voltage E_A remains equal to the value recorded in the previous step, then record the data in the Data Table.

Note: The armature current may exceed the rated value while performing this manipulation. It is, therefore, suggested to complete the manipulation within a time interval of 5 minutes or less.

16. When all data has been recorded, set the LOAD CONTROL knob on the Prime Mover / Dynamometer to the MIN. position (fully CCW), turn the voltage control knob fully counterclockwise, and turn off the Power Supply.

In the Data Table window, confirm that the data has been stored, edit the table so as to keep only the values of the dc motor torque T , armature voltage E_A , armature current I_A , field current I_F , and speed n (data in columns T, E1, I1, I2, and N respectively), entitle the data table as DT212, and print the data table.

The Separately-Excited DC Motor

17. In the Graph window, make the appropriate settings to obtain a graph of the dc motor torque (obtained from meter T) as a function of the armature current I_A (obtained from meter I1). Entitle the graph as G212, name the x-axis as Armature Current, name the y-axis as DC Motor Torque, and print the graph.

What kind of relationship exists between the armature current I_A and the dc motor torque T as long as the armature current does not exceed the nominal value?

Does this graph confirm that the separately-excited dc motor is equivalent to a linear current-to-torque converter (when the armature current does not exceed the nominal value), with higher current producing greater torque?

- Yes No

Note: The torque versus current relationship is no longer linear when the armature current exceeds the nominal value because of a phenomenon called armature reaction. This phenomenon is described in the next unit of this manual.

18. Use the two end points of the linear portion of the relationship obtained in graph G212 to calculate the slope K_2 . The values of these points are indicated in data table DT212.

$$K_2 = \frac{T_2 - T_1}{I_2 - I_1} = \frac{\text{N}\cdot\text{m (lbf}\cdot\text{in)}}{\text{A}}$$

Speed Decrease Versus Armature Current

19. Using the armature resistance R_A and the constant K_1 determined previously in this exercise, the armature voltage E_A measured in step 14, and the set of equations given below, determine the dc motor speed n for each of the three armature currents I_A given in Table 2-2.

$$E_{RA} = I_A \times R_A$$

$$E_{CEMF} = E_A - E_{RA}$$

$$n = E_{CEMF} \times K_1$$

The Separately-Excited DC Motor

| LINE VOLTAGE | ARMATURE CURRENT I_A | ARMATURE CURRENT I_A | ARMATURE CURRENT I_A |
|--------------|---------------------------|---------------------------|---------------------------|
| V ac | A | A | A |
| 120 | 1.0 | 2.0 | 3.0 |
| 220 | 0.5 | 1.0 | 1.5 |
| 240 | 0.5 | 1.0 | 1.5 |

Table 2-2. DC Motor Armature Currents.

When I_A equals ____ A:

$$E_{RA} = \text{____} \text{ V}$$

$$E_{CEMF} = \text{____} \text{ V}$$

$$n = \text{____} \text{ r/min}$$

When I_A equals ____ A:

$$E_{RA} = \text{____} \text{ V}$$

$$E_{CEMF} = \text{____} \text{ V}$$

$$n = \text{____} \text{ r/min}$$

When I_A equals ____ A:

$$E_{RA} = \text{____} \text{ V}$$

$$E_{CEMF} = \text{____} \text{ V}$$

$$n = \text{____} \text{ r/min}$$

Based on your calculations, how should E_{CEMF} and the dc motor speed n vary as the armature current is increased?

20. In the Graph window, make the appropriate settings to obtain a graph of the dc motor speed (obtained from meter N) as a function of the armature current I_A (obtained from meter I1) using the data recorded previously in the data table (DT212). Entitle the graph as G212-1, name the x-axis as Armature Current, name the y-axis as DC Motor Speed, and print the graph.

The Separately-Excited DC Motor

Does graph G212-1 confirm the prediction you made in the previous step about the variation of the dc motor speed as a function of the armature current I_A ?

- Yes No

Briefly explain what causes the dc motor speed to decrease when the armature voltage E_A is fixed and the armature current I_A increases.

21. In the Graph window, make the appropriate settings to obtain a graph of the dc motor speed (obtained from meter N) as a function of the dc motor torque T (obtained from meter T) using the data recorded previously in the data table (DT212). Entitle the graph as G212-2, name the x-axis as Separately-Excited DC Motor Torque, name the y-axis as Separately-Excited DC Motor Speed, and print the graph. This graph will be used in the next exercise of this unit.
22. Set the 24 V - AC power switch to the O (off) position, and remove all leads and cables.

ADDITIONAL EXPERIMENTS

Speed-Voltage and Torque-Current Graphs for Reversed Armature Connections

You can obtain graphs of the dc motor speed n versus the armature voltage E_A , and dc motor torque T versus the armature current I_A , with reversed armature connections. To do so, make sure the Power Supply is turned off and reverse the connection of the leads at terminals 1 and 2 (armature) of the DC Motor/Generator. Refer to steps 6 to 17 of this exercise to record the necessary data and obtain the graphs. This will allow you to verify that the linear relationships between the speed and armature voltage, and the torque and armature current, are valid regardless the polarity of the armature voltage. Recalculating constants K_1 and K_2 will show you that their values are independent of the armature voltage polarity.

CONCLUSION

In this exercise, you have learned how to measure the armature resistance of a dc motor. You have seen that the speed of a separately-excited dc motor is proportional to the armature voltage applied to the motor. You saw that the torque produced by a dc motor is proportional to the armature current. You observed that the dc motor speed decreases with increasing armature current when the

The Separately-Excited DC Motor

armature voltage is fixed. You demonstrated that this speed decrease is caused by the increasing voltage drop across the armature resistor as the armature current increases.

If you have performed the additional experiments, you observed that the speed versus voltage and torque versus current relationships are not affected by the polarity of the armature voltage. You also observed that the direction of rotation is reversed when the polarity of the armature voltage is reversed.

REVIEW QUESTIONS

1. What kind of relationship exists between the speed and armature voltage of a separately-excited dc motor?
 - a. A linear relationship.
 - b. A parabolic relationship.
 - c. An exponential relationship.
 - d. The speed of the motor is independent of the applied voltage.

2. What kind of relationship exists between the torque and armature current of a separately-excited dc motor as long as the armature current does not exceed the nominal value?
 - a. A linear relationship.
 - b. A parabolic relationship.
 - c. An exponential relationship.
 - d. The motor torque is independent of the current.

3. Connecting a dc source to the armature of a dc motor that operates without field current and measuring the voltage that produces nominal current flow in the armature allows which parameter of the dc motor to be determined?
 - a. The nominal armature current.
 - b. The nominal armature voltage.
 - c. The armature resistance.
 - d. The resistance of the field winding.

4. Does the speed of a separately-excited dc motor increase or decrease when the armature current increases?
 - a. It increases.
 - b. It decreases.
 - c. It stays the same because speed is independent of motor current.
 - d. The speed will oscillate around the previous value.

The Separately-Excited DC Motor

5. The armature resistance R_A and constant K_1 of a dc motor are 0.5Ω and 5 r/min/V , respectively. A voltage of 200 V is applied to this motor. The no-load armature current is 2 A . At full load, the armature current increases to 50 A . What are the no-load and full-load speeds of the motor?
- a. $n_{\text{NO LOAD}} = 1005 \text{ r/min}$, $n_{\text{FULL LOAD}} = 880 \text{ r/min}$
 - b. $n_{\text{NO LOAD}} = 995 \text{ r/min}$, $n_{\text{FULL LOAD}} = 875 \text{ r/min}$
 - c. $n_{\text{NO LOAD}} = 1000 \text{ r/min}$, $n_{\text{FULL LOAD}} = 875 \text{ r/min}$
 - d. The speeds cannot be calculated without constant K_2 .

Separately-Excited, Series, Shunt, and Compound DC Motors

EXERCISE OBJECTIVE

When you have completed this exercise, you will be able to demonstrate how the field current affects the characteristics of a separately-excited dc motor using the DC Motor / Generator module. You will also be able to demonstrate the main operating characteristics of series, shunt, and compound motors.

DISCUSSION

Separately-Excited DC Motor

It is possible to change the characteristics of a separately-excited dc motor by changing the strength of the fixed magnetic field produced by the stator electromagnet. This can be carried out by changing the current that flows in the stator electromagnet. This current is usually referred to as the **field current** (I_F) because it is used to produce the fixed magnetic field in the dc motor. A rheostat connected in series with the electromagnet winding can be used to vary the field current.

Figure 2-15 illustrates how the speed versus armature voltage and torque versus armature current relationships of a separately-excited dc motor are affected when the field current is decreased below its nominal value. Constant K_1 becomes greater and constant K_2 becomes smaller. This means that the motor can rotate at higher speeds without exceeding the nominal armature voltage. However, the torque which the motor can develop, without exceeding the nominal armature current, is reduced.

It is also possible to set the field current of a separately-excited dc motor above its nominal value for short time intervals. The effect on the speed versus armature voltage and torque versus armature current relationships is reversed, i.e. constant K_1 becomes smaller and constant K_2 becomes higher. As a result, the motor can develop a higher torque during these time intervals but the speed at which the motor can rotate, without exceeding the nominal armature voltage, is reduced. Increasing the field current of a separately-excited dc motor when it is starting improves the motor torque, and thereby, provides faster acceleration.

Separately-Excited, Series, Shunt, and Compound DC Motors

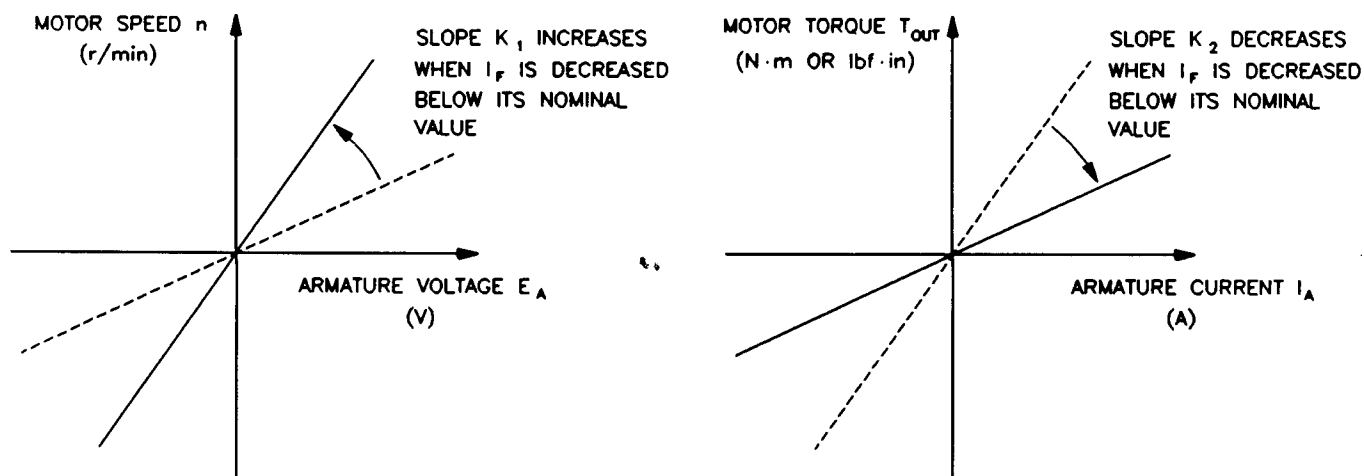

Figure 2-15. Decreasing Current I_f Below its Nominal Value Affects Constants K_1 and K_2 .

The strength of the fixed magnetic field in a dc motor can also be changed by changing the way the stator electromagnet is implemented. The stator electromagnet, or field electromagnet, can be a shunt winding connected directly to a dc voltage source, as in the separately-excited dc motor. A shunt winding can also be connected in parallel with the armature of the dc motor. The field electromagnet can also be a series winding, a coil consisting of a few loops of heavy-gage wire, connected in series with the armature. A combination of the shunt and series windings can also be used to implement the field electromagnet.

Various electromagnet implementations have been used so far to build several types of dc motors having different characteristics when powered by a fixed-voltage dc source. This was necessary at the time the first dc motors were in used, because variable-voltage dc sources were not still available. These dc motors, which are used less and less today, are briefly described in the following sections of this discussion.

Series Motor

The series motor is a motor in which the field electromagnet is a series winding connected in series with the armature as shown in Figure 2-16. The strength of the field electromagnet, therefore, varies as the armature current varies. As a result, K_1 and K_2 vary when the armature current varies. Figure 2-16 shows the speed versus torque characteristic of a series motor when the armature voltage is fixed. This characteristic shows that the speed decreases non linearly as the torque increases, i.e. as the armature current increases.

Separately-Excited, Series, Shunt, and Compound DC Motors

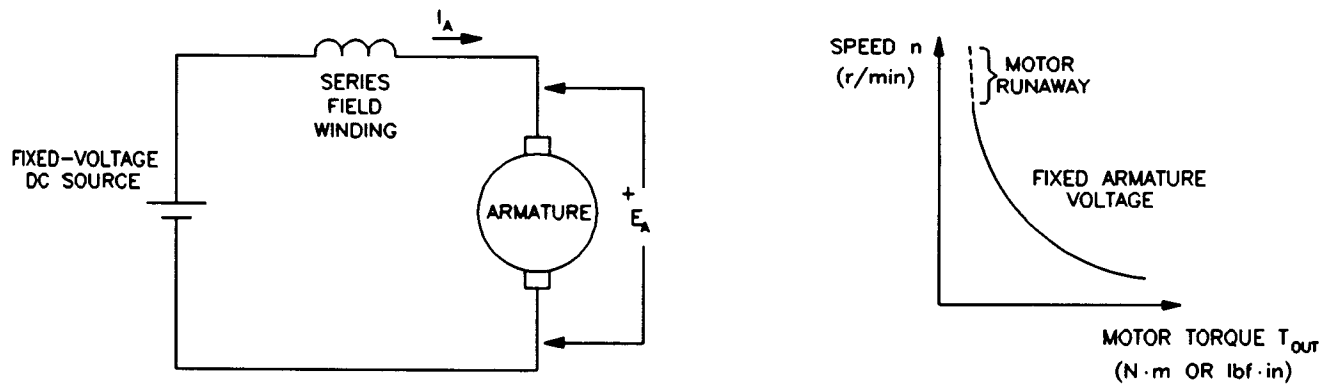

Figure 2-16. Series Motor and its Speed Versus Torque Characteristic.

The series motor provides a strong starting torque and a wide range of operating speeds when it is supplied by a fixed-voltage dc source. However, the speed, torque, and armature current depend on the mechanical load applied to the motor. Also, the series motor has non-linear operating characteristics as suggested by the speed versus torque relationship in Figure 2-16. As a result, it is difficult to operate a series motor at a constant speed when the mechanical load fluctuates. Furthermore, the armature current must be limited to prevent damages to the motor when it is starting (when power is applied to the motor). Finally, a series motor must never run with no mechanical load because the speed increases to a very-high value which can damage the motor (motor runaway).

Today, series motors can operate with fixed-voltage power sources, for example, automobile starting motors; or with variable-voltage power sources, for example, traction systems.

Shunt Motor

The shunt motor is a motor in which the field electromagnet is a shunt winding connected in parallel with the armature, both being connected to the same dc voltage source as shown in Figure 2-17. For a fixed armature voltage, constants K_1 and K_2 are fixed, and the speed versus torque characteristic is very similar to that obtained with a separately-excited dc motor powered by a fixed-voltage dc source, as shown in Figure 2-17. As in a separately-excited dc motor, the characteristics (K_1 and K_2) of a shunt motor can be changed by varying the field current with a rheostat. However, it is difficult to change the speed of a shunt motor by changing the armature voltage, because this changes the field current, and thereby, the motor characteristics, in a way that opposes speed change.

Separately-Excited, Series, Shunt, and Compound DC Motors

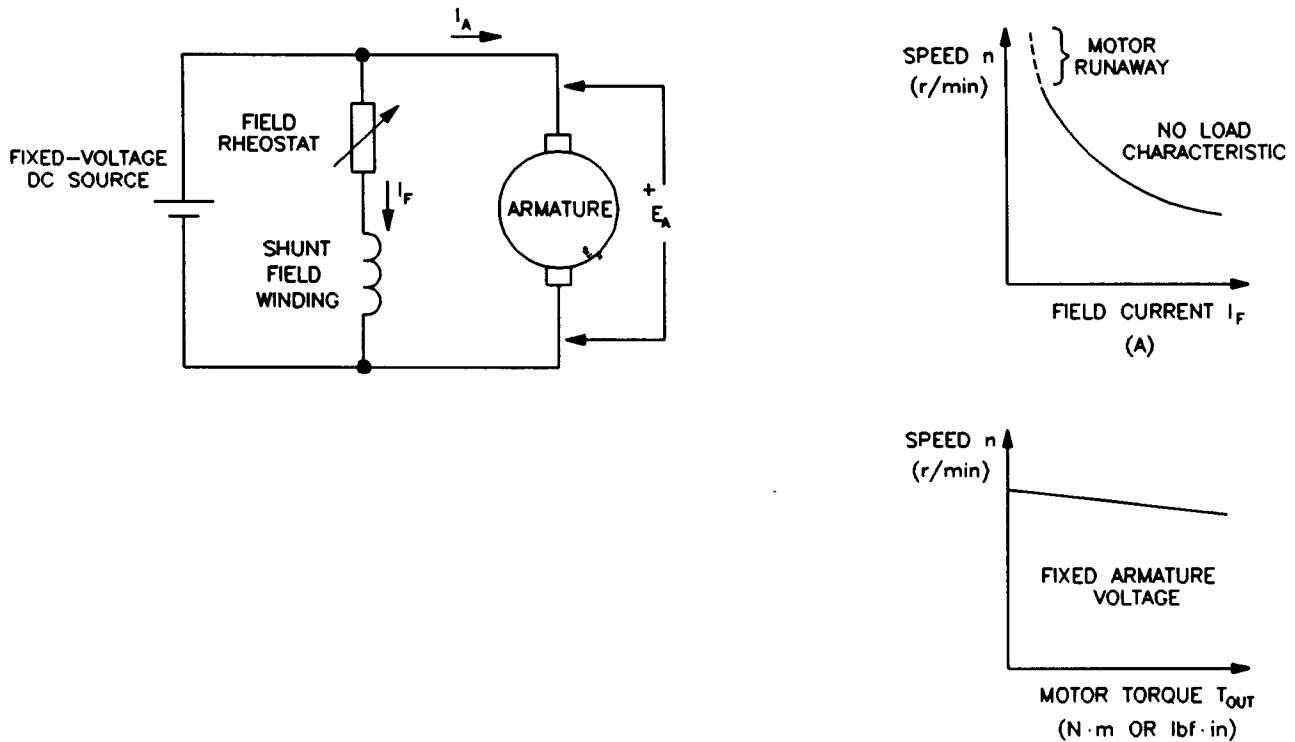

Figure 2-17. Shunt Motor and its Characteristics.

The main advantage of a shunt motor is the fact that only a single fixed-voltage dc source is required to supply power to both the armature and the shunt winding. Also, speed varies little as the mechanical load varies. However, a shunt motor has a limited speed range because speed cannot be easily varied by varying the armature voltage. Furthermore, the armature current must be limited to prevent damages to the motor when it is starting (when power is applied to the motor). Finally, when the shunt winding opens accidentally, the field current I_F becomes zero, the motor speed increases rapidly, and motor runaway occurs as suggested by the speed versus field current characteristic shown in Figure 2-17.

Compound Motor

It is possible to combine shunt and series windings to obtain a particular speed versus torque characteristic. For example, to obtain the characteristic of decreasing speed when the motor torque increases, a series winding can be connected in series with the armature so that the magnetic flux it produces adds with the magnetic flux produced by a shunt winding. As a result, the magnetic flux increases automatically with increasing armature current. This type of dc motor is referred to as a cumulative compound motor because the magnetic fluxes produced by the series and shunt windings add together. Shunt and series windings can also be connected so that the magnetic fluxes subtract from each other. This connection produces a differential-compound motor, which is rarely used because the motor becomes unstable when the armature current increases.

Separately-Excited, Series, Shunt, and Compound DC Motors

Figure 2-18 shows a compound motor and its speed versus torque characteristic (cumulative compound).

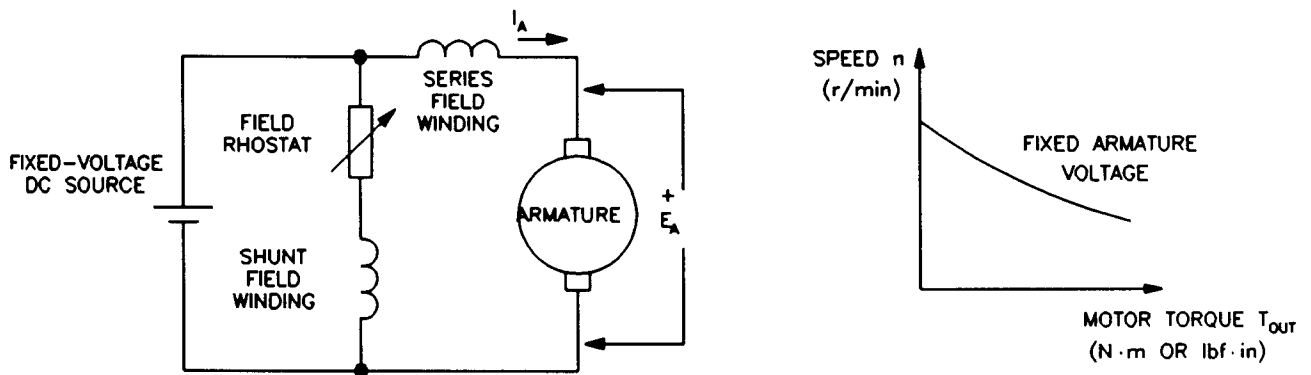

Figure 2-18. Compound Motor and its Speed Versus Torque Characteristic.

Figure 2-19 is a graph that shows the speed versus torque characteristics of the various types of dc motors discussed so far. As can be seen, the separately-excited dc motor and the shunt motor have very similar characteristics. The main feature of these characteristics is that the motor speed varies little and linearly as the torque varies. On the other hand, the series motor characteristic is non linear and shows that the motor speed varies a lot (wide range of operating speed) as the torque varies. Finally, the characteristic of a cumulative compound motor is a compromise of the series and shunt motor characteristics. It provides the compound motor with a fairly wide range of operating speed, but the speed does not vary linearly as the torque varies.

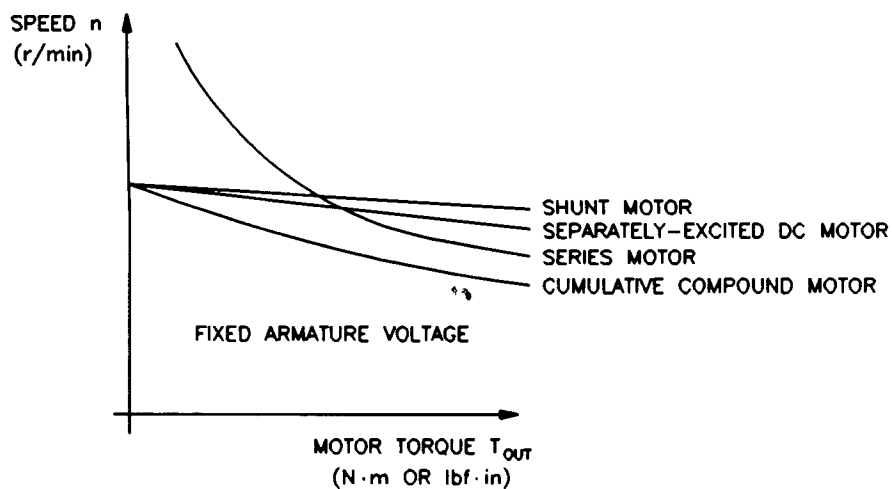

Figure 2-19. Speed Versus Torque Characteristics of Various DC Motors.

Separately-Excited, Series, Shunt, and Compound DC Motors

Procedure Summary

In the first part of the exercise, you will set up the equipment in the Workstation, connect the equipment as shown in Figure 2-20, and make the appropriate settings on the Prime Mover / Dynamometer.

In the second part of the exercise, you will set the field current of the separately-excited dc motor to a lower value than in the previous exercise (below the nominal value). You will measure data and plot a graph of the motor speed n versus the armature voltage E_A . You will calculate constant K_1 . You will compare constant K_1 and the graph with those obtained in the previous exercise to determine how decreasing the field current affects these characteristics.

In the third part of the exercise, you will measure data and plot a graph of the motor torque T versus the armature current I_A . You will calculate constant K_2 . You will compare constant K_2 and the graph with those obtained in the previous exercise to determine how decreasing the field current affects these characteristics.

In the fourth part of the exercise, you will connect the DC Motor / Generator as a series motor (see setup in Figure 2-21). You will measure data and plot a graph of the motor speed n versus the motor torque T . You will compare the speed versus torque characteristic of the series motor to that of the separately-excited dc motor obtained in the previous exercise.

EQUIPMENT REQUIRED

Refer to the Equipment Utilization Chart in Appendix C to obtain the list of equipment required for this exercise.

PROCEDURE

CAUTION!

High voltages are present in this laboratory exercise! Do not make or modify any banana jack connections with the power on unless otherwise specified!

Setting up the Equipment

1. Install the Power Supply, Prime Mover / Dynamometer, DC Motor / Generator, and Data Acquisition Interface modules in the EMS workstation.

Separately-Excited, Series, Shunt, and Compound DC Motors

Note: If you are performing the exercise using the EMS system, ensure that the brushes of the DC Motor/Generator are adjusted to the neutral point. To do so, connect an ac power source (terminals 4 and N of the Power Supply) to the armature of the DC Motor/Generator (terminals 1 and 2) through CURRENT INPUT I1 of the Data Acquisition Interface module. Connect the shunt winding of the DC Motor/Generator (terminals 5 and 6) to VOLTAGE INPUT E1 of the Data Acquisition Interface module. Start the Metering application and open setup configuration file ACMOTOR1.CFG. Turn on the Power Supply and set the voltage control knob so that an ac current (indicated by meter I1) equal to half the nominal value of the armature current flows in the armature of the DC Motor/Generator. Adjust the brushes adjustment lever on the DC Motor/Generator so that the voltage across the shunt winding (indicated by meter E1) is minimum. Turn off the Power Supply, exit the Metering application, and disconnect all leads and cable.

Mechanically couple the Prime Mover / Dynamometer to the DC Motor / Generator using a timing belt.

- 2. On the Power Supply, make sure the main power switch is set to the O (off) position, and the voltage control knob is turned fully counterclockwise. Ensure the Power Supply is connected to a three-phase power source.

- 3. Ensure that the flat cable from the computer is connected to the DAI module.

Connect the LOW POWER INPUTs of the DAI and Prime Mover / Dynamometer modules to the 24 V - AC output of the Power Supply.

On the Power Supply, set the 24 V - AC power switch to the I (on) position.

- 4. Start the Metering application.

In the Metering application, open setup configuration file DCMOTOR1.CFG then select custom view 1.

- 5. Set up the separately-excited dc motor circuit shown in Figure 2-20. Note that this setup is the same as that used in the previous exercise.

Note: If you are performing the exercise with a line voltage of 220 V, use the Resistive Load module to connect a 880- Ω resistor in series with the rheostat of the DC Motor/Generator. If you are performing the exercise with a line voltage of 240 V, connect a 960- Ω resistor in series with the rheostat.

Separately-Excited, Series, Shunt, and Compound DC Motors

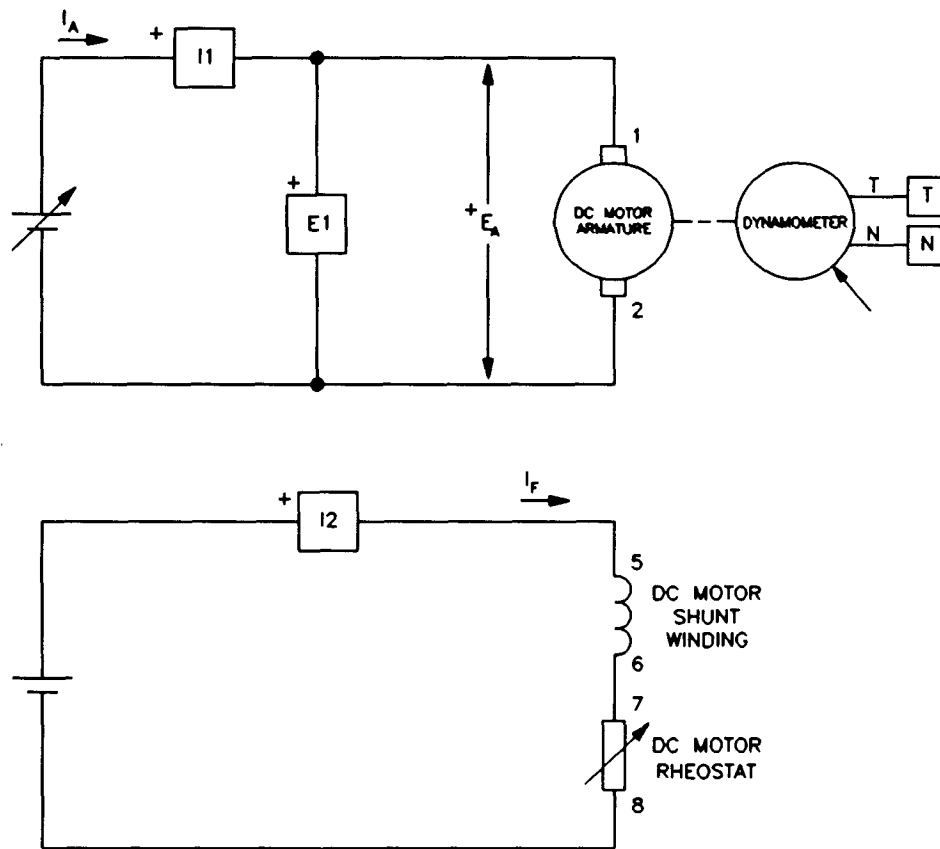

Figure 2-20. Separately-Excited DC Motor Coupled to a Dynamometer.

- 6. Set the Prime Mover / Dynamometer controls as follows:

| | | |
|--------------------------|-------|------------------|
| MODE switch | | DYN. |
| LOAD CONTROL MODE switch | | MAN. |
| LOAD CONTROL knob | | MIN. (fully CCW) |
| DISPLAY switch | | SPEED (N) |

Note: If you are performing the exercise using LVSIM™-EMS, you can zoom in the Prime Mover / Dynamometer module before setting the controls in order to see additional front panel markings related to these controls.

Speed Versus Armature Voltage Characteristic of a Separately-Excited DC Motor

- 7. Turn on the Power Supply.

On the DC Motor / Generator, set the FIELD RHEOSTAT so that the field current I_f indicated by meter I2 in the Metering application is equal to the value given in the following table:

Separately-Excited, Series, Shunt, and Compound DC Motors

| LINE VOLTAGE | FIELD CURRENT I_f |
|-----------------|------------------------|
| V ac | mA |
| 120 | 200 |
| 220 | 125 |
| 240 | 140 |

Table 2-3. Field Current of the Separately-Excited DC Motor.

8. In the Metering application, select the torque correction function for meter T. Meter T now indicates the dc motor output torque. Record the dc motor speed n , armature voltage E_A , armature current I_A , field current I_f , and output torque T (indicated by meters N, E1, I1, I2, and T respectively) in the Data Table.

On the Power Supply, set the voltage control knob to 10%, 20%, 30% etc. up to 100% in order to increase the armature voltage E_A by steps. For each voltage setting, wait until the motor speed stabilizes, and then record the data in the Data Table.

Note: If you are performing the exercise using LVSIM™-EMS, click the button located beside the Power Supply display until the % inscription appears in this button. This will cause the Power Supply display to indicate the position of the voltage control knob in percentage values.

9. When all data has been recorded, turn the voltage control knob fully counterclockwise and turn off the Power Supply.

In the Data Table window, confirm that the data has been stored, edit the data table so as to keep only the values of the dc motor speed n , armature voltage E_A , armature current I_A , field current I_f , and output torque T (data in columns N, E1, I1, I2, and T, respectively), entitle the data table as DT221, and print the data table.

Note: Refer to Appendix E of this manual to know how to edit, entitle, and print a data table.

10. In the Graph window, make the appropriate settings to obtain a graph of the dc motor speed n (obtained from meter N) as a function of the armature voltage E_A (obtained from meter E1). Entitle the graph as G221, name the x-axis as Armature Voltage, name the y-axis as DC Motor Speed, and print the graph.

Note: Refer to Appendix E of this manual to know how to use the Graph window of the Metering application to obtain a graph, entitle a graph, name the axes of a graph, and print a graph.

Separately-Excited, Series, Shunt, and Compound DC Motors

Sep
and

11. Use the two end points to calculate the slope K_f of the relationship obtained in graph G221. The values of these points are indicated in data table DT221.

$$K_f = \frac{n_2 - n_1}{E_2 - E_1} = \frac{\quad - \quad}{\quad - \quad} = \frac{\quad}{\quad} \frac{\text{r/min}}{\text{V}}$$

Compare graph G221 and constant K_f obtained in this exercise with graph G211 and constant K_f obtained in the previous exercise. Describe how does decreasing the field current I_f affect the speed versus voltage characteristic and constant K_f of a separately-excited dc motor.

In the Data Table window, clear the recorded data.

Torque Versus Armature Current Characteristic of a Separately-Excited DC Motor

12. Turn on the Power Supply.

On the DC Motor / Generator, slightly readjust the FIELD RHEOSTAT so that the field current I_f indicated by meter I2 in the Metering application still equals the value given in Table 2-3 (if necessary).

On the Power Supply, set the voltage control knob so that the dc motor speed is 1500 r/min. Note the value of the armature voltage E_A in the following blank space.

$$E_A = \quad \text{V} \quad (n = 1500 \text{ r/min})$$

13. In the Metering application, record the dc motor output torque T , armature voltage E_A , armature current I_A , field current I_f , and speed n (indicated by meters T, E1, I1, I2, and N, respectively) in the Data Table.

On the Prime Mover / Dynamometer, set the DISPLAY switch to the TORQUE (T) position then adjust the LOAD CONTROL knob so that the torque indicated on the module display increases by 0.2 N·m (2.0 lbf·in) increments up to 1.2 N·m (12.0 lbf·in). For each torque setting, readjust the voltage control knob of the Power Supply so that the armature voltage E_A remains equal to the value recorded in the previous step, then record the data in the Data Table.

Note: The armature current may exceed the rated value while performing this manipulation. It is, therefore, suggested to complete the manipulation within a time interval of 5 minutes or less.

Separately-Excited, Series, Shunt, and Compound DC Motors

- 14. When all data has been recorded, set the LOAD CONTROL knob on the Prime Mover / Dynamometer to the MIN. position (fully CCW), turn the voltage control knob fully counterclockwise, and turn off the Power Supply.

In the Data Table window, confirm that the data has been stored, edit the table so as to keep only the values of the dc motor torque T , armature voltage E_A , armature current I_A , field current I_F , and speed n (data in columns T, E1, I1, I2, and N, respectively), entitle the data table as DT222, and print the data table.

- 15. In the Graph window, make the appropriate settings to obtain a graph of the dc motor torque (obtained from meter T) as a function of the armature current I_A (obtained from meter I1). Entitle the graph as G222, name the x-axis as Armature Current, name the y-axis as DC Motor Torque, and print the graph.

Note: The torque versus current relationship is no longer linear when the armature current exceeds the nominal value because of a phenomenon called armature reaction. This phenomenon is described in the next unit of this manual.

- 16. Use the two end points of the linear portion of the relationship obtained in graph G222 to calculate the slope K_2 . The values of these points are indicated in data table DT222.

$$K_2 = \frac{T_2 - T_1}{I_2 - I_1} = \frac{\text{N}\cdot\text{m (lb}\cdot\text{ft)}}{\text{A}}$$

Compare graph G222 and constant K_2 obtained in this exercise with graph G212 and constant K_2 obtained in the previous exercise. Describe how does decreasing the field current I_F affect the torque versus current characteristic and constant K_2 of a separately-excited dc motor.

In the Data Table window, clear the recorded data.

Speed Versus Torque Characteristic of a Series Motor

- 17. Modify the connections so as to obtain the series motor circuit shown in Figure 2-21.

Separately-Excited, Series, Shunt, and Compound DC Motors

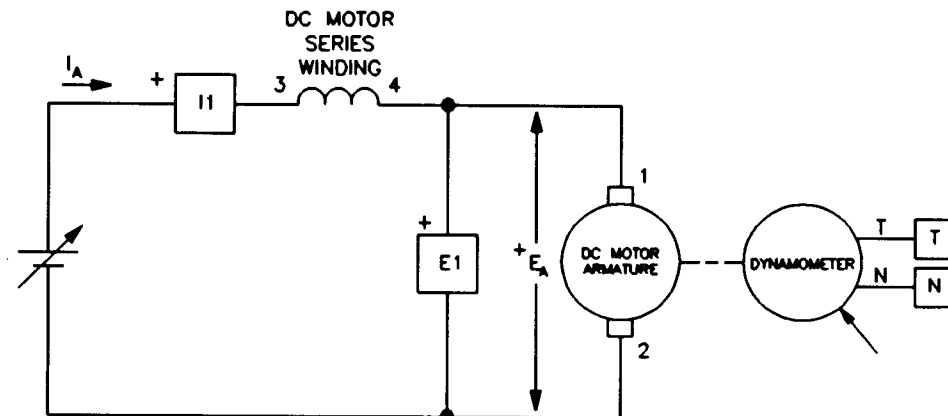

Figure 2-21. Series Motor Coupled to a Dynamometer.

- 18. Turn on the Power Supply and set the voltage control knob so that the armature voltage E_A indicated by meter E1 is equal to the value recorded in step 14 of the previous exercise. The series motor should start to rotate.
- 19. In the Metering application, make sure the torque correction function of meter T is selected. Record the motor speed n , output torque T , armature voltage E_A , and armature current I_A (indicated by meters n , T, E1, and I1, respectively) in the Data Table.

On the Prime Mover / Dynamometer, adjust the LOAD CONTROL knob so that the torque indicated on the module display increases by 0.2 N·m (2.0 lbf·in) increments up to 2.0 N·m (18.0 lbf·in). For each torque setting, readjust the voltage control knob of the Power Supply so that the armature voltage E_A remains equal to the value set in the previous step, wait until the motor speed stabilizes, and then record the data in the Data Table.

Note: The armature current may exceed the rated value while performing this manipulation. It is, therefore, suggested to complete the manipulation within a time interval of 5 minutes or less.

- 20. When all data has been recorded, set the LOAD CONTROL knob on the Prime Mover / Dynamometer to the MIN. position (fully CCW), turn the voltage control knob fully counterclockwise, and turn off the Power Supply.

In the Data Table window, confirm that the data has been stored, edit the table so as to keep only the values of the series motor speed n , torque T , armature voltage E_A , and armature current I_A (data in columns N, T, E1, and I1, respectively), entitle the data table as DT223, and print the data table.

Separately-Excited, Series, Shunt, and Compound DC Motors

- 21. In the Graph window, make the appropriate settings to obtain a graph of the series motor speed (obtained from meter N) as a function of the series motor torque (obtained from meter T). Entitle the graph as G223, name the x-axis as Series Motor Torque, name the y-axis as Series Motor Speed, and print the graph.

Briefly describe how the speed varies as the mechanical load applied to the series motor increases, i.e. as the motor torque increases.

Compare the speed versus torque characteristic of the series motor (graph G223) to that of the separately-excited dc motor (graph G212-2 obtained in the previous exercise).

- 22. Set the 24 V - AC power switch to the O (off) position, and remove all leads and cables.

ADDITIONAL EXPERIMENTS

Speed Versus Torque Characteristic of a Shunt Motor

You can obtain the speed versus torque characteristic of a shunt motor and compare it to those obtained for the separately-excited dc motor and series motor. To do so, make sure the Power Supply is turned off and set up the shunt motor circuit shown in Figure 2-22. Make sure the LOAD CONTROL knob on the Prime Mover / Dynamometer is set to the MIN. position (fully CCW). Turn on the Power Supply, set the armature voltage E_a to the value recorded in step 14 of the previous exercise. Set the FIELD RHEOSTAT on the DC Motor/Generator so that the field current I_f is equal to the value indicated in Table 2-1. Clear the data recorded in the data table. Refer to steps 19 to 21 of this exercise to record the necessary data and obtain the graph. Entitle the data table and graph as DT224 and G224, respectively. Compare the speed versus torque characteristic of the shunt motor (graph G224) to those of the separately-excited dc motor (graph G212-2 obtained in the previous exercise) and series motor (graph G223).

Separately-Excited, Series, Shunt, and Compound DC Motors

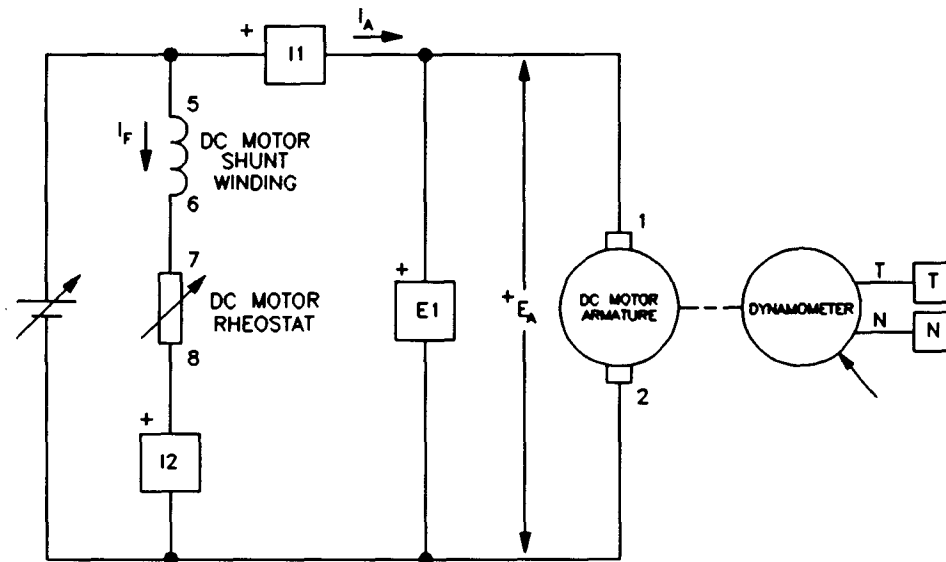

Figure 2-22. Shunt Motor Circuit.

Speed Versus Torque Characteristic of a Cumulative Compound Motor

You can obtain the speed versus torque characteristic of a cumulative compound motor and compare it to those obtained for the other dc motors. To do so, make sure the Power Supply is turned off and set up the cumulative compound motor circuit shown in Figure 2-23. Make sure the LOAD CONTROL knob on the Prime Mover / Dynamometer is set to the MIN. position (fully CCW). Turn on the Power Supply, set the armature voltage E_A to the value recorded in step 14 of the previous exercise. Set the FIELD RHEOSTAT on the DC Motor/Generator so that the current in the shunt winding is equal to the value indicated in Table 2-1. Clear the data recorded in the data table. Refer to steps 19 to 21 of this exercise to record the necessary data and obtain the graph. Entitle the data table and graph as DT225 and G225, respectively. Compare the speed versus torque characteristic of the cumulative compound motor (graph G225) to those of the other dc motors (graphs G212-2, G223, and G224).

Separately-Excited, Series, Shunt, and Compound DC Motors

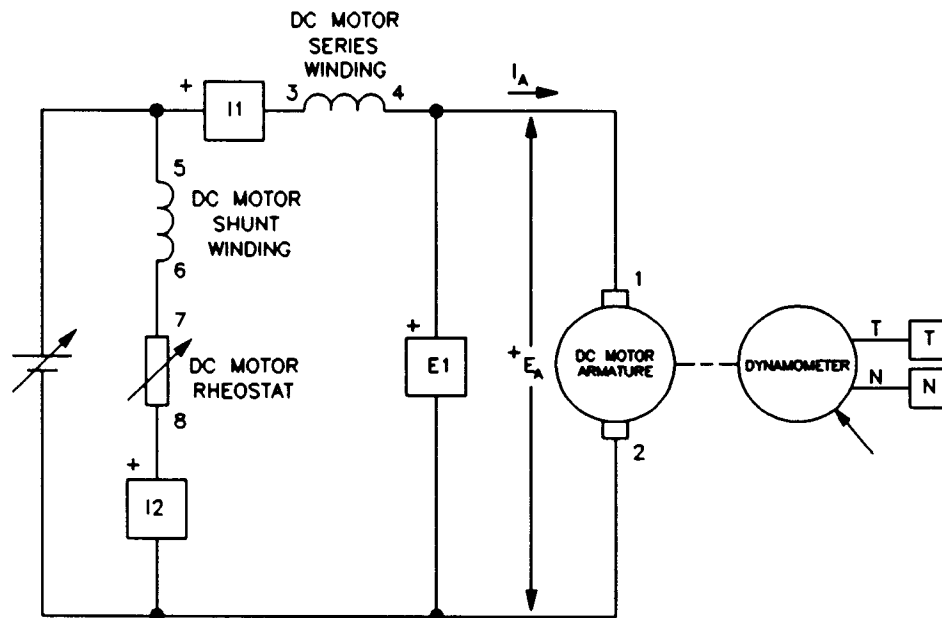

Figure 2-23. Cumulative-Compound Motor Circuit.

CONCLUSION

In this exercise, you observed that decreasing the field current of a separately-excited dc motor below its nominal value increases constant K_1 , but decreases constant K_2 . You saw that this allows the motor to rotate at higher speeds without exceeding the nominal armature voltage but reduces the torque which the motor can develop without exceeding the nominal armature current. You also saw that it is possible to increase the field current above its nominal value for short time intervals to improve the starting torque. You plotted a graph of the speed versus torque characteristic of a series motor and compared it to that obtained in the previous exercise with a separately-excited dc motor. You observed that the speed of a series motor decreases more rapidly than that of the separately-excited dc motor as the torque increases. Furthermore, you observed that the speed versus torque characteristic of the separately-excited dc motor is linear whereas that of the series motor is non linear.

If you have performed the additional experiments, you plotted graphs of the speed versus torque characteristic for a shunt motor and a cumulative compound motor. You compared these characteristics to those obtained with the separately-excited dc motor and the series motor. You found that the characteristic of a shunt motor is very similar to that of a separately-excited dc motor. You saw that the characteristic of a cumulative compound motor is a compromise of the characteristics of the separately-excited dc motor and series motor.

Separately-Excited, Series, Shunt, and Compound DC Motors

REVIEW QUESTIONS

1. What effect does decreasing the field current below its nominal value have on the speed versus voltage characteristic of a separately-excited dc motor?
 - a. Constant K_1 increases.
 - b. Constant K_2 increases.
 - c. Constant K_1 decreases.
 - d. Constant K_2 decreases.

2. What effect does decreasing the field current below its nominal value have on the torque-current characteristic of a separately-excited dc motor?
 - a. Constant K_1 increases.
 - b. Constant K_2 increases.
 - c. Constant K_1 decreases.
 - d. Constant K_2 decreases.

3. What is the advantage of increasing the field current above its nominal value for a short time interval when starting a separately-excited dc motor?
 - a. This prevent damages to the motor.
 - b. This allows the motor to reach a higher speed.
 - c. This increases the armature voltage.
 - d. This increases the starting torque.

4. Does the speed of a shunt motor increase or decrease when the armature current increases?
 - a. It increases.
 - b. It decreases.
 - c. It oscillates around the previous value.
 - d. It does not change because speed is independent of the armature current.

5. What is the advantage of decreasing the field current of a separately-excited dc motor below its nominal value?
 - a. This allows the motor to develop a higher torque without exceeding the nominal armature voltage.
 - b. This allows the motor to develop a higher torque without exceeding the nominal armature current.
 - c. This allows the motor to rotate at a higher speed without exceeding the nominal armature voltage.
 - d. This has no advantage.

Exercise 2-3

Separately-Excited, Shunt, and Compound DC Generators

EXERCISE OBJECTIVE

When you have completed this exercise, you will be able to demonstrate the main operating characteristics of separately-excited, shunt, and compound generators using the DC Motor/Generator module.

DISCUSSION

Although dc generators are rarely used today, it is important to know their operation because this helps understanding how a separately-excited dc motor can be used as an electric brake in modern dc motor drives.

You saw earlier in this unit that a dc motor can be considered as a linear voltage-to-speed converter. This linear conversion process is reversible, meaning that when a fixed speed is imposed on the motor by an external driving force, the motor produces an output voltage E_o , and thus, operates as a linear speed-to-voltage converter, i.e. a dc generator. Figure 2-24 illustrates a dc motor operating as a dc generator.

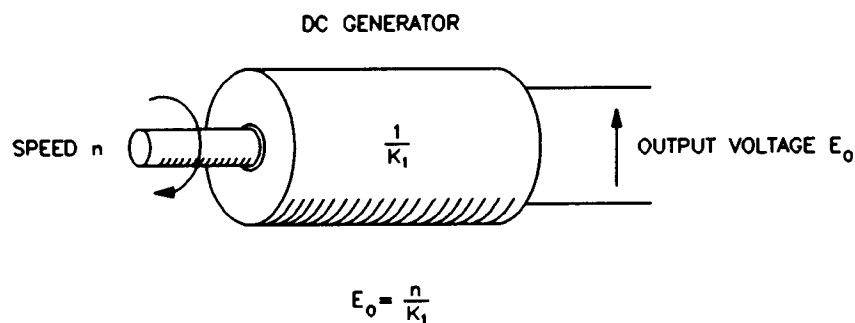

Figure 2-24. DC Motor as a Speed-to-Voltage Converter (DC Generator).

The linear relationship that exists between torque and current for the dc motor is also reversible and applies to the dc generator, i.e. a torque must be applied to the generator's shaft to obtain a certain output current. Figure 2-25 illustrates a dc motor operating as a linear torque-to-current converter, i.e. a dc generator.

Separately-Excited, Shunt, and Compound DC Generators

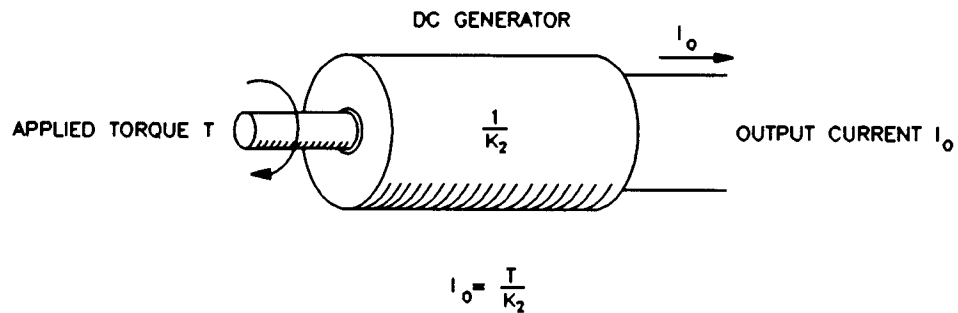
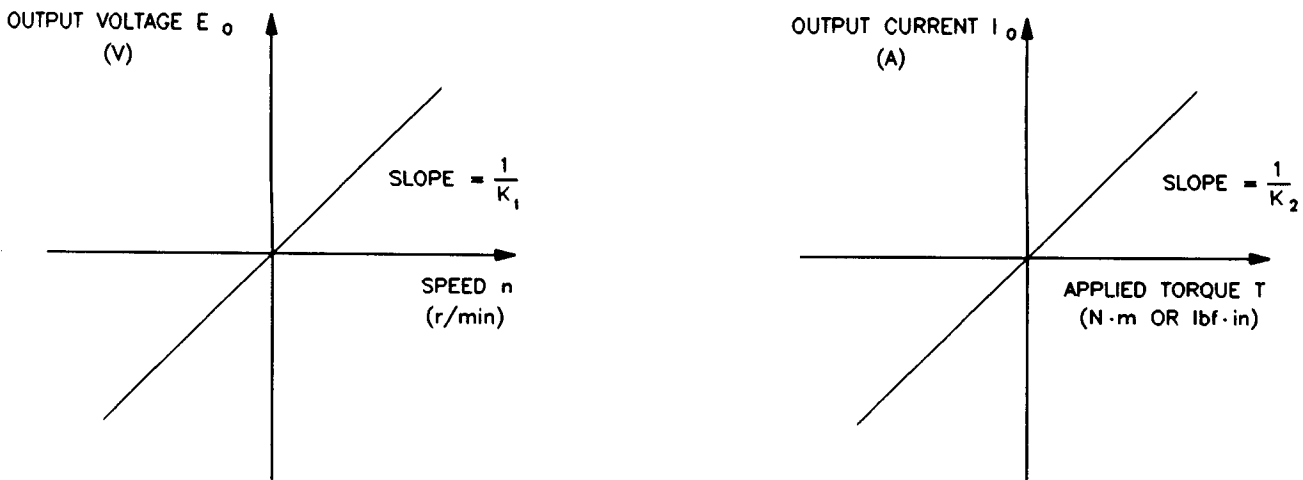

Figure 2-25. DC Motor as a Torque-to-Current Converter (DC Generator).

Figure 2-26 (a) shows the output voltage versus speed relationship of a separately-excited dc generator. Figure 2-26 (b) shows the output current versus applied torque relationship of a separately-excited dc generator. Notice that the slopes of these linear relationships are equal to the reciprocal of constants K_1 and K_2 .



a) OUTPUT VOLTAGE VERSUS SPEED

b) OUTPUT CURRENT VERSUS APPLIED TORQUE

Figure 2-26. Input-Output Relationships of a Separately-Excited DC Generator.

In a manner similar to that for a separately-excited dc motor, the field current I_f of a separately-excited dc generator can be varied to change the strength of the field electromagnet, and thereby, the relative values of constant K_1 and K_2 . When the field current is decreased, constant K_1 increases and constant K_2 decreases, as for a separately-excited dc motor. As a result, the slope of the output voltage versus speed relationship decreases whereas the slope of the output current versus torque relationship increases. Conversely, when the field current is increased, constant K_1 decreases and constant K_2 increases, and thereby, the slope of the output voltage versus speed relationship increases whereas the slope

Separately-Excited, Shunt, and Compound DC Generators

of the output current versus torque relationship decreases. Therefore, the output voltage E_o of a generator operating at a fixed speed can be varied by varying the field current I_f . This produces the equivalent of a dc source whose output voltage can be controlled by the field current I_f . Figure 2-27 shows the variation of output voltage E_o for a separately-excited dc generator operating at a fixed speed, when the field current I_f is varied over the range from zero to its nominal value.

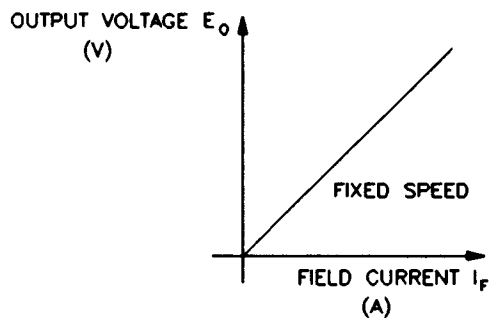

Figure 2-27. E_o Versus I_f for a Separately-Excited DC Generator Operating at a Fixed Speed.

The simplified equivalent electric circuit of a separately-excited dc generator is shown in Figure 2-28. It is the same as that for the dc motor, except that the direction of current flow is reversed and voltage E_{CEMF} becomes E_{EMF} , which is the voltage induced across the armature winding as it rotates in the magnetic flux produced by the stator electromagnet. When no load is connected to the dc generator output, the output current I_o is zero and the output voltage E_o equals E_{EMF} .

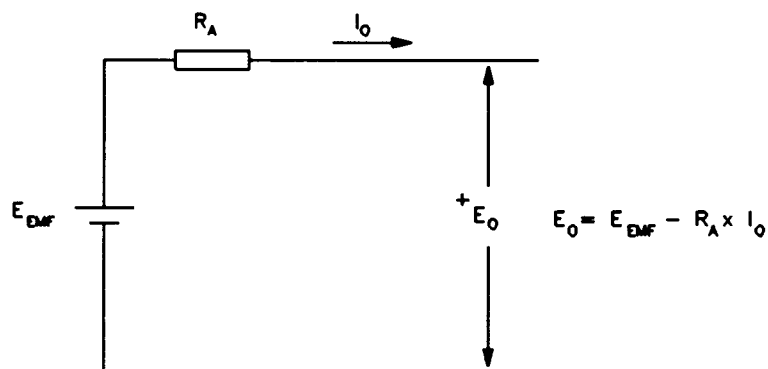

Figure 2-28. Simplified Equivalent Circuit of a DC Generator.

In the first exercise of this unit, you observed that when a fixed armature voltage E_A is applied to a separately-excited dc motor, its speed decreases as the armature current I_A increases. You found that this decrease in speed is due to the armature resistance R_A . Similarly, when the same motor operates as a generator and at a fixed speed, the armature resistance causes the output voltage E_o to decrease with increasing output current as shown in Figure 2-29. The output voltage E_o can be calculated using the following equation:

Separately-Excited, Shunt, and Compound DC Generators

$$E_o = E_{EMF} - R_A \times I_o$$

where E_o is the dc generator output voltage,
 E_{EMF} is the voltage induced across the armature winding,
 R_A is the armature resistance,
 I_o is the dc generator output current.

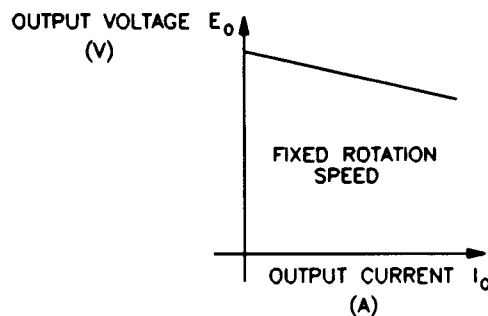

Figure 2-29. Voltage Versus Current Characteristic of a Separately-Excited DC Generator (Fixed Speed).

The separately-excited dc generator provides flexible use because its characteristics can be changed by changing the field current. However, a separate dc power source is needed to excite the field electromagnet. This was a disadvantage at the time the first dc generators were in use because dc sources were not commonly available at the time. Therefore, dc generators that operate without a dc power source were designed. These are referred to as self-excited dc generators.

In a self-excited dc generator, the field electromagnet is a shunt winding connected across the generator output (shunt generator) or a combination of a shunt winding connected across the generator output and a series winding connected in series with the generator output (compound generator). The generator output voltage and/or current excite(s) the field electromagnet. The way the field electromagnet is implemented (shunt or compound) determines many of the generator's characteristics.

Self-excitation is possible because of the residual magnetism in the stator pole pieces. As the armature rotates, a small voltage is induced across its winding and a small current flows in the shunt field winding. If this small field current is flowing in the proper direction, the residual magnetism is reinforced which further increases the armature voltage. Thus, a rapid voltage build-up occurs. If the field current flows in the wrong direction, the residual magnetism is reduced and voltage build-up cannot occur. In this case, reversing the connections of the shunt field winding corrects the situation.

In a self-excited dc generator, the output voltage after build-up could be of the opposite polarity to that required. This can be corrected by stopping the generator and setting the polarity of the residual magnetism. To set the residual magnetism, a dc source is connected to the shunt field winding to force nominal current flow in the proper direction. Interrupting the current suddenly sets the

Separately-Excited, Shunt, and Compound DC Generators

polarity of the magnetic poles in the shunt field winding. When the generator is started once again, voltage build-up at the proper polarity occurs.

Figure 2-30 is a graph that shows the voltage versus current characteristics of various types of dc generators. As can be seen, the separately-excited dc generator and the shunt generator have very similar characteristics. The difference is that the output voltage of the shunt generator decreases a little more than that of the separately-excited dc generator as the output current increases. In both cases, the output voltage decreases because the voltage drop across the armature resistor increases as the output current increases. In the shunt generator, the voltage across the shunt field winding, and thereby, the field current, decreases as the output voltage decreases. This causes the output voltage to decrease a little more.

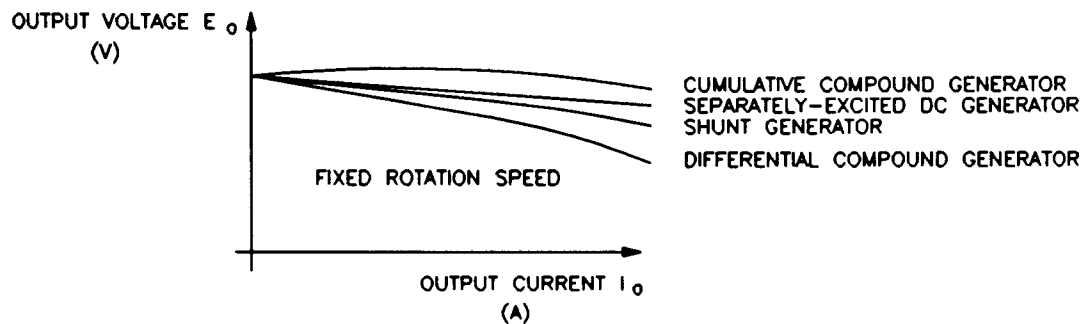

Figure 2-30. Voltage Versus Current Characteristics of Various DC Generators.

It is possible to compensate the variation in output voltage by automatically changing the magnetic flux produced by the field electromagnet as the output current varies. The shunt and series field windings of a compound generator can be connected so that the magnetic flux increases when the output current increases. Thus, the output voltage remains fairly constant and changes very little as the output current increases as shown in Figure 2-30. This type of connection results in a cumulative compound generator because the magnetic fluxes created by the two field windings add together in a cumulative manner. For other applications where the output voltage must decrease rapidly when the output current increases, the shunt and series windings can be connected so the magnetic fluxes subtract from each other, resulting in a differential compound generator.

Procedure Summary

In the first part of the exercise, you will set up the equipment in the Workstation, connect the equipment as shown in Figure 2-31, and make the appropriate settings on the Prime Mover / Dynamometer.

In the second part of the exercise, you will set the field current of the separately-excited dc generator to the same value as that used in Exercise 2-1. You will measure data and plot a graph of the output voltage E_o versus speed n when no electrical load is connected to the generator output. You will calculate the slope

Separately-Excited, Shunt, and Compound DC Generators

of the voltage versus speed relationship and compare it to constant K_1 determined in Exercise 2-1 when the DC Motor/Generator was operating as a separately-excited dc motor.

In the third part of the exercise, you will connect an electrical load to the generator output (setup shown in Figure 2-32), measure data, and plot a graph of the output current I_o versus the applied torque T when the separately-excited dc generator rotates at a fixed speed. You will calculate the slope of the current versus torque relationship and compare it to constant K_2 determined in Exercise 2-1 when the DC Motor/Generator was operating as a separately-excited dc motor.

In the fourth part of the exercise, you will vary the field current I_f of the separately-excited dc generator and observe how the output voltage is affected.

In the fifth part of the exercise, you will use the data obtained in the third part of the exercise to plot a graph of the output voltage versus output current when the separately-excited dc generator operates at a fixed speed.

EQUIPMENT REQUIRED

Refer to the Equipment Utilization Chart in Appendix C to obtain the list of equipment required for this exercise.

PROCEDURE

CAUTION!

High voltages are present in this laboratory exercise! Do not make or modify any banana jack connections with the power on unless otherwise specified!

Setting up the Equipment

1. Install the Power Supply, Prime Mover / Dynamometer, DC Motor / Generator, Resistive Load, and Data Acquisition Interface modules in the EMS workstation.

Separately-Excited, Shunt, and Compound DC Generators

Note: If you are performing the exercise using the EMS system, ensure that the brushes of the DC Motor/Generator are adjusted to the neutral point. To do so, connect an ac power source (terminals 4 and N of the Power Supply) to the armature of the DC Motor/Generator (terminals 1 and 2) through CURRENT INPUT I1 of the Data Acquisition Interface module. Connect the shunt winding of the DC Motor/Generator (terminals 5 and 6) to VOLTAGE INPUT E1 of the Data Acquisition Interface module. Start the Metering application and open setup configuration file ACMOTOR1.CFG. Turn on the Power Supply and set the voltage control knob so that an ac current (indicated by meter I1) equal to half the nominal value of the armature current flows in the armature of the DC Motor/Generator. Adjust the brushes adjustment lever on the DC Motor/Generator so that the voltage across the shunt winding (indicated by meter E1) is minimum. Turn off the Power Supply, exit the Metering application, and disconnect all leads and cable.

Mechanically couple the Prime Mover / Dynamometer to the DC Motor / Generator using a timing belt.

- 2. On the Power Supply, make sure the main power switch is set to the O (off) position, and the voltage control knob is turned fully counterclockwise. Ensure the Power Supply is connected to a three-phase power source.
- 3. Ensure that the flat cable from the computer is connected to the DAI module.

Connect the LOW POWER INPUTs of the DAI and Prime Mover / Dynamometer modules to the 24 V - AC output of the Power Supply.

On the Power Supply, set the 24 V - AC power switch to the I (on) position.

- 4. Start the Metering application.

In the Metering application, open setup configuration file DCMOTOR1.CFG then select custom view 1.

- 5. Set up the separately-excited dc generator circuit shown in Figure 2-31. Notice that no electrical load is connected to the generator output.

Separately-Excited, Shunt, and Compound DC Generators

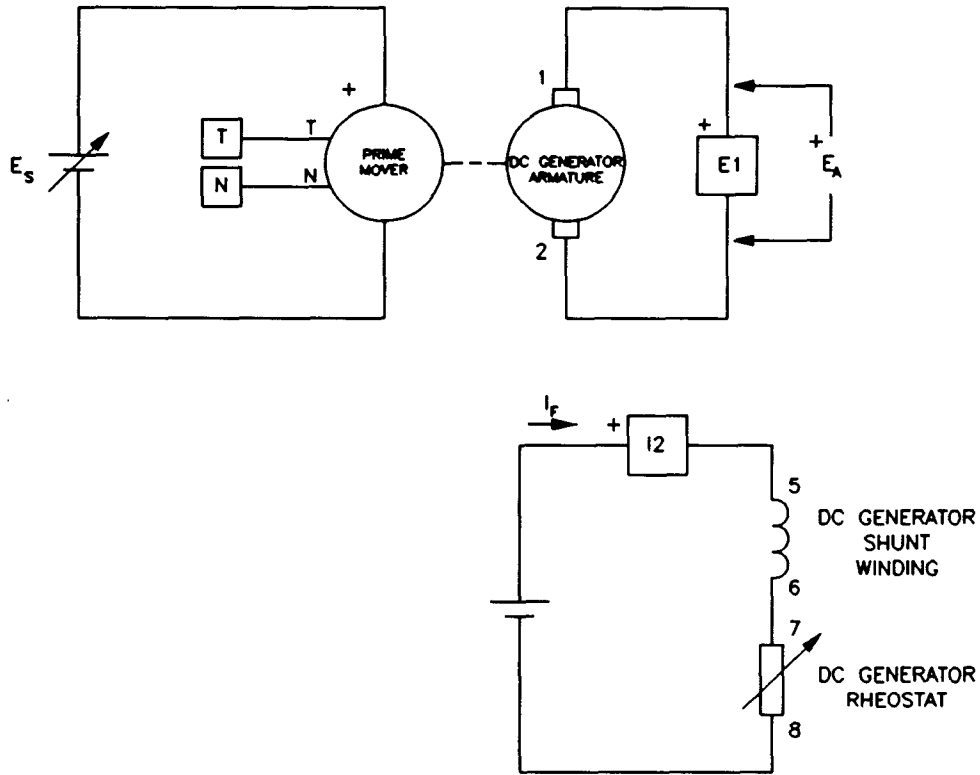

Figure 2-31. Separately-Excited DC Generator Coupled to a Prime Mover (No Electrical Load).

- 6. Set the Prime Mover / Dynamometer controls as follows:

MODE switch PRIME MOVER (P.M.)
 DISPLAY switch SPEED (N)

Note: If you are performing the exercise using LVSIM™-EMS, you can zoom in the Prime Mover / Dynamometer module before setting the controls in order to see additional front panel markings related to these controls.

Output Voltage Versus Speed Characteristic of a Separately-Excited DC Generator

- 7. Turn on the Power Supply.

On the DC Motor / Generator, set the FIELD RHEOSTAT so that the field current I_F indicated by meter I2 in the Metering application is equal to the value given in the following table:

Separately-Excited, Shunt, and Compound DC Generators

| LINE VOLTAGE | FIELD CURRENT I_f |
|-----------------|------------------------|
| V ac | mA |
| 120 | 300 |
| 220 | 190 |
| 240 | 210 |

Table 2-4. Field Current of the Separately-Excited DC Generator.

- 8. In the Metering application, select the torque correction function for meter T. Meter T now indicates the torque produced by the dc generator. This torque opposes to rotation. It is equal in magnitude to the torque applied to the dc generator's shaft but of opposite polarity. This explains why the torque indicated by meter T is negative.

In the Metering application, record the dc generator output voltage E_o , field current I_f , speed n , and torque T (indicated by meters E1, I2, N, and T, respectively) in the Data Table.

On the Power Supply, adjust the voltage control knob to increase the generator speed n by 150 r/min increments up to 1500 r/min (150, 300, 450 r/min etc.). For each speed setting, record the data in the Data Table.

- 9. When all data has been recorded, turn the voltage control knob fully counterclockwise and turn off the Power Supply.

In the Data Table window, confirm that the data has been stored, edit the data table so as to keep only the values of the dc generator output voltage E_o , field current I_f , speed n , and torque T (data in columns E1, I2, N, and T, respectively), entitle the data table as DT231, and print the data table.

Note: Refer to Appendix E of this manual to know how to edit, entitle, and print a data table.

- 10. In the Graph window, make the appropriate settings to obtain a graph of the dc generator output voltage (obtained from meter E1) as a function of the speed n (obtained from meter N). Entitle the graph as G231, name the x-axis as DC Generator Speed, name the y-axis as Separately-Excited DC Generator Output Voltage, and print the graph.

Note: Refer to Appendix E of this manual to know how to use the Graph window of the Metering application to obtain a graph, entitle a graph, name the axes of a graph, and print a graph.

Separately-Excited, Shunt, and Compound DC Generators

Does this graph confirm that the separately-excited dc generator is equivalent to a linear speed-to-voltage converter, with higher speed producing greater output voltage?

Yes No

11. Use the two end points to calculate the slope of the relationship obtained in graph G231. The values of these points are indicated in data table DT231.

$$\text{SLOPE} = \frac{E_2 - E_1}{n_2 - n_1} = \frac{\quad - \quad}{\quad - \quad} = \frac{\quad}{\quad} \frac{\text{V}}{\text{r/min}}$$

Compare the slope of the output voltage versus speed relationship to constant K_1 obtained in Exercise 2-1.

In the Data Table window, clear the recorded data.

Output Current Versus Torque Characteristic of a Separately-Excited DC Generator

12. Modify the connections to connect a resistive load (R_L) across the separately-excited dc generator output as shown in the circuit of Figure 2-32. Connect the three resistor sections on the Resistive Load module in parallel to implement resistor R_L .

13. Turn on the Power Supply.

On the DC Motor/Generator, slightly readjust the FIELD RHEOSTAT so that the field current I_F indicated by meter I2 in the Metering application still equals the value given in Table 2-4 (if necessary).

On the Power Supply, set the voltage control knob so that the Prime Mover rotates at the nominal speed of the DC Motor/Generator.

14. In the Metering application, record the dc generator output voltage E_O , output current I_O , field current I_F , torque T , and speed n (indicated by meters E1, I1, I2, T, and N, respectively) in the Data Table.

Separately-Excited, Shunt, and Compound DC Generators

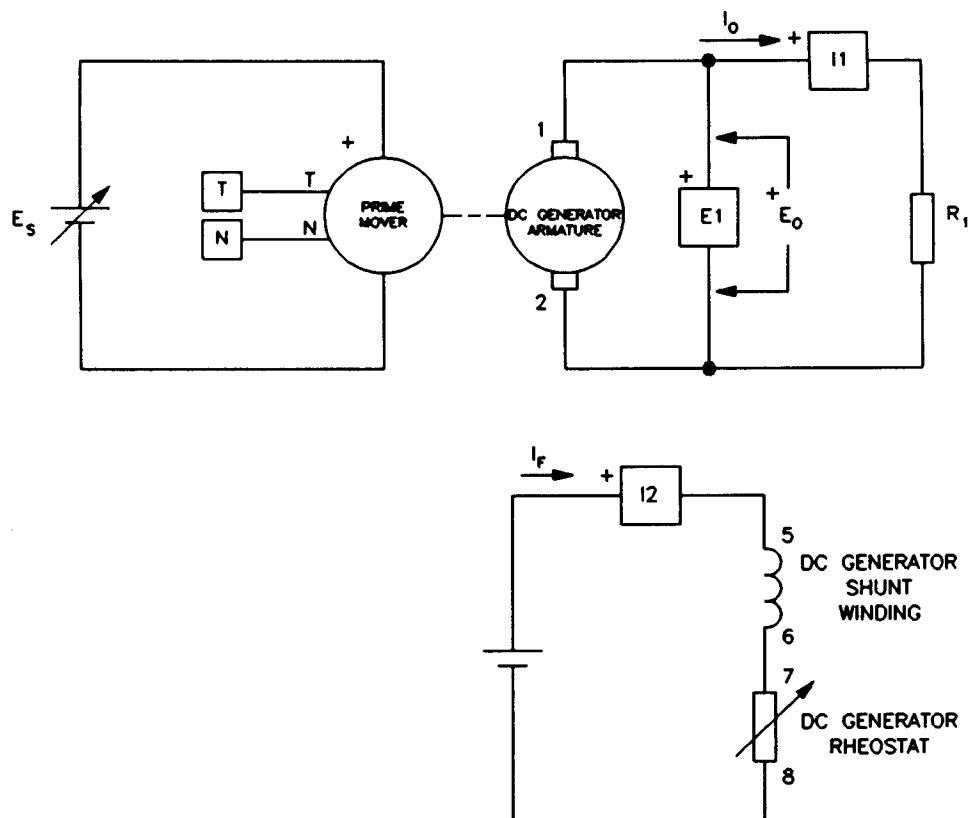

| LINE VOLTAGE (V ac) | R_1 (Ω) |
|---------------------|--------------------|
| 120 | ∞ |
| 220 | ∞ |
| 240 | ∞ |

Figure 2-32. Separately-Excited DC Generator Coupled to a Prime Mover (with an Electrical Load).

Modify the settings on the Resistive Load module so that the resistance of resistor R_1 decreases by steps as indicated in Table 2-5. You can refer to Appendix B of this manual to know how to obtain the various resistance values given in Table 2-5. For each resistance setting, readjust the voltage control knob of the Power Supply so that the Prime Mover speed remains equal to the nominal speed of the DC Motor/Generator and then record the data in the Data Table.

Note: The dc generator output voltage may exceed the rated voltage of the Resistive Load module while performing this manipulation. It is, therefore, suggested to complete the manipulation within a time interval of 5 minutes or less.

Separately-Excited, Shunt, and Compound DC Generators

| LINE VOLTAGE | R ₁ | R ₁ | R ₁ | R ₁ | R ₁ | R ₁ | R ₁ | R ₁ |
|--------------|----------------|----------------|----------------|----------------|----------------|----------------|----------------|----------------|
| V ac | Ω | Ω | Ω | Ω | Ω | Ω | Ω | Ω |
| 120 | 1200 | 600 | 300 | 171 | 120 | 86 | 71 | 57 |
| 220 | 4400 | 2200 | 1100 | 629 | 440 | 314 | 259 | 210 |
| 240 | 4800 | 2400 | 1200 | 686 | 480 | 343 | 282 | 229 |

Table 2-5. Decreasing R₁ to Load the DC Generator.

15. When all data has been recorded, turn the voltage control knob fully counterclockwise and turn off the Power Supply.

In the Data Table window, confirm that the data has been stored, edit the data table so as to keep only the values of the dc generator output voltage E_O, output current I_O, field current I_F, torque T, and speed n (data in columns E1, I1, I2, T, and N, respectively). Reverse the polarity of the torques indicated in column T to obtain the torque applied to the dc generator's shaft. Entitle the data table as DT232, and print the data table.

16. In the Graph window, make the appropriate settings to obtain a graph of the dc generator output current (obtained from meter I1) as a function of the torque T (obtained from meter T). Entitle the graph as G232, name the x-axis as Torque Applied to the DC Generator, name the y-axis as Separately-Excited DC Generator Output Current, and print the graph.

Note: The torque is not zero when the output current is zero because some torque is required to overcome opposition to rotation due to friction in the dc generator.

Does this graph confirm that the separately-excited dc generator is equivalent to a linear torque-to-current converter, with higher torque producing greater output current?

Yes No

17. Use the two end points to calculate the slope of the relationship obtained in graph G232. The values of these points are indicated in data table DT232.

$$\text{SLOPE} = \frac{I_2 - I_1}{T_2 - T_1} = \frac{\quad}{\quad} = \frac{\quad}{\quad} \frac{\text{A}}{\text{N}\cdot\text{m (lbf}\cdot\text{in)}}$$

Separately-Excited, Shunt, and Compound DC Generators

Compare the slope of the output current versus torque relationship to constant K_2 obtained in Exercise 2-1.

Output Voltage Versus Field Current of a Separately-Excited DC Generator

18. On the Resistive Load module, set the resistance of resistor R_1 to the value given in the following table.

| LINE VOLTAGE | R_1 |
|--------------|----------|
| V ac | Ω |
| 120 | 171 |
| 220 | 629 |
| 240 | 686 |

Table 2-6. Resistance of Resistor R_1 .

Turn on the Power Supply.

On the DC Motor/Generator, slightly readjust the FIELD RHEOSTAT so that the field current I_f indicated by meter I2 in the Metering application still equals the value given in Table 2-4 (if necessary).

On the Power Supply, set the voltage control knob so that the Prime Mover rotates at the nominal speed of the DC Motor/Generator.

Note the output voltage E_o and field current I_f indicated by meters E1 and I2 in the following blank spaces:

$$E_o = \text{_____ V} \quad (I_f = \text{_____ A})$$

19. On the DC Motor/Generator, slowly turn the FIELD RHEOSTAT knob fully clockwise so that the field current I_f increases. While doing this, observe the output voltage E_o indicated by meter E1.

Note the output voltage E_o and field current I_f in the following blank spaces:

$$E_o = \text{_____ V} \quad (I_f = \text{_____ A})$$

Separately-Excited, Shunt, and Compound DC Generators

On the DC Motor/Generator, set the FIELD RHEOSTAT to the mid position.

Describe what happens to the output voltage E_o when the field current I_f is increased.

20. On the DC Motor/Generator, slowly turn the FIELD RHEOSTAT knob fully counterclockwise so that the field current I_f decreases. While doing this, observe the output voltage E_o indicated by meter E1.

Note the output voltage E_o and field current I_f in the following blank spaces:

$$E_o = \text{_____ V} \quad (I_f = \text{_____ A})$$

Describe what happens to the output voltage E_o when the field current I_f is decreased.

Is a separately-excited dc generator equivalent to a dc power source with variable output voltage?

Yes No

Turn the voltage control knob fully counterclockwise and turn off the Power Supply.

Voltage Versus Current Characteristic of a Separately-Excited DC Generator Operating at a Fixed Speed

21. In the Graph window, make the appropriate settings to obtain a graph of the separately-excited dc generator output voltage E_o (obtained from meter E1) as a function of the separately-excited dc generator output current I_o (obtained from meter I1) using the data recorded previously in the data table (DT232). Entitle the graph as G232-1, name the x-axis as Separately-Excited DC Generator Output Current, name the y-axis as Separately-Excited DC Generator Output Voltage, and print the graph.

Describe how the output voltage E_o varies as the output current I_o increases.

Separately-Excited, Shunt, and Compound DC Generators

- 22. Set the 24 V - AC power switch to the O (off) position, and remove all leads and cables.

ADDITIONAL EXPERIMENTS

Voltage Versus Current Characteristic of a Shunt Generator Operating at a Fixed Speed

You can obtain the output voltage versus output current characteristic of a shunt generator and compare it to that obtained for the separately-excited dc generator. To do so, make sure the Power Supply is turned off and connect terminals 8 and N of the Power Supply to terminals 5 and 6 of the DC Motor/Generator, respectively. Turn on the Power Supply then turn it off. This sets the polarity of the residual magnetism. Set up the shunt generator circuit shown in Figure 2-33.

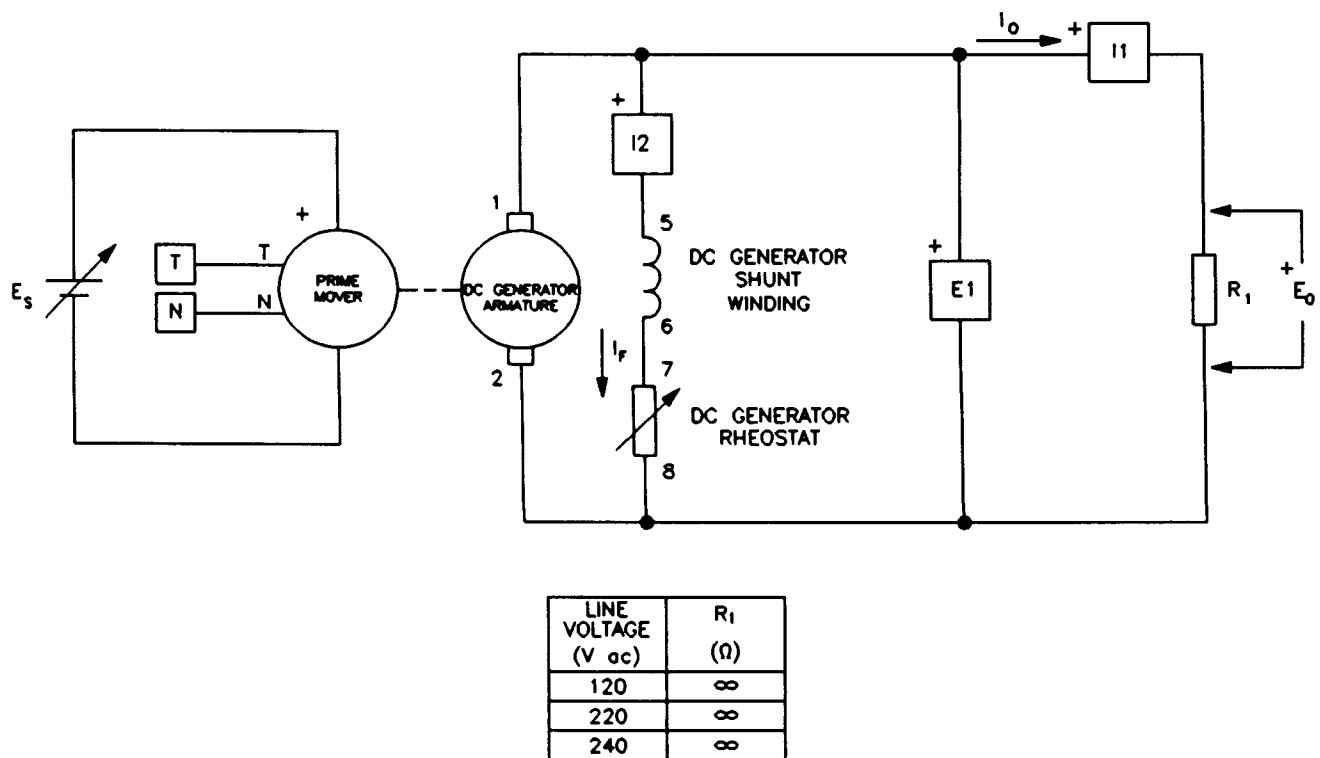

Figure 2-33. Shunt Generator Coupled to a Prime Mover (with an Electrical Load).

Make sure the MODE switch of the Prime Mover / Dynamometer is set to the PRIME MOVER (P.M.) position. Set the FIELD RHEOSTAT on the DC Motor/Generator to the mid position. Turn on the Power Supply and adjust the voltage control knob to set the Prime Mover speed to the nominal speed of the DC Motor/Generator. Slightly turn the FIELD RHEOSTAT on the DC Motor/Generator so that the field current I_F is equal to the value indicated in Table 2-4. Clear the data recorded in the data table. Make sure the torque correction function is selected on meter T of the Metering application. Refer to

Separately-Excited, Shunt, and Compound DC Generators

Sep
anc

steps 14, 15, and 21 of this exercise to record the necessary data and obtain the graph. Entitle the data table and graph as DT233 and G233, respectively. Compare the voltage versus current characteristic of the shunt generator (graph G233) to that of the separately-excited dc generator (graph G232-1).

Note: The output voltage of the separately-excited dc generator decreases rapidly as the output current increases because the armature resistance of the DC Motor/Generator is quite large. This is also due to another phenomenon which is called armature reaction. This phenomenon will be studied in the next unit of this manual.

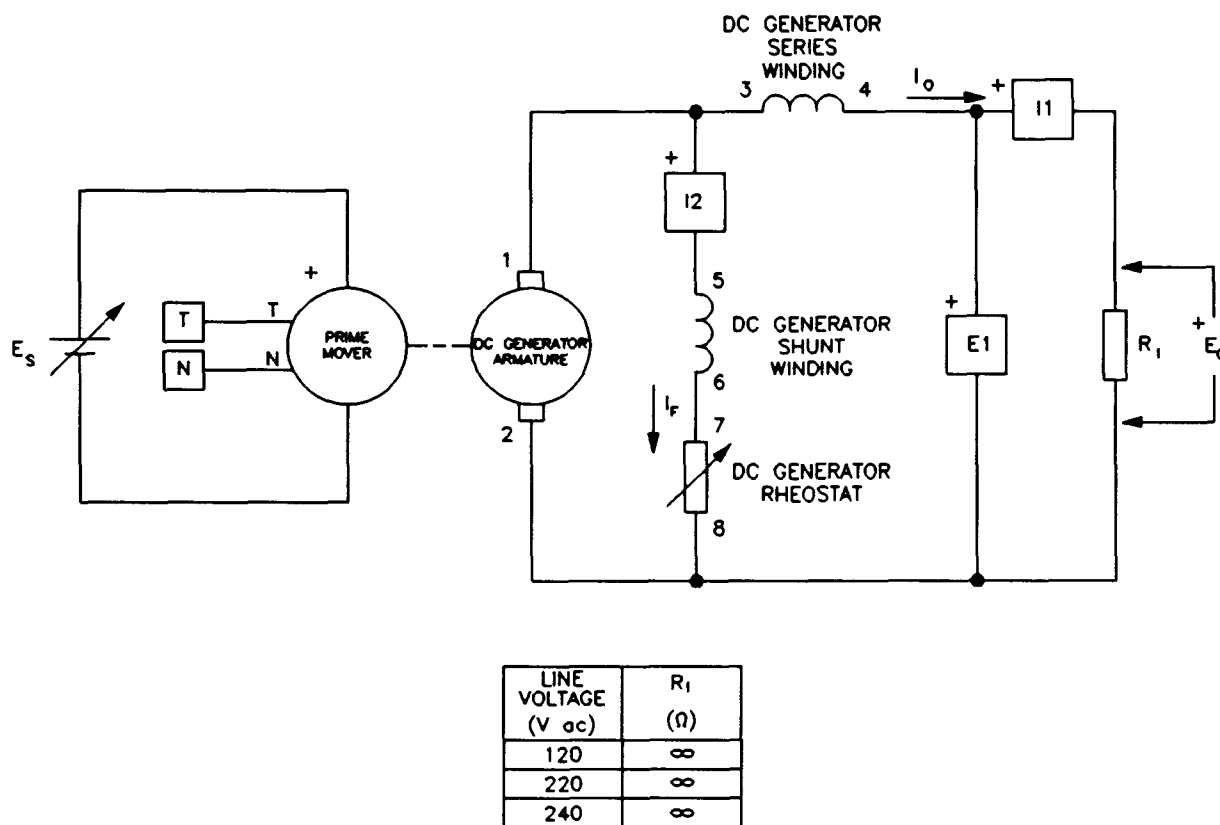

Figure 2-34. Cumulative Compound Generator Coupled to a Prime Mover (with an Electrical Load).

Voltage Versus Current Characteristic of a Cumulative Compound Generator Operating at a Fixed Speed

You can obtain the output voltage versus output current characteristic of a cumulative compound generator and compare it to that obtained for the separately-excited dc generator. To do so, carry out the same manipulations as those used to obtain the voltage versus current characteristic of the shunt generator using the circuit of a cumulative compound generator shown in Figure 2-34. Entitle the data table and graph as DT234 and G234, respectively.

Separately-Excited, Shunt, and Compound DC Generators

Compare the voltage versus current characteristic of the cumulative compound generator (graph G234) to those of the separately-excited dc generator (graph G232-1) and shunt generator (graph G233).

Voltage Versus Current Characteristic of a Differential Compound Generator Operating at a Fixed Speed

You can obtain the output voltage versus output current characteristic of a differential compound generator and compare it to that obtained for the separately-excited dc generator. To do so, carry out the same manipulations as those used to obtain the voltage versus current characteristic of the shunt generator using the circuit of a differential compound generator shown in Figure 2-35. Entitle the data table and graph as DT235 and G235, respectively. Compare the voltage versus current characteristic of the differential compound generator (graph G235) to those obtained with the other types of dc generators (graphs G232-1, G233, and G234).

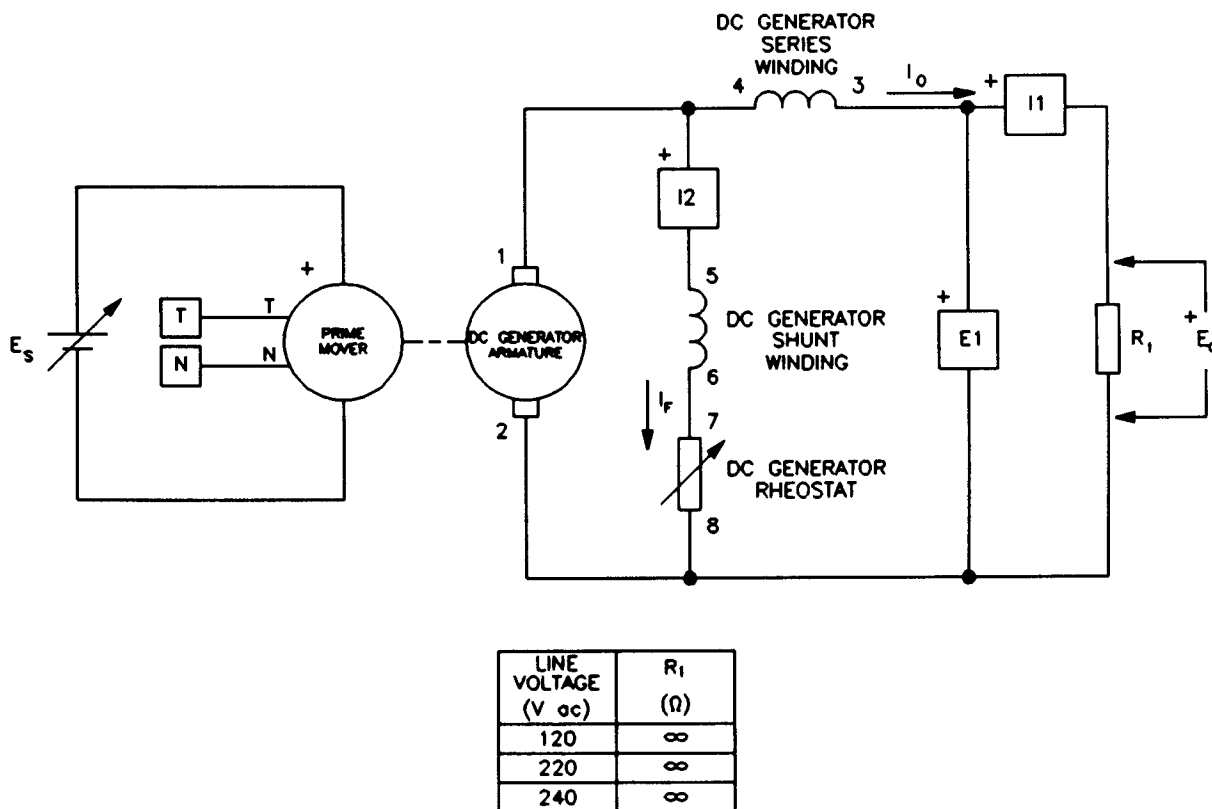

Figure 2-35. Differential Compound Generator Coupled to a Prime Mover (with an Electrical Load).

Separately-Excited, Shunt, and Compound DC Generators

CONCLUSION

In this exercise, you plotted graphs of the main operating characteristics of a separately-excited dc generator. You observed that the output voltage increases linearly with speed. You also observed that the output current increases linearly with the input torque. You found that the slope of the output voltage versus speed characteristic is equal to the reciprocal of constant K_1 , and that the slope of the output current versus torque characteristic is equal to the reciprocal of constant K_2 . You saw that constants K_1 and K_2 can be changed by changing the field current and that this allows the output voltage to be changed. You observed that the output voltage decreases as the output current increases.

If you have performed the additional experiments, you plotted graphs of the voltage versus current characteristics for shunt, cumulative compound, and differential compound generators. You compared the various voltage versus current characteristics obtained in the exercise. You observed that the output voltage of the shunt generator decreases more rapidly than that of the separately-excited dc generator when the output current increases. You found that the output voltage of a cumulative compound generator varies little as the output current varies. Finally, you saw that the output voltage of a differential compound generator decreases more rapidly than that of the separately-excited and shunt generators when the output current increases.

REVIEW QUESTIONS

1. What effect does decreasing the field current have on the output voltage of a separately-excited dc generator operating at fixed speed?
 - a. The output voltage increases.
 - b. The output voltage decreases.
 - c. The output voltage oscillates around its original value.
 - d. The value of the field current has no effect on the output voltage.
2. What effect does increasing the output current have on the input torque of a separately-excited dc generator?
 - a. The torque increases.
 - b. The torque decreases.
 - c. The torque oscillates around its original value.
 - d. The value of output current has no effect on the torque.
3. What is the main characteristic of a cumulative compound generator?
 - a. The output voltage becomes unstable when the output current decreases.
 - b. The output voltage decreases when the output current increases.
 - c. The output voltage increases when the output current increases.
 - d. The output voltage varies little when the output current varies.

Separately-Excited, Shunt, and Compound DC Generators

4. What is the main characteristic of a differential compound generator?
 - a. The output voltage becomes unstable when the output current decreases.
 - b. The output voltage decreases fairly rapidly when the output load current increases.
 - c. The output voltage increases when the output current increases.
 - d. The output voltage is made independent of the output current.

5. What happens when the field current of a separately-excited dc generator is increased and the speed is maintained constant?
 - a. The output current decreases.
 - b. The output voltage increases.
 - c. The output voltage decreases.
 - d. The output voltage is independent of the field current.

Unit Test

1. The rotor, or armature, of a dc motor consists of
 - a. an iron cylinder and windings.
 - b. an iron cylinder, windings, and brushes.
 - c. an iron cylinder, windings, and a commutator.
 - d. an iron cylinder, windings, a commutator, and a dc source.

2. The basic principle of operation of a dc motor is
 - a. the creation of an electromagnet.
 - b. the creation of a rotating electromagnet inside the armature.
 - c. the creation of a fixed electromagnet inside the armature.
 - d. the creation of a rotating electromagnet at the stator.

3. The speed n of a separately-excited dc motor is equal to
 - a. $K_2 \times E_{\text{CEMF}}$.
 - b. $K_1 \times I_A$.
 - c. $K_1 \times E_{\text{CEMF}} \times I_A$.
 - d. $K_1 \times E_{\text{CEMF}}$.

4. The armature resistance R_A and constants K_1 and K_2 of a separately-excited dc motor are 0.2Ω , 8 r/min/V , and $0.8 \text{ N}\cdot\text{m/A}$ ($7.08 \text{ lbf}\cdot\text{in/A}$), respectively. What are the speed n and torque T of this motor knowing that the armature voltage E_A and current I_A are 300 V and 100 A ?
 - a. $n = 2400 \text{ r/min}$, $T = 80 \text{ N}\cdot\text{m}$ ($708 \text{ lbf}\cdot\text{in}$).
 - b. $n = 2240 \text{ r/min}$, $T = 800 \text{ N}\cdot\text{m}$ ($7080 \text{ lbf}\cdot\text{in}$).
 - c. $n = 2240 \text{ r/min}$, $T = 80 \text{ N}\cdot\text{m}$ ($708 \text{ lbf}\cdot\text{in}$).
 - d. $n = 2400 \text{ r/min}$, $T = 240 \text{ N}\cdot\text{m}$ ($2124 \text{ lbf}\cdot\text{in}$).

5. The field current of a separately-excited dc motor operating with a fixed armature voltage and a fixed mechanical load is changed. This causes the speed to increase. The field current has been
 - a. decreased.
 - b. increased.
 - c. This is not possible because the speed is independent of the field current.
 - d. None of the above.

Unit Test (cont'd)

6. When the field current of a separately-excited dc motor is increased,
- constants K_1 and K_2 decrease.
 - constant K_1 decreases and constant K_2 increases.
 - constant K_1 increases and constant K_2 decreases.
 - constants K_1 and K_2 increase.
7. The speed of a separately-excited dc motor
- increases linearly as the motor torque increases.
 - decreases linearly as the motor torque increases.
 - is constant as the motor torque increases.
 - decreases rapidly and non linearly as the motor torque increases.
8. In a series motor, the field electromagnet consists of
- a winding connected in parallel with the armature.
 - a winding connected in parallel with the armature and a second winding connected in series with the armature.
 - a winding connected in series with the armature.
 - a winding connected in series with a separate dc power source.
9. The voltage induced in a separately-excited dc generator (E_{EMF}) that rotates at a fixed speed of 1600 r/min is 600 V. This causes a current of 400 A to flow in the electrical load connected across the dc generator. What is the output voltage E_o of the generator knowing that its armature resistance is 0.15 Ω ?
- $E_o = 360$ V.
 - $E_o = 540$ V.
 - $E_o = 600$ V.
 - $E_o = 200$ V.
10. The output voltage E_o of a cumulative compound generator
- increases linearly as the output current I_o increases.
 - decreases linearly as the output current I_o increases.
 - varies little as the output current I_o increases.
 - decreases rapidly and non linearly as the output current I_o increases.

AC Induction Motors

UNIT OBJECTIVE

After completing this unit, you will be able to demonstrate and explain the operation of ac induction motors using the Squirrel-Cage Induction Motor module and the Capacitor-Start Motor module.

DISCUSSION OF FUNDAMENTALS

As you saw in Unit 1, a voltage is induced between the ends of a wire loop when the magnetic flux linking the loop varies as a function of time. If the ends of the wire loop are short-circuited together, a current flows in the loop. Figure 4-1 shows a magnet that is displaced rapidly towards the right above a group of conductors. The conductors are short-circuited at their extremities by bars A and B and form a type of ladder.

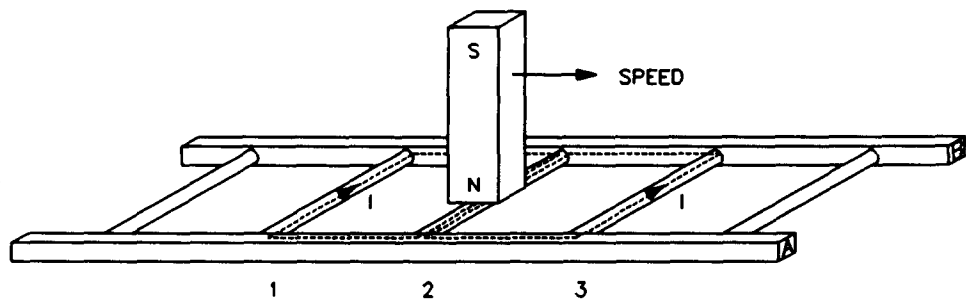

Figure 4-1. Magnet Moving Above a Conducting Ladder.

Current flows in the loop formed by conductors 1 and 2, as well as in the loop formed by conductors 2 and 3. These currents create magnetic fields with north and south poles as shown in Figure 4-2.

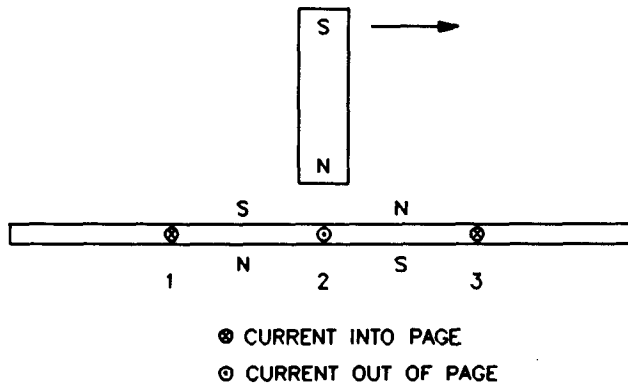

Figure 4-2. Current in the Conductors Creates Magnetic Fields.

AC Induction Motors

The interaction between the magnetic field of the magnet and the magnetic fields produced by the currents induced in the ladder creates a force between the moving magnet and the electromagnet (the conducting ladder). This force causes the ladder to be pulled along in the direction of the moving magnet. However, if the ladder moves at the same speed as the magnet, there is no longer a variation in the magnetic flux. Consequently, there is no induced voltage to cause current flow in the wire loops, meaning that there is no longer a magnetic force acting on the ladder. Therefore, the ladder must move at a speed which is lower than that of the moving magnet for a magnetic force to pull the ladder in the direction of the moving magnet. The greater the speed difference between the two, the greater the variation in magnetic flux, and therefore, the greater the magnetic force acting on the conducting ladder.

The rotor of an asynchronous induction motor is made by closing a ladder similar to that shown in Figure 4-1 upon itself to form a type of squirrel cage as shown in Figure 4-3. This is where the name squirrel-cage induction motor comes from.

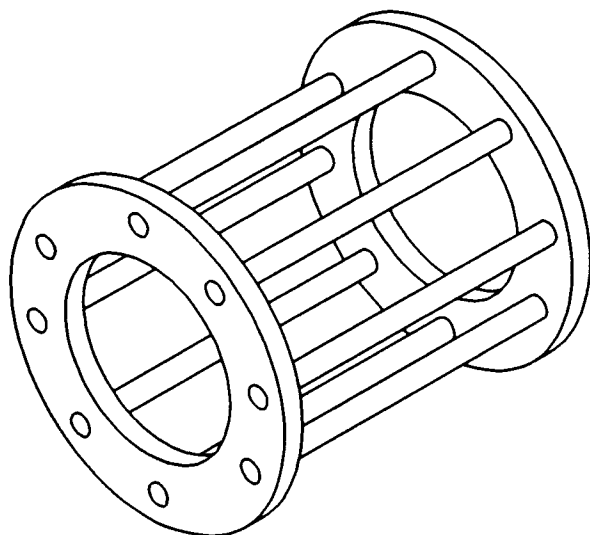

Figure 4-3. Closing a Ladder Upon Itself Forms a Squirrel Cage.

To make it easier for the magnetic flux to circulate, the rotor of a squirrel-cage induction motor is placed inside a laminated iron cylinder. The stator of the induction motor acts as a rotating electromagnet. The rotating electromagnet causes torque which pulls the rotor along in much the same manner as the moving magnet in Figure 4-1 pulls the ladder.

Exercise 4-1

The Three-Phase Squirrel-Cage Induction Motor

EXERCISE OBJECTIVE

When you have completed this exercise you will be able to demonstrate the operating characteristics of a three-phase induction motor using the Four-Pole Squirrel-Cage Induction Motor module.

DISCUSSION

One of the ways of creating a rotating electromagnet is to connect a three-phase power source to a stator made of three electromagnets A, B, and C, that are placed at 120° to one another as shown in Figure 4-4.

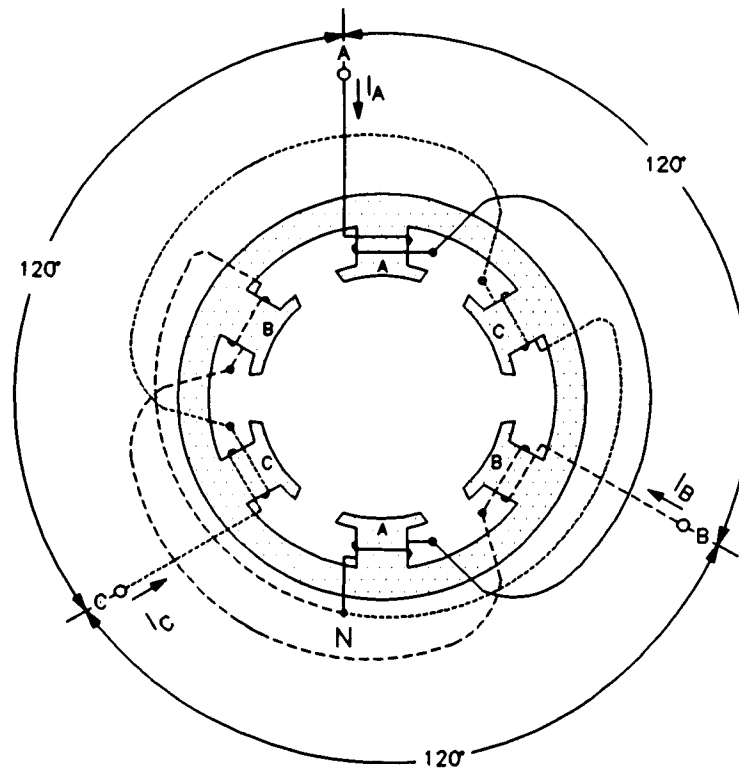

Figure 4-4. Three-Phase Stator Windings.

When sine-wave currents phase shifted of 120° to each other, like those shown in Figure 4-5, flow in stator electromagnets A, B, and C, a magnetic field that rotates very regularly is obtained.

The Three-Phase Squirrel-Cage Induction Motor

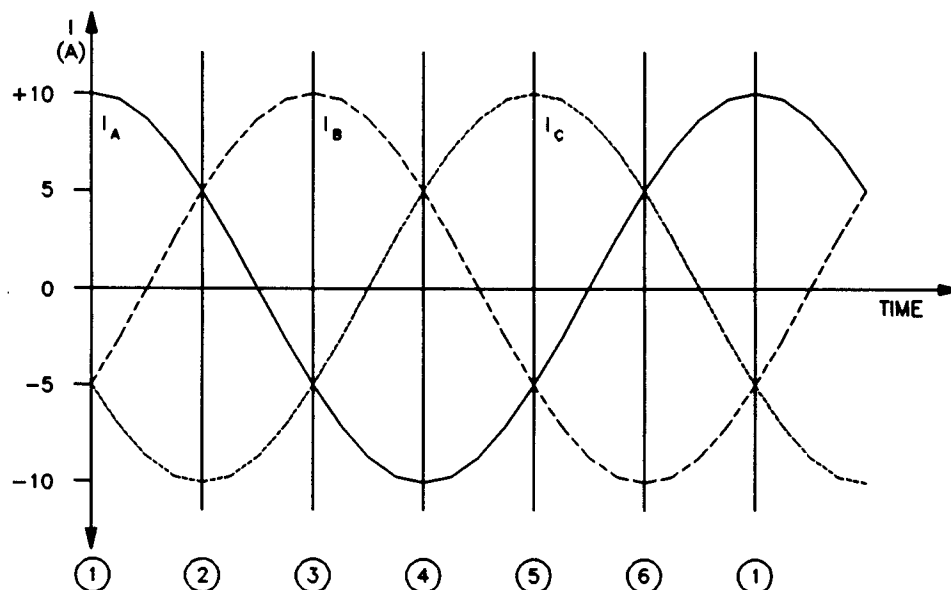

Figure 4-5. Three-Phase Sine-Wave Currents Flowing in the Stator Windings.

Figure 4-6 illustrates the magnetic field created by stator electromagnets A, B, and C at instants numbered 1 to 6 in Figure 4-5. Notice that the magnetic lines of force exit at the north pole of each electromagnet and enter at the south pole. As can be seen, the magnetic field rotates clockwise.

The use of sine-wave currents produces a magnetic field that rotates regularly and whose strength does not vary over time. The speed of the rotating magnetic field is known as the synchronous speed (n_s) and is proportional to the frequency of the ac power source. A rotating magnetic field can also be obtained using other combinations of sine-wave currents that are phase-shifted with respect to each other, but three-phase sine-wave currents are used more frequently.

When a squirrel-cage rotor is placed inside a rotating magnetic field, it is pulled around in the same direction as the rotating field. Interchanging the power connections to two of the stator windings (interchanging A with B for example) interchanges two of the three currents and reverses the phase sequence. This causes the rotating field to reverse direction. As a result, the direction of rotation of the motor is also reversed.

The Three-Phase Squirrel-Cage Induction Motor

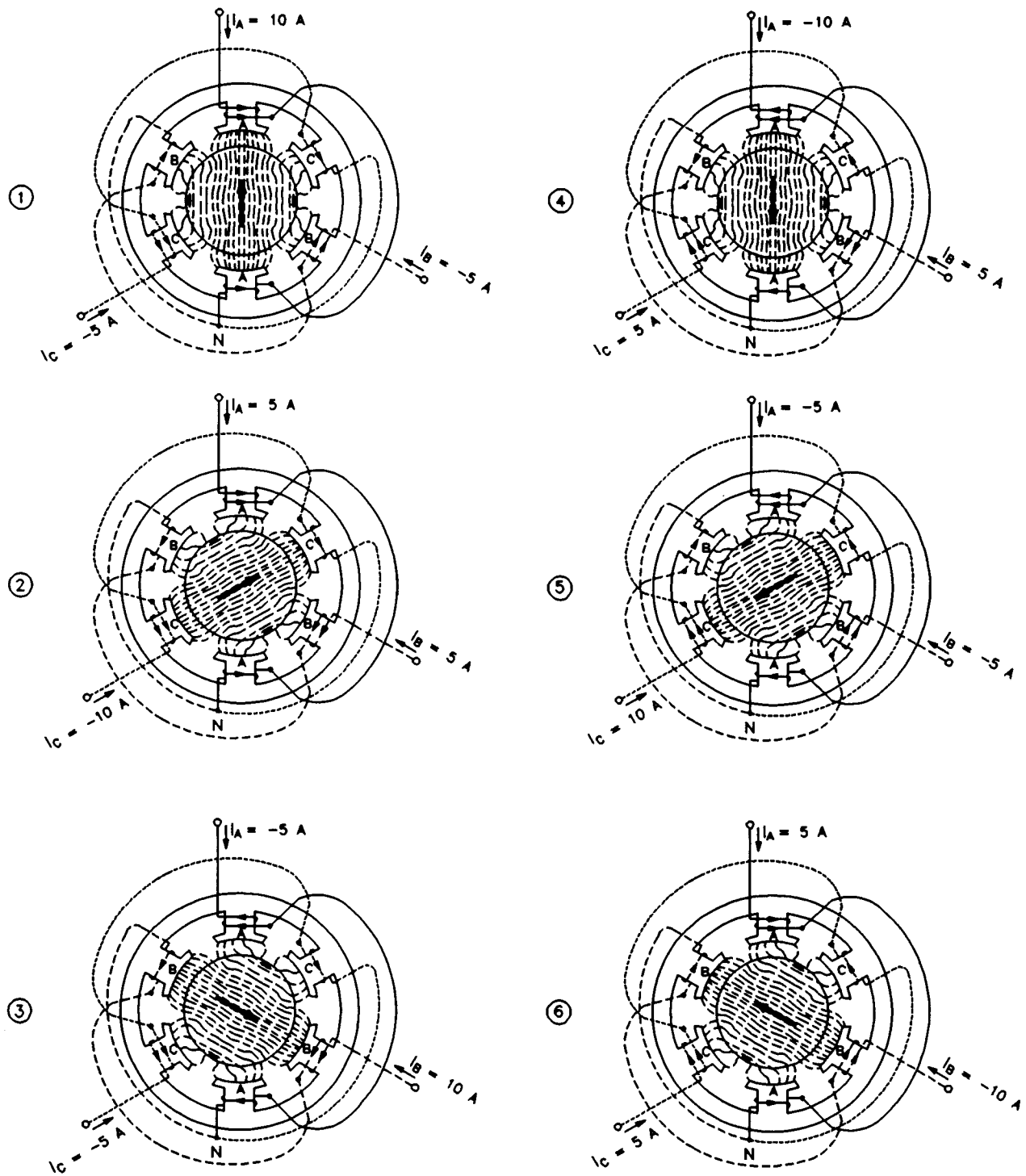

Figure 4-6. Position of the Rotating Magnetic Field at Various Instants. (From *Electrical Machines, Drives, and Power Systems* by Theodore Wildi. Copyright © 1991, 1981 Sperika Enterprises Ltd. © Published by Prentice Hall. All rights reserved.)

The Three-Phase Squirrel-Cage Induction Motor

Referring to what has been said in the Discussion of Fundamentals of this unit, one can easily deduce that the torque produced by a squirrel-cage induction motor increases as the difference in speed between the rotating magnetic field and the rotor increases. The difference in speed between the two is called **slip**. A plot of the speed versus torque characteristic for a squirrel-cage induction motor gives a curve similar to that shown in Figure 4-7. As can be seen, the motor speed (rotor speed) is always lower than the synchronous speed n_s because slip is necessary for the motor to develop torque. The synchronous speed for the Lab-Volt motors is 1800 r/min for 60-Hz power, and 1500 r/min for 50-Hz power.

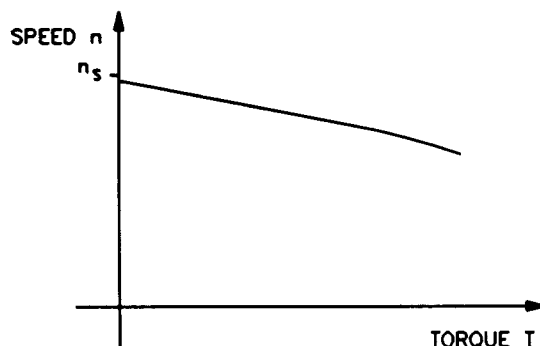

Figure 4-7. Speed Versus Torque Characteristic of a Squirrel-Cage Induction Motor.

The speed versus torque characteristic of the squirrel-cage induction motor is very similar to that obtained previously for a separately-excited dc motor. However, the currents induced in the squirrel-cage rotor must change direction more and more rapidly as the slip increases. In other words, the frequency of the currents induced in the rotor increases as the slip increases. Since the rotor is made up of iron and coils of wire, it has an inductance that opposes rapid changes in current. As a result, the currents induced in the rotor are no longer directly proportional to the slip of the motor. This affects the speed versus torque characteristic as shown in Figure 4-8.

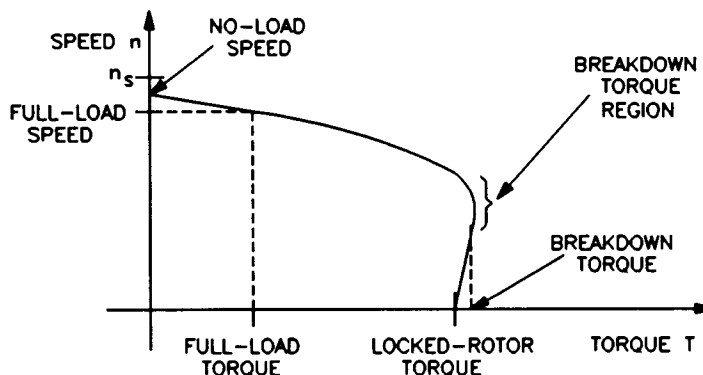

Figure 4-8. The Motor Inductance Affects the Speed Versus Torque Characteristic.

The Three-Phase Squirrel-Cage Induction Motor

As the curve shows, the no-load speed is slightly less than the synchronous speed n_s , but as the load torque increases, motor speed decreases. For the nominal value of motor torque (full-load torque) corresponds a nominal operating speed (full-load speed). Further increases in load torque lead to a point of instability, called breakdown torque, after which both motor speed and output torque decrease. The torque value at zero speed, called locked-rotor torque, is often less than the breakdown torque. At start-up, and at low speed, motor current is very high and the amount of power that is consumed is higher than during normal operation.

Another characteristic of three-phase squirrel-cage induction motors is the fact that they always draw reactive power from the ac power source. The reactive power even exceeds the active power when the squirrel-cage induction motor rotates without load. The reactive power is necessary to create the magnetic field in the machine in the same way that an inductor needs reactive power to create the magnetic field surrounding the inductor.

Procedure Summary

In the first part of the exercise, you will set up the equipment in the Workstation, connect the equipment as shown in Figure 4-9, and make the appropriate settings on the Prime Mover / Dynamometer.

In the second part of the exercise, you will apply the nominal line voltage to the squirrel-cage induction motor, note the motor direction of rotation, and measure the motor no-load speed. You will then increase the mechanical load applied to the squirrel-cage induction motor by steps. For each step, you will record in the data table various electrical and mechanical parameters related to the motor. You will then use this data to plot various graphs and determine many of the characteristics of the squirrel-cage induction motor.

In the third part of the exercise, you will interchange two of the leads that supply power to the squirrel-cage induction motor and observe if this affects the direction of rotation.

EQUIPMENT REQUIRED

Refer to the Equipment Utilization Chart in Appendix C to obtain the list of equipment required for this exercise.

PROCEDURE

CAUTION!

High voltages are present in this laboratory exercise! Do not make or modify any banana jack connections with the power on unless otherwise specified!

The Three-Phase Squirrel-Cage Induction Motor

Setting up the Equipment

- 1. Install the Power Supply, Prime Mover / Dynamometer, Four-Pole Squirrel-Cage Induction Motor, and Data Acquisition Interface (DAI) modules in the EMS workstation.

Mechanically couple the Prime Mover / Dynamometer to the Four-Pole Squirrel-Cage Induction Motor.

- 2. On the Power Supply, make sure the main power switch is set to the O (off) position, and the voltage control knob is turned fully counterclockwise. Ensure the Power Supply is connected to a three-phase power source.
- 3. Ensure that the flat cable from the computer is connected to the DAI module.

Connect the LOW POWER INPUTs of the DAI and Prime Mover / Dynamometer modules to the 24 V - AC output of the Power Supply.

On the Power Supply, set the 24 V - AC power switch to the I (on) position.

- 4. Start the Metering application.

In the Metering application, open setup configuration file ACMOTOR1.CFG then select custom view 2.

- 5. Connect the equipment as shown in Figure 4-9.

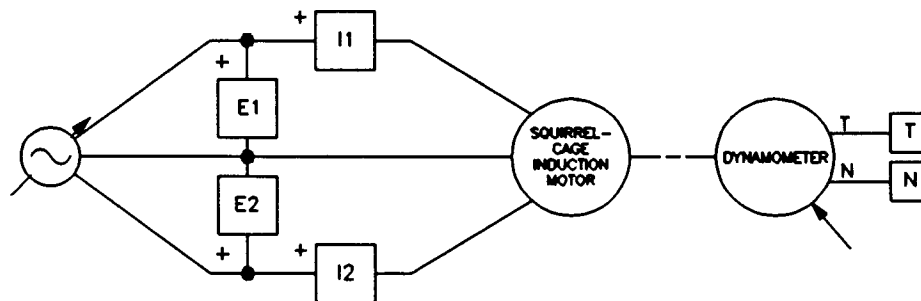

Figure 4-9. Squirrel-Cage Induction Motor Coupled to a Dynamometer.

The Three-Phase Squirrel-Cage Induction Motor

- 6. Set the Prime Mover / Dynamometer controls as follows:

MODE switch DYN.
LOAD CONTROL MODE switch MAN.
LOAD CONTROL knob MIN. (fully CCW)
DISPLAY switch TORQUE (T)

Note: If you are performing the exercise using LVSIM™-EMS, you can zoom in the Prime Mover / Dynamometer module before setting the controls in order to see additional front panel markings related to these controls.

Characteristics of a Squirrel-Cage Induction Motor

- 7. Turn on the Power Supply and set the voltage control knob so that the line voltage indicated by meter E1 is equal to the nominal line voltage of the squirrel-cage induction motor.

Note: The rating of any of the Lab-Volt machines is indicated in the lower left corner of the module front panel. If you are performing the exercise using LVSIM™-EMS, you can obtain the rating of any machine by leaving the mouse pointer on the rotor of the machine of interest. Pop-up help indicating the machine rating will appear after a few seconds.

What is the direction of rotation of the squirrel-cage induction motor?

Record in the following blank space the motor speed indicated by meter N in the Metering application.

n = _____ r/min

Is the no-load speed almost equal to the speed of the rotating magnetic field (synchronous speed) given in the Discussion?

Yes No

- 8. In the Metering application, make sure that the torque correction function of meter T is selected. Meter T indicates the output torque of the squirrel-cage induction motor.

On the Prime Mover / Dynamometer, adjust the LOAD CONTROL knob so that the mechanical power developed by the squirrel-cage induction motor (indicated by meter Pm in the Metering application) is equal to 175 W (nominal motor output power).

The Three-Phase Squirrel-Cage Induction Motor

Record the nominal speed, torque, and line current of the squirrel-cage induction motor in the following blank spaces. The line current is indicated by meter I1.

$$n_{\text{NOM.}} = \text{_____ r/min}$$

$$T_{\text{NOM.}} = \text{_____ N}\cdot\text{m (lbf}\cdot\text{in)}$$

$$I_{\text{NOM.}} = \text{_____ A}$$

On the Prime Mover / Dynamometer, turn the LOAD CONTROL knob fully counterclockwise. The torque indicated on the Prime Mover / Dynamometer display should be 0 N·m (0 lbf·in).

9. Record the motor line voltage E_{LINE} , line current I_{LINE} , active power P , reactive power Q , speed n , and output torque T (indicated by meters E1, I1, C, A, N, and T, respectively) in the Data Table.

On the Prime Mover / Dynamometer, adjust the LOAD CONTROL knob so that the torque indicated on the module display increases by 0.3 N·m (3.0 lbf·in) increments up to 1.8 N·m (15.0 lbf·in). For each torque setting, record the data in the Data Table.

On the Prime Mover / Dynamometer, carefully adjust the LOAD CONTROL knob so that the torque indicated on the module display increases by 0.1 N·m (1.0 lbf·in) increments until the motor speed starts to decrease fairly rapidly (breakdown torque region). For each additional torque setting, record the data in the Data Table.

Once the motor speed has stabilized, record the data in the Data Table.

Note: The nominal line current of the Four-Pole Squirrel-Cage Induction Motor may be exceeded while performing this manipulation. It is, therefore, suggested to complete the manipulation within a time interval of 5 minutes or less.

10. When all data has been recorded, set the LOAD CONTROL knob on the Prime Mover / Dynamometer to the MIN. position (fully CCW), turn the voltage control knob fully counterclockwise, and turn off the Power Supply.

In the Data Table window, confirm that the data has been stored, edit the table so as to keep only the values of the motor line voltage E_{LINE} , line current I_{LINE} , active power P , reactive power Q , speed n , and output torque T (data in columns E1, I1, C, A, N, and T, respectively), entitle the data table as DT411, and print the data table.

Note: Refer to Appendix E of this manual to know how to edit, entitle, and print a data table.

The Three-Phase Squirrel-Cage Induction Motor

Does the motor line current indicated in column I1 increase as the mechanical load applied to the squirrel-cage induction motor increases?

- Yes No

11. In the Graph window, make the appropriate settings to obtain a graph of the motor speed (obtained from meter N) as a function of the motor torque (obtained from meter T). Entitle the graph as G411, name the x-axis as Squirrel Cage Induction Motor Torque, name the y-axis as Squirrel Cage Induction Motor Speed, and print the graph.

Note: Refer to Appendix E of this manual to know how to use the Graph window of the Metering application to obtain a graph, entitle a graph, name the axes of a graph, and print a graph.

Briefly describe how the speed varies as the mechanical load applied to the squirrel-cage induction motor increases, i.e. as the motor torque increases.

12. Indicate on graph G411 the nominal speed and torque of the squirrel-cage induction motor measured previously.

Determine the breakdown torque of the squirrel-cage induction motor using graph G411.

$$T_{\text{BREAKDOWN}} = \text{_____} \text{ N}\cdot\text{m (lbf}\cdot\text{in)}$$

Determine the minimum-speed torque using graph G411. This torque is a good approximation of the locked-rotor torque of the squirrel-cage induction motor.

$$T_{\text{LOCKED ROTOR}} = \text{_____} \text{ N}\cdot\text{m (lbf}\cdot\text{in)}$$

Compare the breakdown torque and locked-rotor torque with the nominal torque of the squirrel-cage induction motor.

The Three-Phase Squirrel-Cage Induction Motor

13. In the Graph window, make the appropriate settings to obtain a graph of the motor active (P) and reactive (Q) powers (obtained from meters C and A, respectively) as a function of the motor speed (obtained from meter N) using the data recorded previously in the data table (DT411). Entitle the graph as G411-1, name the x-axis as Squirrel Cage Induction Motor Speed, name the y-axis as Squirrel Cage Induction Motor Active and Reactive Powers, and print the graph.

Does graph G411-1 confirm that the squirrel-cage induction motor always draws reactive power from the ac power source?

- Yes No

Does graph G411-1 confirm that the squirrel-cage induction motor draws more electrical power from the ac power source as it drives an heavier load?

- Yes No

Observe that when the squirrel-cage induction motor rotates without load, the reactive power exceeds the active power. What does this reveal?

14. In the Graph window, make the appropriate settings to obtain a graph of the motor line current I_{LINE} (obtained from meter I1) as a function of the motor speed (obtained from meter N) using the data recorded previously in the data table (DT411). Entitle the graph as G411-2, name the x-axis as Squirrel Cage Induction Motor Speed, name the y-axis as Squirrel Cage Induction Motor Line Current, and print the graph.

How does the line current varies as the motor speed decreases?

15. Indicate on graph G411-2 the nominal line current of the squirrel-cage induction motor measured previously.

How many times greater than the nominal line current is the starting line current (use the line current measured at minimum speed as the starting current)?

The Three-Phase Squirrel-Cage Induction Motor

Direction of Rotation

16. On the Four-Pole Squirrel-Cage Induction Motor, interchange any two of the three leads connected to the stator windings.

Turn on the Power Supply and set the voltage control knob so that the line voltage indicated by meter E1 is approximately equal to the nominal line voltage of the squirrel-cage induction motor.

What is the direction of rotation of the squirrel-cage induction motor?

Does the squirrel-cage induction motor rotate opposite to the direction noted previously in this exercise?

Yes No

17. Turn the voltage control knob fully counterclockwise and turn off the Power Supply. Set the 24 V - AC power switch to the O (off) position, and remove all leads and cables.

CONCLUSION

In this exercise, you observed that when the nominal line voltage is applied to the stator windings of a squirrel-cage induction motor without mechanical load, the rotor turns at approximately the same speed as the rotating magnetic field (synchronous speed). You saw that interchanging any two of the three leads supplying power to the stator windings reverses the phase sequence, and thereby, causes the motor to rotate in the opposite direction. You observed that the motor line currents increase as the mechanical load increases, thus showing that the squirrel-cage induction motor requires more electric power to drive heavier loads. You plotted a graph of speed versus torque and used it to determine the nominal, breakdown, and locked-rotor torques of the squirrel-cage induction motor. You also plotted a graph of the motor reactive power versus speed and observed that the squirrel-cage induction motor draws reactive power from the ac power source to create its magnetic field. Finally, you plotted a graph of the motor line current versus speed and observed that the starting current is many times greater than the nominal line current.

The Three-Phase Squirrel-Cage Induction Motor

REVIEW QUESTIONS

1. The speed of the rotating magnetic field created by three-phase power is called
 - a. no-load speed.
 - b. synchronous speed.
 - c. slip speed.
 - d. nominal speed.

2. The difference between the synchronous speed and the motor speed of a squirrel-cage induction motor is
 - a. known as slip.
 - b. always greater than 10%.
 - c. known as slip torque.
 - d. always less than 1%.

3. Reactive power is consumed by a squirrel-cage induction motor because
 - a. it uses three-phase power.
 - b. it does not require active power.
 - c. it requires reactive power to create the rotating magnetic field.
 - d. it has a squirrel-cage.

4. Does the speed of a squirrel-cage induction motor increase or decrease when the motor load increases?
 - a. It increases.
 - b. It decreases.
 - c. It stays the same because speed is independent of motor load.
 - d. The speed oscillates around the original value.

5. What happens when two of the three leads supplying power to a squirrel-cage induction motor are reversed?
 - a. The motor does not start.
 - b. Nothing.
 - c. The motor reverses its direction of rotation.
 - d. The motor consumes more reactive power.

Synchronous Motors

UNIT OBJECTIVE

After completing this unit, you will be able to demonstrate and explain the operating characteristics of synchronous motors using the Synchronous Motor / Generator module.

DISCUSSION OF FUNDAMENTALS

The principles of operation of the three-phase synchronous motor are very similar to those of the three-phase squirrel-cage induction motor. The stator is usually built in the same way (refer to Figure 4-4), and it creates a rotating magnetic field the same as illustrated in Figure 4-6. The rotor of the synchronous motor, however, is not a squirrel-cage construction, but rather a permanent magnet or an electromagnet installed on the motor shaft, as shown in Figure 5-1. This rotor is pulled along by the rotating magnetic field exactly as shown in Unit 1.

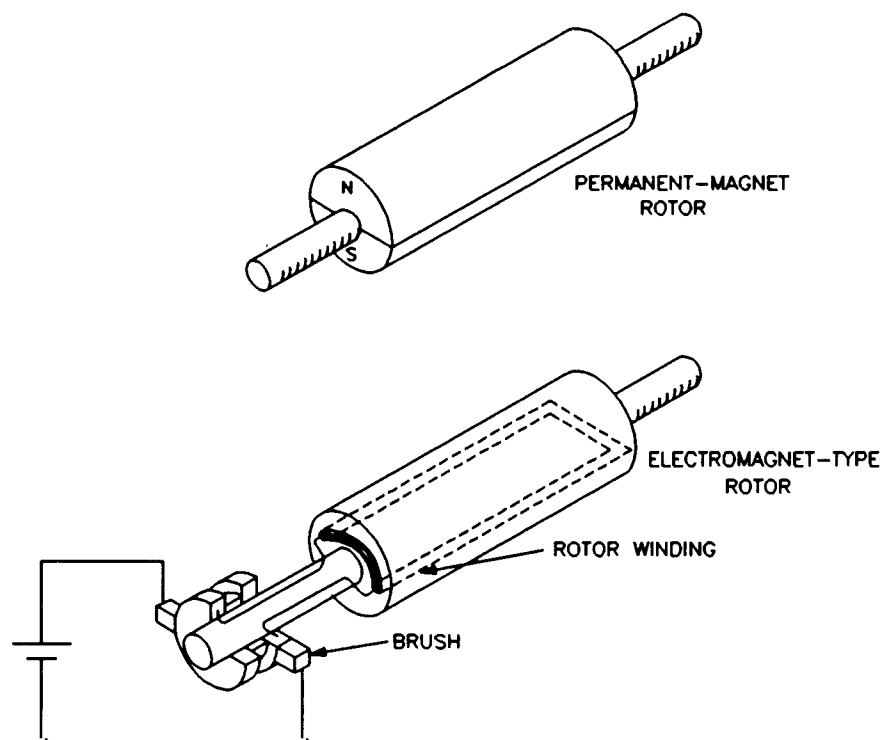

Figure 5-1. Rotor of a Synchronous Motor.

Synchronous Motors

There is, however, a problem when starting a synchronous motor. When three-phase ac power is applied to the stator windings, a rotating magnetic field at synchronous speed n_s is immediately created. Since the rotor is at rest, it cannot catch up to the rotating magnetic field and the resulting torque acting on the rotor is fairly weak.

One way to aid in starting a synchronous motor having a rotor of the electromagnet type is to add a squirrel-cage to the rotor. During start-up, power is removed from the rotor electromagnet and three-phase ac power is applied to the stator windings. A rotating magnetic field is created, currents are induced in the squirrel cage, and the motor starts to rotate like a conventional three-phase squirrel-cage induction motor. When the motor speed stabilizes, dc power is applied to the electromagnet and the rotor locks to the rotating magnetic field and turns at exactly the synchronous speed n_s .

A synchronous motor with a permanent-magnet rotor cannot be started this way because the permanent magnet cannot be turned off. In this case, a variable-frequency ac source is used to supply power to the stator windings of the permanent-magnet synchronous motor. The frequency of the ac source is first set to a low value. This creates a stator magnetic field that rotates at a low speed, and thereby, allows the rotor to catch up to this field. The frequency of the ac source is then increased gradually to increase the speed to the desired value.

Exercise 5-1

The Three-Phase Synchronous Motor

EXERCISE OBJECTIVE

When you have completed this exercise, you will be able to demonstrate how to start a synchronous motor as well as some characteristics of a synchronous motor using the Synchronous Motor/Generator module.

DISCUSSION

The most interesting features of the three-phase synchronous motor are its ability to operate at exactly the same speed as the rotating magnetic field, the capability of running at unity power factor, and to be able to supply reactive power to an ac power source. As seen in Unit 4, an asynchronous motor always consumes reactive power, whether it operates as a motor or a generator. This is because the squirrel-cage induction motor requires reactive power to produce the rotating magnetic field. In the case of the three-phase synchronous motor, the rotating magnetic field is the sum of the magnetic fields produced by the stator and the rotor. If the rotor field is weak, the stator must contribute almost all the reactive power for the rotating magnetic field. The motor thus consumes reactive power like an inductor or an asynchronous motor. However, if the rotor field is strong, the stator acts to decrease the resulting field, and the motor thus supplies reactive power like a capacitor.

A graph of the reactive power Q versus the field current I_F (current in the rotor electromagnet) of a three-phase synchronous motor operating without load is shown in Figure 5-2. When the field current I_F is minimum, the magnetic field produced by the rotor is weak and the motor consumes a maximum of reactive power (Q is positive). The reactive power that is consumed decreases to zero as current I_F increases because the strength of the magnetic field produced by the rotor increases. When current I_F exceeds a certain value that depends on the characteristics of the motor, the rotor magnetic field is so strong that the motor starts to supply reactive power, i.e. Q becomes negative as illustrated in Figure 5-2.

The graph of the reactive power Q versus the field current I_F shows that a three-phase synchronous motor without load behaves like a three-phase reactive load whose nature (inductive or capacitive) and value depend on the field current I_F . Therefore, three-phase synchronous motors without load are also known as synchronous condensers when used to control the power factor on three-phase power networks.

The Three-Phase Synchronous Motor

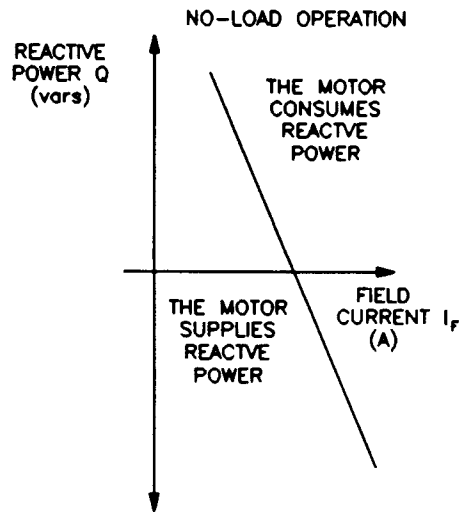

Figure 5-2. Reactive Power Q Versus Field Current I_f for a Three-Phase Synchronous Motor Operating Without Load.

The graph of the line current I_L versus the field current I_f for a three-phase synchronous motor is a "V" type curve like that shown in Figure 5-3. This graph shows that the line current to the motor can be minimized by setting the field current I_f to the appropriate value. The field current required to minimize the line current is the same as that required to decrease the reactive power to zero. Therefore, the motor reactive power is zero when the line current is minimum.

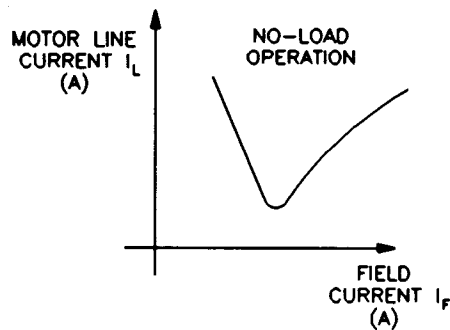

Figure 5-3. Line Current I_L Versus Field Current I_f for a Three-Phase Synchronous Motor Operating Without Load.

The most inconvenient aspect of a three-phase synchronous motor is that it does not start easily, as is explained earlier in this unit.

Procedure Summary

In the first part of the exercise, you will set up the equipment in the Workstation, connect the equipment as shown in Figure 5-4, and make the appropriate settings on the Prime Mover / Dynamometer.

The Three-Phase Synchronous Motor

In the second part of the exercise, you will see how to start a three-phase synchronous motor with a rotor of the electromagnet type. You will also vary the field current to see if it affects the motor speed and line current.

In the third part of the exercise, you will vary the field current by steps. For each step, you will record in the data table various electrical parameters related to the three-phase synchronous motor. You will then use this data to plot various graphs and determine many of the characteristics of the three-phase synchronous motor.

EQUIPMENT REQUIRED

Refer to the Equipment Utilization Chart in Appendix C to obtain the list of equipment required for this exercise.

PROCEDURE

CAUTION!

High voltages are present in this laboratory exercise! Do not make or modify any banana jack connections with the power on unless otherwise specified!

Setting up the Equipment

- 1. Install the Power Supply, Prime Mover / Dynamometer, Synchronous Motor/Generator, Resistive Load, and Data Acquisition Interface (DAI) modules in the EMS workstation.

Mechanically couple the Prime Mover / Dynamometer to the Synchronous Motor/Generator.

- 2. On the Power Supply, make sure the main power switch is set to the O (off) position, and the voltage control knob is turned fully counterclockwise. Ensure the Power Supply is connected to a three-phase power source.
- 3. Ensure that the flat cable from the computer is connected to the DAI module.

Connect the LOW POWER INPUTs of the DAI and Prime Mover / Dynamometer modules to the 24 V - AC output of the Power Supply.

On the Power Supply, set the 24 V - AC power switch to the I (on) position.

- 4. Start the Metering application.

The Three-Phase Synchronous Motor

In the Metering application, open setup configuration file ACMOTOR1.CFG then select custom view 2.

- 5. Connect the equipment as shown in Figure 5-4. Connect the three resistor sections on the Resistive Load module in parallel to implement resistor R_1 .

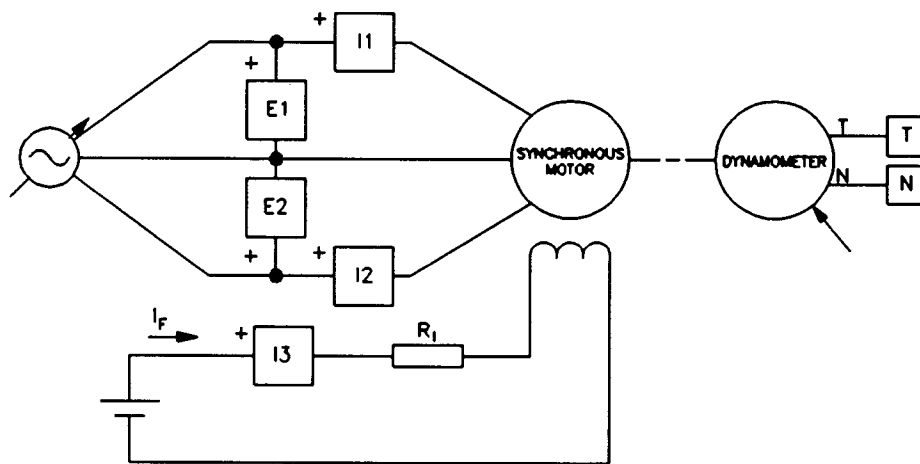

| LINE VOLTAGE (V _{oc}) | R_1 (Ω) |
|---------------------------------|--------------------|
| 120 | 57 |
| 220 | 210 |
| 240 | 229 |

Figure 5-4. Synchronous Motor Coupled to a Dynamometer.

- 6. Set the Prime Mover / Dynamometer controls as follows:

MODE switch DYN.
 LOAD CONTROL MODE switch MAN.
 LOAD CONTROL knob MAX. (fully CW)
 DISPLAY switch SPEED (N)

Note: If you are performing the exercise using LVSIM™-EMS, you can zoom in the Prime Mover / Dynamometer module before setting the controls in order to see additional front panel markings related to these controls.

Starting a Three-Phase Synchronous Motor

- 7. In the Metering application, make sure that the torque correction function of meter T is selected.

On the Synchronous Motor/Generator, set the EXCITER switch to the I (close) position and turn the EXCITER knob fully clockwise.

The Three-Phase Synchronous Motor

Turn on the Power Supply and set the voltage control knob so that the line voltage indicated by meter E1 is equal to the nominal line voltage of the synchronous motor.

Note: The rating of any of the Lab-Volt machines is indicated in the lower left corner of the module front panel. If you are performing the exercise using LVSIM™-EMS, you can obtain the rating of any machine by leaving the mouse pointer on the rotor of the machine of interest. Pop-up help indicating the machine rating will appear after a few seconds.

Record the starting torque T_{START} of the synchronous motor (indicated by meter T in the Metering application) in the following blank space.

$T_{\text{START}} = \underline{\hspace{2cm}}$ N·m (lbf·in) (rotor electromagnet turned on)

8. On the Synchronous Motor/Generator, set the EXCITER switch to the O (open) position.

Record the starting torque T_{START} of the synchronous motor in the following blank space.

$T_{\text{START}} = \underline{\hspace{2cm}}$ N·m (lbf·in) (rotor electromagnet turned off)

Compare the starting torque obtained when the rotor electromagnet is turned off to that obtained when the rotor electromagnet is turned on.

From the results obtained so far, would you conclude that it is desirable to turn off the rotor electromagnet before starting the synchronous motor? Briefly explain.

9. On the Prime Mover / Dynamometer, slowly set the LOAD CONTROL knob to the MIN. (fully CCW) position, wait until the synchronous motor speed stabilizes, and record the motor speed n in the following blank space.

$n = \underline{\hspace{2cm}}$ r/min

The Three-Phase Synchronous Motor

On the Synchronous Motor/Generator, set the EXCITER knob to the mid position then set the EXCITER switch to the I (close) position.

Does the motor speed n change?

- Yes No

Record the motor speed n in the following blank space.

$n = \underline{\hspace{2cm}}$ r/min

Is the motor speed n now equal to the nominal speed of the Synchronous Motor/Generator (synchronous speed n_s)?

- Yes No

10. On the Synchronous Motor/Generator, slowly vary the setting of the EXCITER knob between the MIN. and MAX. positions to vary the field current I_F . While doing this, observe the motor speed n and the motor line current I_{LINE} indicated by meter I1.

Does varying the field current I_F vary the motor speed n ?

- Yes No

Does the motor line current I_{LINE} vary when the field current I_F is varied?

- Yes No

On the Synchronous Motor/Generator, set the EXCITER knob to the MIN. position.

Characteristics of a Three-Phase Synchronous Motor

11. Change the value of resistor R , and vary the setting of the EXCITER knob on the Synchronous Motor/Generator so that the field current passes from the minimum current to the maximum current indicated in the following table, in ten steps that are spaced as equally as possible. Note that it may be necessary to short circuit resistor R , to increase the field current to the maximum value indicated in the table. For each current setting, record the motor line voltage E_{LINE} , line current I_{LINE} , field current I_F , active power P , and reactive power Q (indicated by meters E1, I1, I3, C, and A, respectively) in the data table.

The Three-Phase Synchronous Motor

| LINE VOLTAGE | FIELD CURRENT I_F |
|--------------|---------------------|
| V ac | mA |
| 120 | 300 to 900 |
| 220 | 100 to 500 |
| 240 | 100 to 500 |

Table 5-1. Range of Field Current.

12. When all data has been recorded, turn the voltage control knob fully counterclockwise, and turn off the Power Supply.

In the Data Table window, confirm that the data has been stored, edit the table so as to keep only the values of the motor line voltage E_{LINE} , line current I_{LINE} , field current I_F , active power P , and reactive power Q (data in columns E1, I1, I3, C, and A, respectively), entitle the data table as DT511, and print the data table.

Note: Refer to Appendix E of this manual to know how to edit, entitle, and print a data table.

13. In the Graph window, make the appropriate settings to obtain a graph of the motor line current I_{LINE} (obtained from meter I1) as a function of the field current I_F (obtained from meter I3). Entitle the graph as G511, name the x-axis as Synchronous Motor Field Current, name the y-axis as Synchronous Motor Line Current, and print the graph.

Note: Refer to Appendix E of this manual to know how to use the Graph window of the Metering application to obtain a graph, entitle a graph, name the axes of a graph, and print a graph.

Approximate the field current I_F that minimizes the motor line current I_{LINE} using graph G511. Record your result in the following blank space.

$I_F = \underline{\hspace{2cm}}$ A (for reducing the motor line current to minimum)

14. In the Graph window, make the appropriate settings to obtain a graph of the motor active (P) and reactive (Q) powers (obtained from meters C and A) as a function of the field current I_F (obtained from meter I3) using the data recorded previously in the data table. Entitle the graph as G511-1, name the x-axis as Synchronous Motor Field Current, name the y-axis as Synchronous Motor Active and Reactive Powers, and print the graph.

The Three-Phase Synchronous Motor

Does varying the field current I_f vary the active power consumed by the synchronous motor significantly?

- Yes No

How does the motor reactive power Q vary when the field current I_f increases?

Could a synchronous motor operating without load be used to improve the power factor of a three-phase power network? Briefly explain.

15. Determine the field current I_f for which the reactive power Q is zero using graph G511-1. Record your result in the following blank space.

$I_f =$ _____ A (for reducing the motor reactive power to zero)

Compare the field current that set the reactive power Q to zero with the field current that minimizes the motor line current I_{LINE} .

From the results obtained so far, can you conclude that the motor line current is minimum when the reactive power is zero?

- Yes No

16. Set the 24 V - AC power switch to the O (off) position, and remove all leads and cables.

CONCLUSION

In this exercise, you saw that the rotor electromagnet must be turned off when starting a synchronous motor, to obtain a higher torque. You observed that once a synchronous motor rotates at a fairly high speed, the rotor electromagnet can be turned on to make the motor turn at the synchronous speed n_s . You found that

The Three-Phase Synchronous Motor

varying the field current I_f of a synchronous motor (current in the rotor electromagnet) varies the motor line current I_{LINE} as well as the motor reactive power Q . You plotted graphs of the motor line current, active power P , and reactive power Q versus the field current. You found that the synchronous motor line current can be minimized by adjusting the field current. You observed that the synchronous motor can either sink or source reactive power depending on the value of the field current. You saw that this allows a three-phase synchronous motor to be used as a synchronous condenser to improve the power factor of a three-phase power network.

REVIEW QUESTIONS

1. The starting torque of a three-phase synchronous motor is increased when
 - a. the rotor electromagnet is turned on.
 - b. the rotor electromagnet is turned off.
 - c. the power factor of the ac power network is unity.
 - d. dc power is applied to one of the stator windings.

2. When a synchronous motor without load is connected to a three-phase ac power network, the resulting power factor depends on
 - a. the speed of the motor.
 - b. the active power consumed by the motor.
 - c. the amount of field current.
 - d. the line current.

3. Reactive power in a synchronous motor without load is minimum when
 - a. the line current is maximum.
 - b. the line current is minimum.
 - c. the line current equals the field current.
 - d. the field current is minimum.

4. Synchronous condenser is another name for
 - a. an asynchronous motor.
 - b. a squirrel-cage motor.
 - c. a split-phase motor.
 - d. a synchronous motor operating without load.

5. The squirrel cage in a synchronous motor with a rotor of the electromagnet type
 - a. minimizes the motor line current.
 - b. prevents saturation of the rotor electromagnet.
 - c. allows the motor to start when ac power is applied to the stator windings.
 - d. allows the motor to operate as a synchronous condenser.

Synchronous Motor Pull-Out Torque

EXERCISE OBJECTIVE

When you have completed this exercise, you will be able to measure the pull-out torque of a synchronous motor using the Synchronous Motor / Generator and Prime Mover / Dynamometer module.

DISCUSSION

One of the important characteristics of the three-phase synchronous motor shown in the previous exercise is that its speed is exactly the same as that of the stator rotating magnetic field (the synchronous speed n_s). When the synchronous motor operates without load torque, the electromagnet rotor is positioned so that its magnetic poles are aligned with those of the rotating magnetic field as shown in Figure 5-5 (a). However, when load torque is applied to the synchronous motor, the electromagnet rotor changes position with respect to the rotating magnetic field, i.e. the rotor falls behind the rotating magnetic field as shown in Figure 5-5 (b).

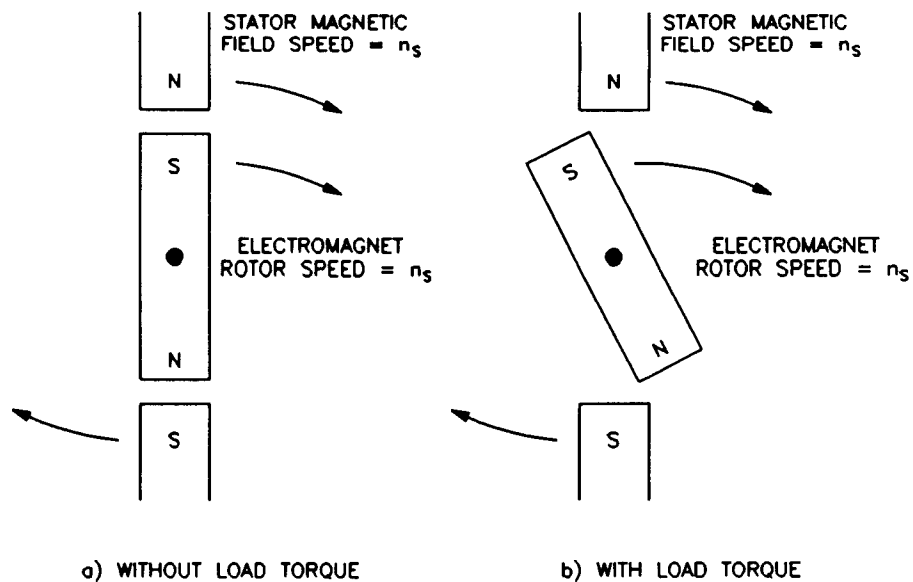

Figure 5-5. Effect of the Load Torque on the Rotor Position in a Synchronous Motor.

The lag of the rotor with respect to the rotating magnetic field of the stator is proportional to the load torque. Therefore, the higher the load torque, the further the rotor lags the rotating magnetic field. When the rotor lags the rotating

Synchronous Motor Pull-Out Torque

magnetic field by 90° , it suddenly pulls out of synchronization with the rotating magnetic field, and the motor speed decreases greatly. Furthermore, the motor line current increases to high values and the motor vibrates. Protection devices should usually be installed on synchronous motors to ensure that the motor suffers no damage when synchronization is lost. The load torque at which synchronization is lost is called pull-out torque.

As might be imagined, higher values of field current I_f allow higher values of pull-out torque to be reached. The graph of pull-out torque versus field current I_f shown in Figure 5-6 indicates that the pull-out torque increases linearly as the field current I_f increases.

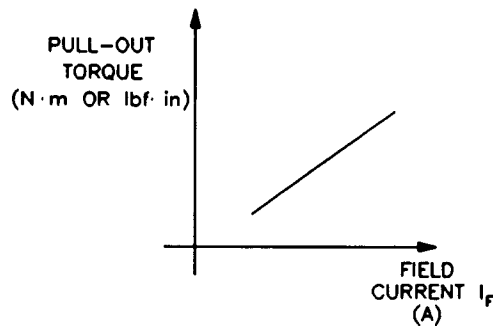

Figure 5-6. The Pull-Out Torque Increases Linearly with the Field Current I_f .

Procedure Summary

In the first part of the exercise, you will set up the equipment in the Workstation, connect the equipment as shown in Figure 5-7, and make the appropriate settings on the Prime Mover / Dynamometer.

In the second part of the exercise, you will set the field current I_f to various values and measure the pull-out torque. This will allow you to demonstrate how the field current I_f affects the pull-out torque.

EQUIPMENT REQUIRED

Refer to the Equipment Utilization Chart in Appendix C to obtain the list of equipment required for this exercise.

PROCEDURE

CAUTION!

High voltages are present in this laboratory exercise! Do not make or modify any banana jack connections with the power on unless otherwise specified!

Synchronous Motor Pull-Out Torque

Setting up the Equipment

- 1. Install the Power Supply, Prime Mover / Dynamometer, Synchronous Motor/Generator, and Data Acquisition Interface (DAI) modules in the EMS workstation.

Mechanically couple the Prime Mover / Dynamometer to the Synchronous Motor/Generator.

- 2. On the Power Supply, make sure the main power switch is set to the O (off) position, and the voltage control knob is turned fully counterclockwise. Ensure the Power Supply is connected to a three-phase power source.

- 3. Ensure that the flat cable from the computer is connected to the DAI module.

Connect the LOW POWER INPUTs of the DAI and Prime Mover / Dynamometer modules to the 24 V - AC output of the Power Supply.

On the Power Supply, set the 24 V - AC power switch to the I (on) position.

- 4. Start the Metering application.

In the Metering application, open setup configuration file ACMOTOR1.CFG then select custom view 2.

- 5. Connect the equipment as shown in Figure 5-7.

On the Synchronous Motor/Generator, make sure that the EXCITER switch is set to the O (open) position and the EXCITER knob is turned fully counterclockwise.

- 6. Set the Prime Mover / Dynamometer controls as follows:

| | | |
|--------------------------|-------|------------------|
| MODE switch | | DYN. |
| LOAD CONTROL MODE switch | | MAN. |
| LOAD CONTROL knob | | MIN. (fully CCW) |
| DISPLAY switch | | TORQUE (T) |

Note: If you are performing the exercise using LVSIM™-EMS, you can zoom in the Prime Mover / Dynamometer module before setting the controls in order to see additional front panel markings related to these controls.

In the Metering application, make sure that the torque correction function of meter T is selected.

Synchronous Motor Pull-Out Torque

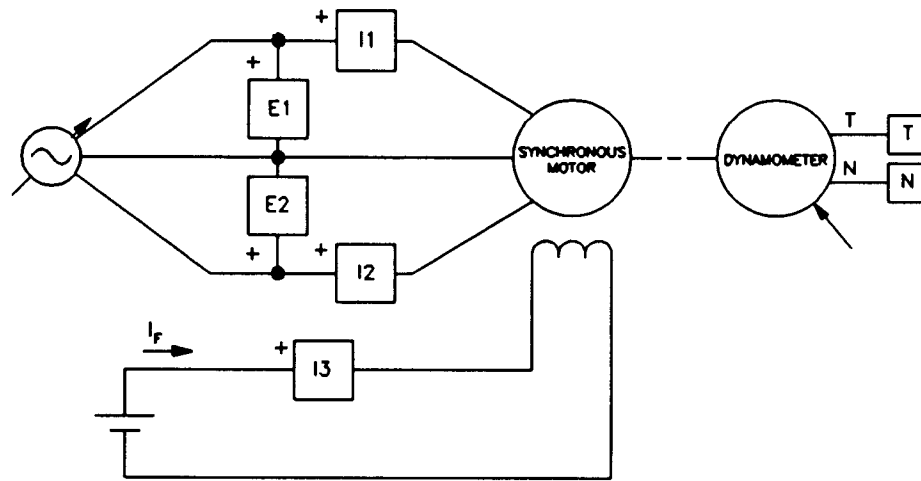

Figure 5-7. Synchronous Motor Coupled to a Dynamometer.

Synchronous Motor Pull-Out Torque

- 7. Turn on the Power Supply and set the voltage control knob so that the line voltage indicated by meter E1 is equal to the nominal line voltage of the synchronous motor. Wait for the speed of the synchronous motor to stabilize.

Note: The rating of any of the Lab-Volt machines is indicated in the lower left corner of the module front panel. If you are performing the exercise using LVSIM™-EMS, you can obtain the rating of any machine by leaving the mouse pointer on the rotor of the machine of interest. Pop-up help indicating the machine rating will appear after a few seconds.

On the Synchronous Motor/Generator, set the EXCITER switch to the I (close) position. The synchronous motor should rotate at synchronous speed.

- 8. Record in the following blank space the field current I_F of the synchronous motor indicated by meter I3 in the Metering application.

$$I_F = \text{_____ A}$$

On the Prime Mover / Dynamometer, slowly turn the LOAD CONTROL knob clockwise until the synchronous motor pulls out of synchronization. While doing this, observe the synchronous motor torque and line current indicated by meters T and I1 in the Metering application. Record in the

Synchronous Motor Pull-Out Torque

following blank spaces the motor torque indicated by meter T when the motor pulls out of synchronization and the motor line current indicated by meter I1 just before the motor pulls out of synchronization.

$$T_{\text{PULL OUT}} = \text{_____ N}\cdot\text{m (lbf}\cdot\text{in)}$$

$$I_{\text{LINE}} = \text{_____ A (motor in synchronization)}$$

Record in the following blank spaces the synchronous motor line current and speed indicated by meters I1 and N in the Metering application.

$$I_{\text{LINE}} = \text{_____ A (motor out of synchronization)}$$

$$n = \text{_____ r/min (motor out of synchronization)}$$

Turn off the Power Supply.

On the Synchronous Motor/Generator, set the EXCITER switch to the O position.

On the Prime Mover / Dynamometer, set the LOAD CONTROL knob to the MIN. (fully CCW) position.

9. Describe how the speed varies when the synchronous motor pulls out of synchronization.

How does the motor line current vary when the synchronous motor pulls out of synchronization?

10. Repeat steps 7 and 8 with the EXCITER knob on the Synchronous Motor/Generator set to the one-quarter, one-half, three-quarter, and maximum positions. For each setting of the EXCITER knob, record the values of the field current I_F and pull-out torque $T_{\text{PULL OUT}}$ in the following blank spaces.

EXCITER knob set to one quarter of maximum

$$I_F = \text{_____ A}$$

$$T_{\text{PULL OUT}} = \text{_____ N}\cdot\text{m (lbf}\cdot\text{in)}$$

Synchronous Motor Pull-Out Torque

EXCITER knob set to one half the maximum

$$I_F = \text{_____ A}$$

$$T_{\text{PULL OUT}} = \text{_____ N}\cdot\text{m (lbf}\cdot\text{in)}$$

EXCITER knob set to three quarter of maximum

$$I_F = \text{_____ A}$$

$$T_{\text{PULL OUT}} = \text{_____ N}\cdot\text{m (lbf}\cdot\text{in)}$$

EXCITER knob set to maximum

$$I_F = \text{_____ A}$$

$$T_{\text{PULL OUT}} = \text{_____ N}\cdot\text{m (lbf}\cdot\text{in)}$$

11. In the Data Table, insert five blank lines in the data table then record the values of the field current I_F and pull-out torque $T_{\text{PULL OUT}}$ obtained in steps 8 and 10 in columns I3 and T of the data table, respectively.

Entitle the data table as DT521, and print the data table.

Note: Refer to Appendix E of this manual to know how to edit, entitle, and print a data table.

12. In the Graph window, make the appropriate settings to obtain a graph of the pull-out torque $T_{\text{PULL OUT}}$ (obtained from meter T) as a function of the field current I_F (obtained from meter I3). Entitle the graph as G521, name the x-axis as Synchronous Motor Field Current, name the y-axis as Synchronous Motor Pull-Out Torque, and print the graph.

Note: Refer to Appendix E of this manual to know how to use the Graph window of the Metering application to obtain a graph, entitle a graph, name the axes of a graph, and print a graph.

Does graph G521 demonstrate that the pull-out torque of the synchronous motor increases for higher values of field current?

Yes No

13. Set the 24 V - AC power switch to the O (off) position, and remove all leads and cables.

Synchronous Motor Pull-Out Torque

CONCLUSION

In this exercise, you demonstrated the loss of synchronization between the rotor and the stator rotating magnetic field when the load on a synchronous motor is greater than the pull-out torque. You also observed that the pull-out torque is greater for higher values of field current.

REVIEW QUESTIONS

1. When load torque is applied to a synchronous motor
 - a. the motor slows down.
 - b. the motor speeds up.
 - c. the rotor position falls behind the rotating magnetic field.
 - d. the stator starts to rotate.

2. Pull-out torque is
 - a. the minimum value of load torque that causes the nominal line current of a synchronous motor to be exceeded.
 - b. the torque at which a synchronous motor pulls out of synchronization.
 - c. the maximum torque for the minimum field current.
 - d. the minimum torque that a synchronous motor can supply.

3. The synchronous motor in Figure 5-5 pulls out of synchronization when the rotor has shifted
 - a. 30° behind the rotating magnetic field.
 - b. 90° ahead of the rotating magnetic field.
 - c. 30° ahead of the rotating magnetic field.
 - d. 90° behind the rotating magnetic field.

4. When the field current in a synchronous motor is increased, the pull-out torque
 - a. decreases.
 - b. increases.
 - c. does not change.
 - d. increases momentarily until speed stabilizes.

5. What happens when a synchronous motor loses synchronization?
 - a. Nothing.
 - b. The motor speeds up rapidly.
 - c. The motor slows down, the line current increases, and the motor vibrates.
 - d. The motor slows down and its torque increases.

Unit Test

1. A synchronous motor with a permanent-magnet rotor
 - a. is started the same way as a synchronous motor with an electromagnet rotor.
 - b. starts like a squirrel-cage induction motor.
 - c. can be started using a variable-frequency ac power source.
 - d. starts when dc power is applied to the rotor.

2. A three-phase synchronous motor draws reactive power from an ac power source. Decreasing the field current
 - a. will increase the reactive power which the motor draws from the ac power source.
 - b. will decrease the reactive power which the motor draws from the ac power source.
 - c. will decrease the power factor of the motor.
 - d. both a and c.

3. A three-phase synchronous motor supplies reactive power to an ac power source. Decreasing the field current
 - a. will increase the reactive power which the motor supplies to the ac power source.
 - b. will decrease the reactive power which the motor supplies to the ac power source.
 - c. will decrease the power factor of the motor.
 - d. both a and c.

4. A three-phase synchronous motor operates as a synchronous condenser. It is adjusted so that the power factor of the load connected to an ac power source is unity. One of the many inductive loads connected to the ac power source is removed. Therefore,
 - a. the synchronous motor draws more reactive power from the ac power source.
 - b. the synchronous motor supplies more reactive power to the ac power source.
 - c. the field current of the synchronous motor should be decreased to readjust the power factor so that it is unity.
 - d. the field current of the synchronous motor should be increased to readjust the power factor so that it is unity.

5. It is desirable to turn off the rotor electromagnet of a synchronous motor to
 - a. obtain a higher starting torque.
 - b. improve the power factor.
 - c. increase the starting line current.
 - d. increase the pull-out torque.

Unit Test (cont'd)

6. When the line current of a three-phase synchronous motor is minimized, the
 - a. motor is used as a synchronous condenser.
 - b. motor neither draws or supplies reactive power.
 - c. field current is minimum.
 - d. None of the above.

7. The pull-out torque of a synchronous motor depends on
 - a. the power factor.
 - b. the motor line current.
 - c. the field current.
 - d. None of the above.

8. The most interesting features of the three-phase synchronous motor are
 - a. its ability to run at exactly the synchronous speed and to be able to operate as an asynchronous generator.
 - b. its ability to run at exactly the synchronous speed and to be able to supply reactive power to an ac power source.
 - c. the capability of running at unity power factor and to be able to draw reactive power from an ac power source.
 - d. both b and c.

9. A three-phase synchronous motor operating without load acts as
 - a. a resistive load whose value depends on the field current.
 - b. an asynchronous generator operating without load.
 - c. three independent single-phase power sources.
 - d. a reactive load whose nature (inductive or capacitive) and value depend on the field current.

10. A three-phase synchronous motor
 - a. can operate with either ac or dc power.
 - b. does not start easily.
 - c. is another type of ac induction motor.
 - d. with a permanent-magnet rotor is often used as a synchronous condenser to adjust the power factor of an ac power source.

Three-Phase Synchronous Generators (Alternators)

UNIT OBJECTIVE

After completing this unit, you will be able to demonstrate and explain the operating characteristics of three-phase synchronous generators (alternators) using the Synchronous Motor/Generator and Prime Mover / Dynamometer modules.

DISCUSSION OF FUNDAMENTALS

The three-phase synchronous generator, or alternator, produces most of the electricity used today. It is found in all electrical-power generating stations, whether they are of the hydroelectric, diesel, coal-fired, wind turbine, or nuclear type. The alternator also generates the electricity used in motor vehicles like cars and trucks.

The basic principle of operation for alternators is quite simple and can be explained using the simplified single-phase alternator shown in Figure 6-1. An electromagnet creates a magnetic field in the rotor. The electromagnet rotor is

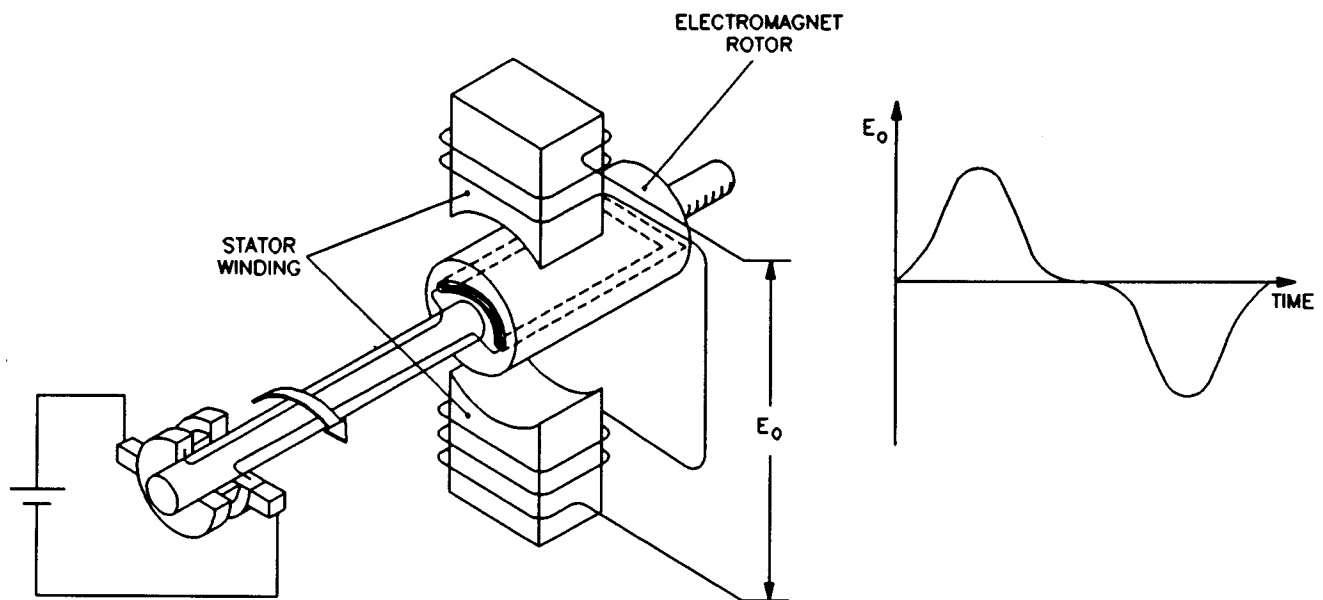

Figure 6-1. An Alternating Voltage is Produced by the Continually-Changing Magnetic Flux Linking the Stator Winding.

Three-Phase Synchronous Generators (Alternators)

coupled to a source of mechanical power, such as a water turbine, to make it rotate. As a result, a continually-changing magnetic flux links the stator winding and induces an alternating voltage across the stator winding as shown in Figure 6-1.

The way the conductors are wound in the stator of a synchronous generator determines the waveform of the voltage induced across the stator winding. The stator-winding conductors in synchronous generators are usually wound in such a way that the induced voltage has a sinusoidal waveform.

The stator in a three-phase synchronous generator is provided with three windings located at 120° from one another. As a result, three sine-wave voltages phase shifted by 120° with respect to each other are induced in the three stator windings. The stator of a three-phase synchronous generator is in fact very similar to the stator of a three-phase squirrel-cage induction motor shown in Figure 4-4.

Exercise 6-1

Synchronous Generator No-Load Operation

EXERCISE OBJECTIVE

When you have completed this exercise, you will be able to demonstrate the no-load operation of a three-phase synchronous generator using the Synchronous Motor/Generator module.

DISCUSSION

In three-phase synchronous generators, the stronger the rotor electromagnet, the greater the magnetic flux linking the stator windings, and the higher the alternating voltages induced across the stator windings. Furthermore, since the induced voltages are proportional to the rate of change of the magnetic flux linking the stator windings, one can easily deduce that the faster the rotor turns, the higher the amplitude of the induced voltages. In brief, the amplitude of the voltages produced by a three-phase synchronous generator is proportional to the strength of the rotor electromagnet and the rotation speed.

There is a direct relationship between the speed of the rotor and the frequency of the voltage induced across each stator winding of a synchronous generator. When the rotor of the synchronous generator shown in Figure 6-1 rotates at a speed of one revolution per second, the frequency of the induced voltage is one hertz. Since speed is usually expressed in revolutions per minute, the equation relating the speed of rotation to the frequency of the voltage produced by the synchronous generator shown in Figure 6-1 is as follows.

$$f = \frac{n}{60} \quad (\text{for generators with a stator having a single pair of poles})$$

where f is the frequency, expressed in hertz (Hz)

n is the speed, expressed in revolutions per minute (r/min)

However, each stator winding in large synchronous generators usually has several north and south poles instead of just a single pair as illustrated in Figure 6-1. As a result, a higher frequency is obtained for a given speed of rotation. The frequency of synchronous generators, regardless of the number of pairs of north and south poles, is determined by simply multiplying the speed n in the previous equation by P , which is the number of pairs of poles of each stator winding. The equation for determining the frequency of the voltage produced by a synchronous generator is thus,

$$f = \frac{n \times P}{60} \quad (\text{for any types of synchronous generators})$$

Synchronous Generator No-Load Operation

Note that the Lab-Volt Synchronous Motor/Generator has two north poles and two south poles per stator winding, thus two pairs of poles per stator winding. Therefore, P equals 2 for the Lab-Volt Synchronous Motor/Generator.

Although small technical differences exist between a synchronous machine designed to operate as a motor and a synchronous machine designed to operate as a generator, both modes of operation can be demonstrated using a same synchronous machine.

Procedure Summary

In the first part of the exercise, you will set up the equipment in the Workstation, connect the equipment as shown in Figure 6-2, and make the appropriate settings on the Prime Mover / Dynamometer.

In the second part of the exercise, you will vary the speed and field current and observe how this affects the no-load operation of a three-phase synchronous generator.

In the third part of the exercise, you will vary the field current of the synchronous generator by steps. For each step, you will record in the data table various electrical parameters related to the three-phase synchronous generator. You will also vary the speed of the synchronous generator by steps while recording various electrical parameters related to the synchronous generator. You will use the recorded data to plot various graphs and determine many of the characteristics of the three-phase synchronous generator.

EQUIPMENT REQUIRED

Refer to the Equipment Utilization Chart in Appendix C to obtain the list of equipment required for this exercise.

PROCEDURE

CAUTION!

High voltages are present in this laboratory exercise! Do not make or modify any banana jack connections with the power on unless otherwise specified!

Setting up the Equipment

- 1. Install the Power Supply, Prime Mover / Dynamometer, Synchronous Motor/Generator, Resistive Load, and Data Acquisition Interface (DAI) modules in the EMS workstation.

Mechanically couple the Prime Mover / Dynamometer to the Synchronous Motor/Generator.

Synchronous Generator No-Load Operation

- 2. On the Power Supply, make sure the main power switch is set to the O (off) position, and the voltage control knob is turned fully counterclockwise. Ensure the Power Supply is connected to a three-phase power source.
- 3. Ensure that the flat cable from the computer is connected to the DAI module.

Connect the LOW POWER INPUTs of the DAI and Prime Mover / Dynamometer modules to the 24 V - AC output of the Power Supply.

On the Power Supply, set the 24 V - AC power switch to the I (on) position.

- 4. Start the Metering application.

In the Metering application, open setup configuration file ACMOTOR1.CFG then select custom view 2.

- 5. Connect the equipment as shown in Figure 6-2.

On the Synchronous Motor/Generator, set the EXCITER switch to the I (close) position and the EXCITER knob to three quarters of maximum.

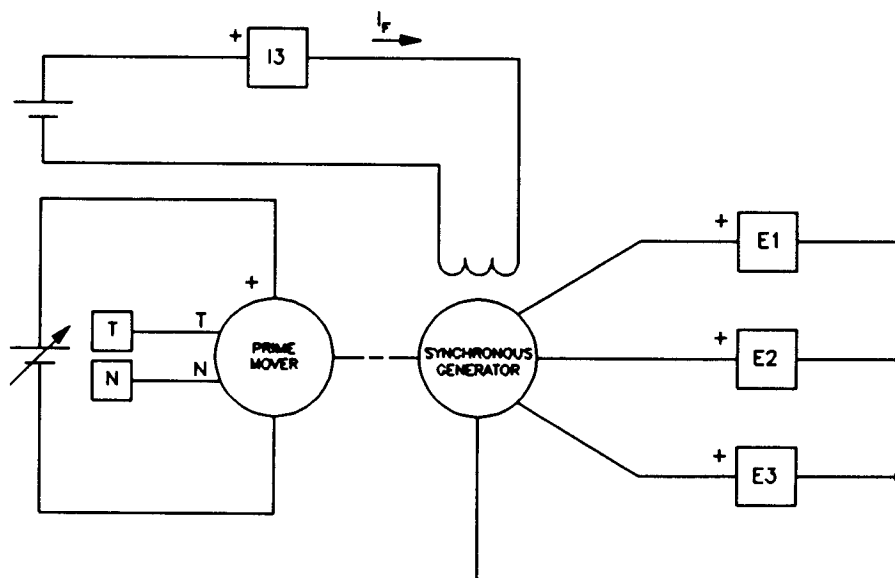

Figure 6-2. Synchronous Generator Coupled to a Prime Mover.

- 6. Set the Prime Mover / Dynamometer controls as follows:

MODE switch PRIME MOVER (P.M.)
 DISPLAY switch SPEED (N)

Synchronous Generator No-Load Operation

Note: If you are performing the exercise using LVSIM™-EMS, you can zoom in the Prime Mover / Dynamometer module before setting the controls in order to see additional front panel markings related to these controls.

Synchronous Generator No-Load Operation

- 7. Turn on the Power Supply and set the voltage control knob so that the Prime Mover rotates at the nominal speed of the Synchronous Motor/Generator.

Note: The rating of any of the Lab-Volt machines is indicated in the lower left corner of the module front panel. If you are performing the exercise using LVSIM™-EMS, you can obtain the rating of any machine by leaving the mouse pointer on the rotor of the machine of interest. Pop-up help indicating the machine rating will appear after a few seconds.

Start the Oscilloscope application and make the appropriate settings to observe the waveforms of voltages E_1 , E_2 , and E_3 induced across each of the stator windings of the synchronous generator.

Note: Do not use the Auto Scale function of the Oscilloscope application to perform this part of the exercise.

Are the waveforms all sinusoidal?

- Yes No

What is the approximate phase shift Φ between each of the voltage waveforms?

$\Phi = \underline{\hspace{2cm}}^\circ$

- 8. In the Oscilloscope application, select the display continuous-refresh function.

Note: If you are performing the exercise using LVSIM™-EMS, do not select the display continuous-refresh function.

On the Power Supply, slowly turn the voltage control knob counterclockwise until the speed of the Prime Mover is approximately 1000 r/min. While doing this, observe the waveforms of voltages E_1 , E_2 , and E_3 in the Oscilloscope application.

Note: If you are performing the exercise using LVSIM™-EMS, refresh the display in the Oscilloscope application a few times while carrying out this manipulation.

Synchronous Generator No-Load Operation

How do the amplitude and frequency of the voltage waveforms vary when the speed of the synchronous generator is decreased? Briefly explain why.

Does varying the speed of the synchronous generator affect the phase shift between the voltage waveforms? Why?

- 9. On the Synchronous Motor/Generator, slowly turn the EXCITER knob counterclockwise to decrease the field current I_F . While doing this, observe the waveforms of voltages E_1 , E_2 , and E_3 in the Oscilloscope application.

Note: If you are performing the exercise using LVSIM™-EMS, refresh the display in the Oscilloscope application a few times while carrying out this manipulation.

How does the amplitude of the voltage waveforms vary when the field current I_F of the synchronous generator is decreased? Briefly explain why.

Does varying the field current I_F of the synchronous generator affect the frequency of the voltage waveforms and the phase shift between the voltage waveforms? Why?

Turn off the Power Supply and turn the voltage control knob fully counterclockwise.

Synchronous Generator No-Load Operation

Characteristics of a Synchronous Generator

- 10. Modify the connections so that the modules are connected as shown in Figure 6-3. Connect the three resistor sections on the Resistive Load module in parallel to implement resistor R_1 .

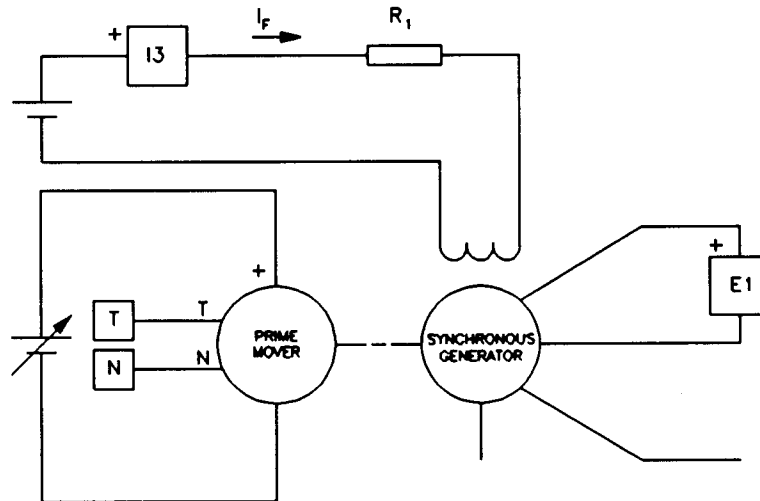

| LINE VOLTAGE (V ac) | R_1 (Ω) |
|---------------------|--------------------|
| 120 | ∞ |
| 220 | ∞ |
| 240 | ∞ |

Figure 6-3. Circuit Used to Observe the No-Load Operation of a Synchronous Generator.

- 11. In the Metering application, make sure that programmable meter B is set as a frequency meter. Meter B will indicate the frequency of the voltage produced by the synchronous generator.

Turn on the Power Supply and set the voltage control knob so that the Prime Mover rotates at the nominal speed of the Synchronous Motor/Generator.

- 12. In the Metering application, record the synchronous generator output voltage E_o , field current I_f , speed n , and frequency f (indicated by meters E1, 13, N, and B, respectively) in the Data Table.

Change the value of resistor R_1 and vary the setting of the EXCITER knob on the Synchronous Motor/Generator to increase the field current I_f to the value indicated in the following table, in ten steps that are spaced as equally as possible. Note that it may be necessary to short circuit resistor R_1 to increase the field current to the maximum value indicated in the table. For each current setting, readjust the voltage control knob

Synchronous Generator No-Load Operation

of the Power Supply so that the Prime Mover speed remains equal to the nominal speed of the Synchronous Motor/Generator, then record the data in the Data Table.

| LINE VOLTAGE | FIELD CURRENT I_f |
|--------------|------------------------|
| V ac | mA |
| 120 | 750 |
| 220 | 450 |
| 240 | 450 |

Table 6-1. Field Current.

13. Short circuit resistor R, using a connection lead.

On the Synchronous Motor/Generator, turn the EXCITER knob fully clockwise to set the field current I_f to maximum.

On the Power Supply, readjust the voltage control knob so that the Prime Mover speed remains equal to the nominal speed of the Synchronous Motor/Generator.

Record the data in the Data Table.

Turn off the Power Supply and turn the voltage control knob fully counterclockwise.

14. In the Data Table window, confirm that the data has been stored, edit the data table so as to keep only the values of the synchronous generator output voltage E_o , field current I_f , speed n , and frequency f (data in columns E1, I3, N, and B, respectively), entitle the data table as DT611, and print the data table.

Note: Refer to Appendix E of this manual to know how to edit, entitle, and print a data table.

15. Record the frequency of the voltages produced by the synchronous generator in the following blank space. This frequency is indicated in column B of the Data Table.

$$f = \text{_____ Hz (measured)}$$

Calculate the theoretical frequency of the voltages produced by the Lab-Volt Synchronous Motor/Generator using the following equation.

$$f = \frac{n \times P}{60} = \text{_____} = \text{_____ Hz}$$

Synchronous Generator No-Load Operation

Compare the measured and calculated frequencies. Are they approximately equal?

Yes No

16. In the Graph window, make the appropriate settings to obtain a graph of the synchronous generator output voltage E_o (obtained from meter E1) as a function of the field current I_f (obtained from meter I3). Entitle the graph as G611, name the x-axis as Synchronous Generator Field Current, name the y-axis as Synchronous Generator Output Voltage, and print the graph.

Note: Refer to Appendix E of this manual to know how to use the Graph window of the Metering application to obtain a graph, entitle a graph, name the axes of a graph, and print a graph.

Observe graph G611. Is the synchronous generator output voltage E_o zero when the field current I_f is zero? Briefly explain why.

Briefly explain why the relationship between the synchronous generator output voltage E_o and field current I_f is non linear for high values of current I_f .

In the Data Table window, clear the recorded data.

17. Turn on the Power Supply.

On the Synchronous Motor/Generator, set the EXCITER knob so that the field current I_f indicated by meter I3 is equal to the value given in the following table.

Synchronous Generator No-Load Operation

| LINE VOLTAGE | FIELD CURRENT I_f |
|--------------|------------------------|
| V ac | mA |
| 120 | 500 |
| 220 | 300 |
| 240 | 300 |

Table 6-2. Field Current of the Synchronous Generator.

18. In the Metering application, record the synchronous generator output voltage E_o , field current I_f , speed n , and frequency f (indicated by meters E1, I3, N, and B, respectively) in the Data Table.

On the Power Supply, adjust the voltage control knob so that the Prime Mover speed increases to the value given in the following table by increments of 200 r/min. For each speed setting, record the data in the Data Table.

| LINE VOLTAGE | MAXIMUM SPEED n_{MAX} |
|--------------|----------------------------|
| V ac | r/min |
| 120 | 2400 |
| 220 | 2000 |
| 240 | 1800 |

Table 6-3. Maximum Speed.

19. When all data has been recorded, turn the voltage control knob fully counterclockwise and turn off the Power Supply.

In the Data Table window, confirm that the data has been stored, edit the data table so as to keep only the values of the synchronous generator output voltage E_o , field current I_f , speed n , and frequency f (data in columns E1, I3, N, and B, respectively), entitle the data table as DT612, and print the data table.

20. In the Graph window, make the appropriate settings to obtain a graph of the synchronous generator output voltage E_o (obtained from meter E1) as a function of the speed n (obtained from meter N). Entitle the graph as G612, name the x-axis as Synchronous Generator Speed, name the y-axis as Synchronous Generator Output Voltage, and print the graph.

Synchronous Generator No-Load Operation

Describe how the synchronous generator output voltage varies as the speed varies.

21. In the Graph window, make the appropriate settings to obtain a graph of the synchronous generator frequency f (obtained from meter B) as a function of the speed n (obtained from meter N). Entitle the graph as G612-1, name the x-axis as Synchronous Generator Speed, name the y-axis as Synchronous Generator Frequency, and print the graph.

Describe how the frequency of the voltages produced by the synchronous generator varies as the speed varies.

22. Set the 24 V - AC power switch to the O (off) position, and remove all leads and cables.

CONCLUSION

In this exercise, you observed that a three-phase synchronous generator produces three sine-wave voltages that are phase shifted by 120° from each other. You saw that decreasing the synchronous generator speed decreases the amplitude and frequency of the sine-wave voltages. You observed that decreasing the field current of the synchronous generator decreases the amplitude of the sine-wave voltages. You plotted a graph of the synchronous generator output voltage versus the field current. This graph showed that the synchronous generator starts to saturate when the field current exceeds a certain value. This graph also showed that the synchronous generator produces voltages even when the field current is zero because of the residual magnetism in the rotor. You plotted graphs of the synchronous generator output voltage and frequency versus speed. These graphs showed that the output voltage and frequency are proportional to the synchronous generator speed.

REVIEW QUESTIONS

1. Most electrical power that is consumed today is produced by
 - a. synchronous condensers.
 - b. synchronous generators.
 - c. alternators.
 - d. both b and c.

Synchronous Generator No-Load Operation

2. When the speed of a synchronous generator is increased
 - a. the output voltage increases and the frequency decreases.
 - b. the output voltage decreases and the frequency increases.
 - c. both the output voltage and frequency decrease.
 - d. both the output voltage and frequency increase.

3. How does the field current affect the frequency of the voltages produced by a three-phase synchronous generator?
 - a. Frequency increases as I_f increases.
 - b. Frequency decreases as I_f decreases.
 - c. Frequency is not affected by changes in field current.
 - d. both a and b.

4. Multiplying the speed of an alternator by $P/60$ allows the
 - a. theoretical frequency to be determined.
 - b. theoretical output voltage to be determined.
 - c. theoretical field current to be determined.
 - d. number of poles to be determined.

5. Alternator is another name for a
 - a. three-phase synchronous motor.
 - b. three-phase synchronous generator.
 - c. three-phase synchronous condenser.
 - d. three-phase ac-to-dc converter.

Exercise 6-2

Voltage Regulation Characteristics

EXERCISE OBJECTIVE

When you have completed this exercise, you will be able to demonstrate the voltage regulation characteristics of a synchronous generator using the Synchronous Motor/Generator module.

DISCUSSION

As seen in Unit 2 of this manual, a dc generator can be represented by the simplified equivalent circuit shown in Figure 6-4. In this circuit, the voltage E_{EMF} depends on the speed at which the generator rotates and the strength of the field electromagnet. Resistor R_A represents the resistance of the armature conductors.

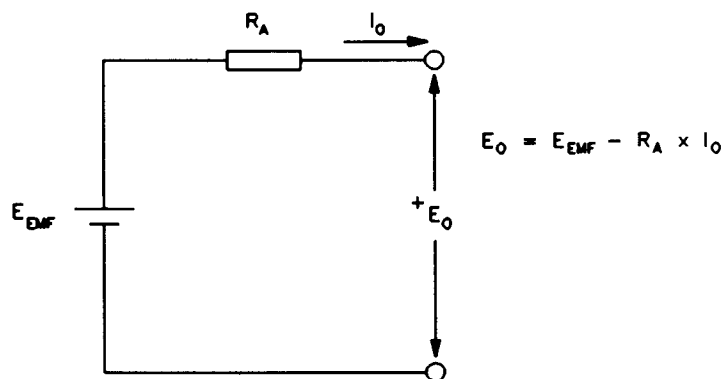

Figure 6-4. Simplified Equivalent Circuit of a DC Generator.

A simplified equivalent circuit similar to that of the dc generator can be used to represent each phase of a three-phase synchronous generator. Figure 6-5 shows the simplified equivalent circuit for one phase of a three-phase synchronous generator. To represent a complete three-phase synchronous generator, three circuits like the one shown in Figure 6-5 would be used.

Voltage Regulation Characteristics

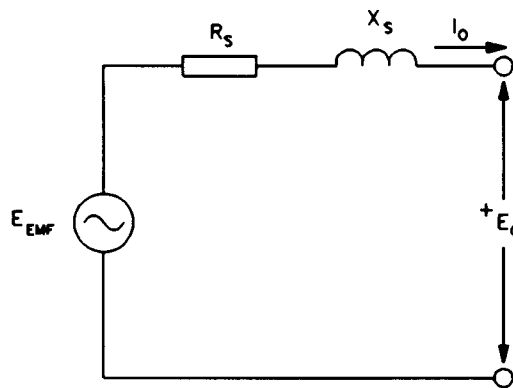

Figure 6-5. Simplified Equivalent Circuit for One Phase of a Three-Phase Synchronous Generator.

As for a dc generator, the voltage E_{EMF} in the simplified circuit of the synchronous generator depends on the rotation speed as well as the strength of the electromagnet. Furthermore, there is a resistor (R_s) in the simplified circuit of the synchronous generator, as in the simplified circuit of the dc generator, that represents the resistance of the stator coil conductors. There is also an additional element in the simplified circuit of the synchronous generator, reactance X_s , which represents the inductive reactance of the stator coil conductors. Reactance X_s is known as the synchronous reactance of the synchronous generator and its value, expressed in ohms, is usually much greater than that of resistor R_s .

When the synchronous generator is operated at constant speed and with a fixed current in the rotor electromagnet (field current I_f), voltage E_{EMF} is constant and the equivalent circuit for each phase is very similar to that of a single-phase transformer, shown in Unit 7 of the student manual entitled *Power Circuits and Transformers*. Figure 6-6 shows voltage regulation characteristics (curves of the output voltage E_o versus the output current I_o) of a synchronous generator for resistive, inductive, and capacitive loads. These characteristics are very similar to those obtained with a single-phase transformer.

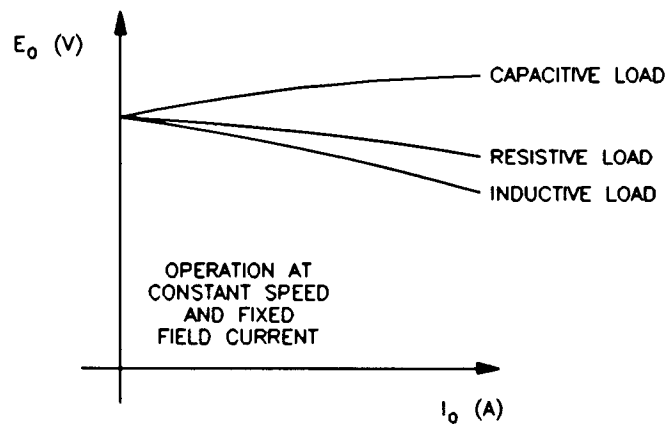

Figure 6-6. Voltage Regulation Characteristics of a Synchronous Generator.

Voltage Regulation Characteristics

Procedure Summary

In the first part of the exercise, you will set up the equipment in the Workstation, connect the equipment as shown in Figure 6-7, and make the appropriate settings on the Prime Mover / Dynamometer.

In the second part of the exercise, you will set the speed of rotation and the field current of the synchronous generator. You will vary the value of the resistive load connected to the generator by steps while maintaining a constant speed. For each load value, you will record the synchronous generator output voltage, output current, field current, and speed. You will use the recorded data to plot a graph of the output voltage versus output current. You will then repeat this part of the exercise twice using an inductive load and a capacitive load.

EQUIPMENT REQUIRED

Refer to the Equipment Utilization Chart in Appendix C to obtain the list of equipment required for this exercise.

PROCEDURE

CAUTION!

High voltages are present in this laboratory exercise! Do not make or modify any banana jack connections with the power on unless otherwise specified!

Setting up the Equipment

- 1. Install the Power Supply, Prime Mover / Dynamometer, Synchronous Motor/Generator, Resistive Load, Inductive Load, Capacitive Load, and Data Acquisition Interface (DAI) modules in the EMS workstation.

Mechanically couple the Prime Mover / Dynamometer to the Synchronous Motor/Generator.

- 2. On the Power Supply, make sure the main power switch is set to the O (off) position, and the voltage control knob is turned fully counterclockwise. Ensure the Power Supply is connected to a three-phase power source.
- 3. Ensure that the flat cable from the computer is connected to the DAI module.

Connect the LOW POWER INPUTs of the DAI and Prime Mover / Dynamometer modules to the 24 V - AC output of the Power Supply.

On the Power Supply, set the 24 V - AC power switch to the I (on) position.

Voltage Regulation Characteristics

- 4. Start the Metering application.

In the Metering application, open setup configuration file ACMOTOR1.CFG then select custom view 2.

- 5. Connect the equipment as shown in Figure 6-7.

On the Synchronous Motor/Generator, set the EXCITER switch to the I (close) position and the EXCITER knob to the mid position.

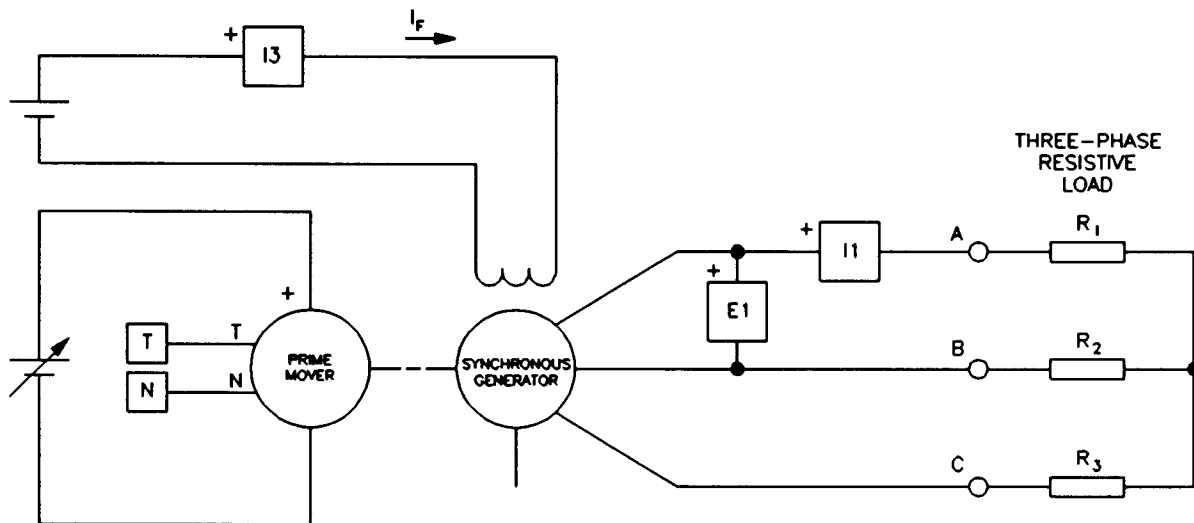

| LINE VOLTAGE (V ac) | R ₁ , R ₂ , R ₃ (Ω) |
|------------------------|---|
| 120 | ∞ |
| 220 | ∞ |
| 240 | ∞ |

Figure 6-7. Synchronous Generator Under Load Coupled to a Prime Mover.

- 6. Set the Prime Mover / Dynamometer controls as follows:

MODE switch PRIME MOVER (P.M.)
 DISPLAY switch SPEED (N)

Note: If you are performing the exercise using LVSIM™-EMS, you can zoom in the Prime Mover / Dynamometer module before setting the controls in order to see additional front panel markings related to these controls.

Voltage Regulation Characteristics

Voltage Regulation Characteristics

- 7. Turn on the Power Supply and set the voltage control knob so that the Prime Mover rotates at the nominal speed of the Synchronous Motor/Generator.

Note: The rating of any of the Lab-Volt machines is indicated in the lower left corner of the module front panel. If you are performing the exercise using LVSIM™-EMS, you can obtain the rating of any machine by leaving the mouse pointer on the rotor of the machine of interest. Pop-up help indicating the machine rating will appear after a few seconds.

- 8. On the Synchronous Motor/Generator, set the EXCITER knob so that the line-to-line output voltage E_o of the synchronous generator (indicated by meter E1 in the Metering application) is equal to the nominal value.

In the Metering application, record the synchronous generator output voltage E_o , output current I_o , field current I_f , and speed n (indicated by meters E1, I1, I3, and N, respectively) in the Data Table.

- 9. Modify the settings on the Resistive Load module so that the resistance of resistors R_1 , R_2 , and R_3 decreases by steps as indicated in Table 6-4. You can refer to Appendix B of this manual to know how to obtain the various resistance values given in Table 6-4. For each resistance setting, readjust the voltage control knob of the Power Supply so that the Prime Mover speed remains equal to the nominal speed of the Synchronous Motor/Generator, then record the data in the Data Table.

| LINE VOLTAGE | R_1, R_2, R_3 | R_1, R_2, R_3 | R_1, R_2, R_3 | R_1, R_2, R_3 | R_1, R_2, R_3 | R_1, R_2, R_3 | R_1, R_2, R_3 |
|--------------|-----------------|-----------------|-----------------|-----------------|-----------------|-----------------|-----------------|
| V ac | Ω | Ω | Ω | Ω | Ω | Ω | Ω |
| 120 | 1200 | 600 | 400 | 300 | 240 | 200 | 171 |
| 220 | 4400 | 2200 | 1467 | 1100 | 880 | 733 | 629 |
| 240 | 4800 | 2400 | 1600 | 1200 | 960 | 800 | 686 |

Table 6-4. Decreasing the Resistance of R_1 , R_2 , and R_3 to Load the Synchronous Generator.

- 10. When all data has been recorded, turn the voltage control knob fully counterclockwise and turn off the Power Supply.
- 11. In the Data Table window, confirm that the data has been stored, edit the data table so as to keep only the values of the synchronous generator output voltage E_o , output current I_o , field current I_f , and speed n , (data in columns E1, I1, I3, and N, respectively), entitle the data table as DT621, and print the data table.

Voltage Regulation Characteristics

Note: Refer to Appendix E of this manual to know how to edit, entitle, and print a data table.

- 12. In the Graph window, make the appropriate settings to obtain a graph of the synchronous generator output voltage E_o (obtained from meter E1) as a function of the output current I_o (obtained from meter I1). Entitle the graph as G621, name the x-axis as Synchronous Generator Output Current, name the y-axis as Synchronous Generator Output Voltage, and print the graph.

Note: Refer to Appendix E of this manual to know how to use the Graph window of the Metering application to obtain a graph, entitle a graph, name the axes of a graph, and print a graph.

Observe graph G621, which shows the voltage regulation characteristic of the synchronous generator when it supplies power to a resistive load. How does the output voltage E_o vary when the output current I_o increases? Briefly explain why.

In the Data Table window, clear the recorded data.

- 13. Replace the three-phase resistive load connected to the synchronous generator output (points A, B, and C in Figure 6-7) with the three-phase inductive load shown in Figure 6-8 (a). Make sure that all switches on the Inductive Load module are opened.

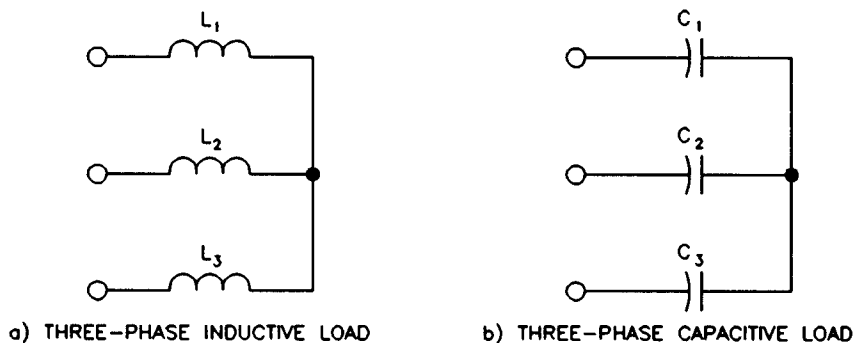

Figure 6-8. Three-Phase Inductive and Capacitive Loads.

- 14. Turn on the Power Supply and set the voltage control knob so that the Prime Mover rotates at the nominal speed of the Synchronous Motor/Generator.

Voltage Regulation Characteristics

On the Synchronous Motor/Generator, set the EXCITER knob so that the line-to-line output voltage E_o of the synchronous generator is equal to the nominal value.

In the Metering application, record the synchronous generator output voltage E_o , output current I_o , field current I_f , and speed n in the Data Table.

- 15. Modify the settings on the load module so that the reactance X of the load decreases by steps as indicated in Table 6-5. You can refer to Appendix B of this manual to know how to obtain the various reactance values given in Table 6-5. For each reactance setting, readjust the voltage control knob of the Power Supply so that the Prime Mover speed remains equal to the nominal speed of the Synchronous Motor/Generator, then record the data in the Data Table.

| LINE VOLTAGE | X_1, X_2, X_3 | X_1, X_2, X_3 | X_1, X_2, X_3 | X_1, X_2, X_3 | X_1, X_2, X_3 | X_1, X_2, X_3 | X_1, X_2, X_3 |
|--------------|-----------------|-----------------|-----------------|-----------------|-----------------|-----------------|-----------------|
| V ac | Ω | Ω | Ω | Ω | Ω | Ω | Ω |
| 120 | 1200 | 600 | 400 | 300 | 240 | 200 | 171 |
| 220 | 4400 | 2200 | 1467 | 1100 | 880 | 733 | 629 |
| 240 | 4800 | 2400 | 1600 | 1200 | 960 | 800 | 686 |

Table 6-5. Decreasing reactances X_1 , X_2 , and X_3 to Load the Synchronous Generator.

- 16. When all data has been recorded, turn the voltage control knob fully counterclockwise and turn off the Power Supply.
- 17. In the Data Table window, confirm that the data has been stored, edit the data table so as to keep only the values of the synchronous generator output voltage E_o , output current I_o , field current I_f , and speed n , (data in columns E1, I1, I3, and N, respectively), entitle the data table as DT622, and print the data table.
- 18. In the Graph window, make the appropriate settings to obtain a graph of the synchronous generator output voltage E_o (obtained from meter E1) as a function of the output current I_o (obtained from meter I1). Entitle the graph as G622, name the x-axis as Synchronous Generator Output Current, name the y-axis as Synchronous Generator Output Voltage, and print the graph.

Voltage Regulation Characteristics

- 19. Observe graph G622, which shows the voltage regulation characteristic of the synchronous generator when it supplies power to an inductive load. How does the output voltage E_o vary when the output current I_o increases?

Compare the voltage regulation characteristics obtained with the resistive load and the inductive load.

In the Data Table window, clear the recorded data.

- 20. Replace the three-phase inductive load connected to the synchronous generator output (points A, B, and C in Figure 6-7) with the three-phase capacitive load shown in Figure 6-8 (b). Make sure that all switches on the Capacitive Load module are opened.

Repeat steps 14 to 18 of this exercise to obtain a graph of the output voltage E_o versus the output current I_o for the synchronous generator supplying power to a capacitive load. Entitle the data table and graph as DT623 and G623, respectively.

Observe graph G623, which shows the voltage regulation characteristic of the synchronous generator when it supplies power to a capacitive load. How does the output voltage E_o vary when the output current I_o increases?

Compare the voltage regulation characteristics of the synchronous generator (graphs G621 to G623) to those obtained with a single-phase transformer in Unit 7 of the student manual entitled *Power Circuits and Transformers*.

Voltage Regulation Characteristics

- 21. Set the 24 V - AC power switch to the O (off) position, and remove all leads and cables.

CONCLUSION

In this exercise, you obtained the voltage regulation characteristics of a three-phase synchronous generator. You observed that the output voltage decreases as the output current increases when the synchronous generator supplies power to either a resistive or inductive load. You saw that the output voltage increases as the output current increases when the synchronous generator supplies power to a capacitive load. You found that the voltage regulation characteristics of the synchronous generator are similar to those of a single-phase transformer because the equivalent circuit is almost the same for both.

REVIEW QUESTIONS

1. The output voltage of a synchronous generator is a function of the
 - a. speed of rotation and polarity of the field current.
 - b. speed of rotation and strength of the field electromagnet.
 - c. speed of rotation and input torque.
 - d. speed of rotation only.

2. The equivalent circuit for one phase of a three-phase synchronous generator operating at constant speed and fixed field current is
 - a. identical to that of a dc generator.
 - b. very similar to that of a single-phase transformer.
 - c. the same as a three-phase balanced circuit.
 - d. the same as that of a dc battery.

3. In the equivalent circuit of the synchronous generator, reactance X_s is called
 - a. stationary reactance.
 - b. steady-state reactance.
 - c. simplified reactance.
 - d. synchronous reactance.

4. The voltage regulation characteristics of a synchronous generator are
 - a. very similar to those of a single-phase transformer.
 - b. quite different from those of a single-phase transformer.
 - c. identical to those of a single-phase motor.
 - d. only useful when the generator operates without load.

Voltage Regulation Characteristics

5. In the equivalent circuit of the synchronous generator, the value of X_s , expressed in ohms,
 - a. is much smaller than the value of R_s .
 - b. is much greater than the value of R_s .
 - c. is the same value as R_s .
 - d. depends on the generator output voltage.

Frequency and Voltage Regulation

EXERCISE OBJECTIVE

When you have completed this exercise, you will be able to demonstrate frequency and voltage regulation of a synchronous generator using the Synchronous Motor/Generator module.

DISCUSSION

For a synchronous generator to operate as a power source that delivers a constant voltage at a fixed frequency, the speed of rotation and the strength of the field electromagnet must be controlled. As you saw in the previous exercise, resistive, inductive, and capacitive loads greatly affect the output voltage of a synchronous generator. Resistive loads also greatly affect the speed of a synchronous generator. However, inductive and reactive loads have little effect on the speed of rotation.

To obtain a constant output voltage and a fixed frequency from a synchronous generator under varying load conditions, the rotation speed and field current I_F must be adjusted simultaneously. In practice, automatic control systems continuously adjust the torque acting on the synchronous generator as well as the value of the field current I_F . For example, in hydroelectric systems, the torque is adjusted by changing the water turbine inlet size so as to maintain a constant speed, and thereby, a fixed frequency. The field current I_F is usually adjusted using power electronic devices so as to maintain a constant voltage. Manual adjustment of both the speed and field current at the same time is rather difficult to achieve, as you will observe in this exercise.

Procedure Summary

In the first part of the exercise, you will set up the equipment in the Workstation, connect the equipment as shown in Figure 6-9, and make the appropriate settings on the Prime Mover / Dynamometer.

In the second part of the exercise, you will set the speed of rotation and the field current of the synchronous generator so that the frequency and output voltage are equal to the nominal values. You will change the nature of the load connected to the synchronous generator to observe how this affects the frequency and output voltage.

In the third part of the exercise, you will vary both the speed of rotation and the field current of the synchronous generator so as to maintain a constant output voltage and a fixed frequency under different load conditions.

Frequency and Voltage Regulation

EQUIPMENT REQUIRED

Refer to the Equipment Utilization Chart in Appendix C to obtain the list of equipment required for this exercise.

PROCEDURE

CAUTION!

High voltages are present in this laboratory exercise! Do not make or modify any banana jack connections with the power on unless otherwise specified!

Setting up the Equipment

- 1. Install the Power Supply, Prime Mover / Dynamometer, Synchronous Motor/Generator, Resistive Load, Inductive Load, Capacitive Load, and Data Acquisition Interface (DAI) modules in the EMS workstation.

Mechanically couple the Prime Mover / Dynamometer to the Synchronous Motor/Generator.

- 2. On the Power Supply, make sure the main power switch is set to the O (off) position, and the voltage control knob is turned fully counterclockwise. Ensure the Power Supply is connected to a three-phase power source.

- 3. Ensure that the flat cable from the computer is connected to the DAI module.

Connect the LOW POWER INPUTs of the DAI and Prime Mover / Dynamometer modules to the 24 V - AC output of the Power Supply.

On the Power Supply, set the 24 V - AC power switch to the I (on) position.

- 4. Start the Metering application.

In the Metering application, open setup configuration file ACMOTOR1.CFG then select custom view 2.

- 5. Connect the equipment as shown in Figure 6-9. Open all switches on the Resistive, Inductive, and Capacitive Load modules.

On the Synchronous Motor/Generator, set the EXCITER switch to the I (close) position and the EXCITER knob to the mid position.

Frequency and Voltage Regulation

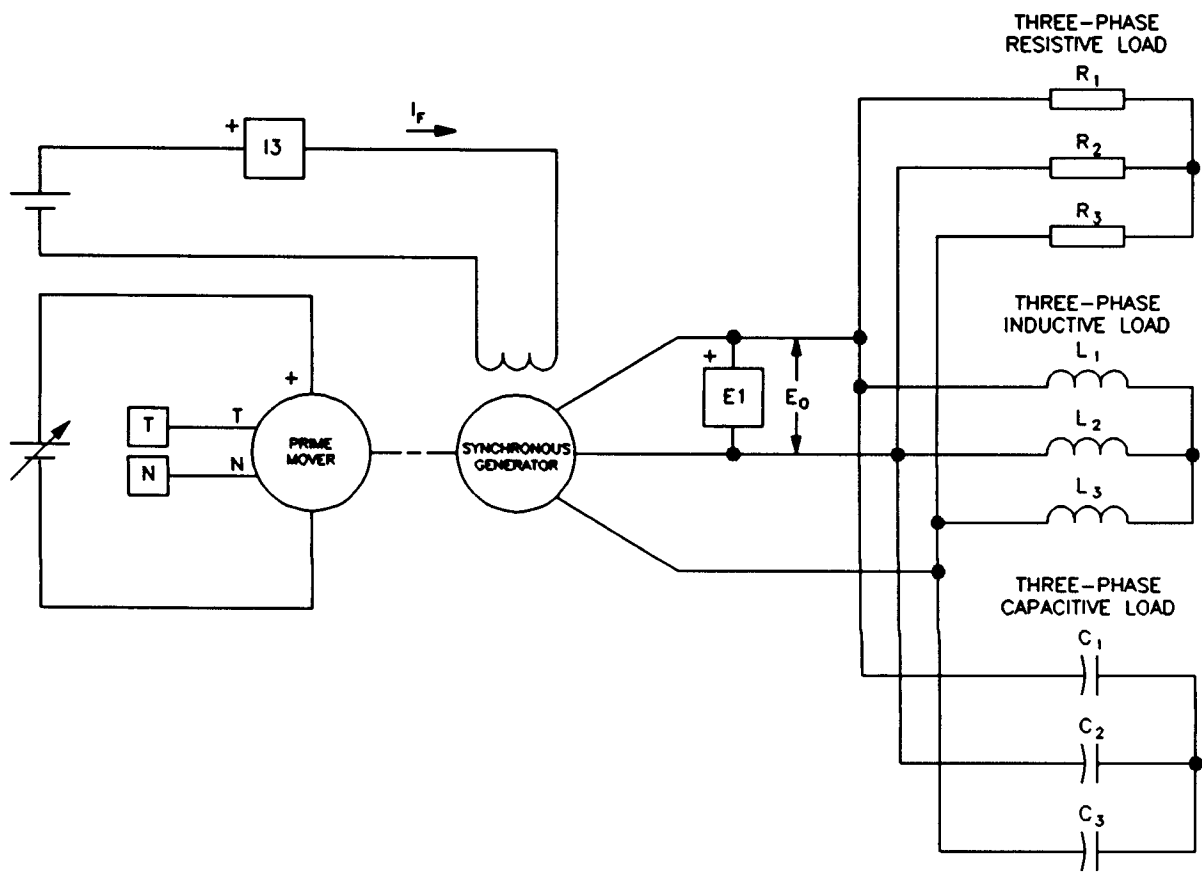

Figure 6-9. Synchronous Generator Under Load Coupled to a Prime Mover.

- 6. Set the Prime Mover / Dynamometer controls as follows:

MODE switch PRIME MOVER (P.M.)
 DISPLAY switch SPEED (N)

Note: If you are performing the exercise using LVSIM™-EMS, you can zoom in the Prime Mover / Dynamometer module before setting the controls in order to see additional front panel markings related to these controls.

Effect of the Load on the Output Voltage and the Frequency

- 7. Turn on the Power Supply and set the voltage control knob so that the Prime Mover rotates at the nominal speed of the Synchronous Motor/Generator.

Frequency and Voltage Regulation

Note: The rating of any of the Lab-Volt machines is indicated in the lower left corner of the module front panel. If you are performing the exercise using LVSIM™-EMS, you can obtain the rating of any machine by leaving the mouse pointer on the rotor of the machine of interest. Pop-up help indicating the machine rating will appear after a few seconds.

8. On the Synchronous Motor/Generator, set the EXCITER knob so that the line-to-line output voltage E_o of the synchronous generator (indicated by meter E1 in the Metering application) is equal to the nominal value.

Record the nominal output voltage E_o and frequency f (indicated by meter B in the Metering application) in the following blank spaces.

E_o (nominal) = _____ V

f (nominal) = _____ Hz

9. On the Resistive Load module, set the resistance of resistors R_1 , R_2 , and R_3 to the value indicated in the following table.

| LINE VOLTAGE | RESISTANCE OR REACTANCE |
|--------------|-------------------------|
| V ac | Ω |
| 120 | 240 |
| 220 | 880 |
| 240 | 960 |

Table 6-6. Load Value.

Record the output voltage E_o and frequency f in the following blank spaces.

E_o = _____ V (resistive load)

f = _____ Hz (resistive load)

How do the output voltage and frequency vary when a resistive load is connected to the synchronous generator output?

Frequency and Voltage Regulation

Open all switches on the Resistive Load module. Wait for the frequency and output voltage to stabilize. They should be equal to the nominal values.

10. On the Inductive Load module, set the reactance of inductors L_1 , L_2 , and L_3 to the value indicated in Table 6-6.

Record the output voltage E_o and frequency f in the following blank spaces.

$$E_o = \text{_____ V (inductive load)}$$

$$f = \text{_____ Hz (inductive load)}$$

How do the output voltage and frequency vary when an inductive load is connected to the synchronous generator output?

Open all switches on the Inductive Load module. Wait for the frequency and output voltage to stabilize. They should be equal to the nominal values.

11. On the Capacitive Load module, set the reactance of capacitors C_1 , C_2 , and C_3 to the value indicated in Table 6-6.

Record the output voltage E_o and frequency f in the following blank spaces.

$$E_o = \text{_____ V (capacitive load)}$$

$$f = \text{_____ Hz (capacitive load)}$$

How do the output voltage and frequency vary when a capacitive load is connected to the synchronous generator output?

Open all switches on the Capacitive Load module. Wait for the frequency and output voltage to stabilize. They should be equal to the nominal values.

Frequency and Voltage Regulation

12. Compare the effect of the resistive, inductive, and capacitive loads on the synchronous generator output voltage.

Compare the effect of the resistive, inductive, and capacitive loads on the frequency of the voltages produced by the synchronous generator.

Frequency and Voltage Regulation

13. On the Inductive Load module, set the reactance of inductors L_1 , L_2 , and L_3 to the value indicated in the following table.

| LINE VOLTAGE | REACTANCE OF L_1 , L_2 , AND L_3 |
|--------------|--|
| V ac | Ω |
| 120 | 600 |
| 220 | 1467 |
| 240 | 1200 |

Table 6-7. Reactance of Inductors L_1 , L_2 , and L_3 .

Readjust the voltage control knob of the Power Supply and the EXCITER knob of the Synchronous Motor/Generator so that the synchronous generator output voltage and frequency are equal to the nominal values.

14. On the Capacitive Load module, set the reactance of capacitors C_1 , C_2 , and C_3 to the value indicated in the following table.

Frequency and Voltage Regulation

| LINE VOLTAGE | REACTANCE OF C ₁ , C ₂ , AND C ₃ |
|--------------|---|
| V ac | Ω |
| 120 | 300 |
| 220 | 2200 |
| 240 | 2400 |

Table 6-8. Reactance of Capacitors C₁, C₂, and C₃.

Readjust the voltage control knob of the Power Supply and the EXCITER knob of the Synchronous Motor/Generator so that the synchronous generator output voltage and frequency are equal to the nominal values.

15. On the Resistive Load module, set the resistance of resistors R₁, R₂, and R₃ to the value indicated in the following table.

| LINE VOLTAGE | RESISTANCE OF R ₁ , R ₂ , AND R ₃ |
|--------------|--|
| V ac | Ω |
| 120 | 200 |
| 220 | 880 |
| 240 | 800 |

Table 6-9. Resistance of Resistors R₁, R₂, and R₃.

Readjust the voltage control knob of the Power Supply and the EXCITER knob of the Synchronous Motor/Generator so that the synchronous generator output voltage and frequency are equal to the nominal values.

Is it easy to rapidly readjust the synchronous generator output voltage and frequency when the load changes? Why?

16. Turn off the Power Supply and turn the voltage control knob fully counterclockwise. Set the 24 V - AC power switch to the O (off) position, and remove all leads and cables.

Frequency and Voltage Regulation

CONCLUSION

In this exercise, you observed that the output voltage and frequency of a synchronous generator change whether a resistive, inductive, or capacitive load is connected to the output. You observed that resistive loads have a greater effect on frequency than inductive and capacitive loads. You found that maintaining the frequency and output voltage to the nominal values, when the load changes, is rather difficult to achieve manually. This is because both the speed of rotation and the field current of the synchronous generator must be adjusted to correct the changes in frequency and voltage.

REVIEW QUESTIONS

1. When the load connected to a synchronous generator changes,
 - a. there is no effect on the output voltage nor the frequency.
 - b. both the output voltage and the frequency are affected.
 - c. only the output voltage is affected.
 - d. only the frequency is affected.

2. For a synchronous generator to deliver a constant output voltage at a fixed frequency,
 - a. both its speed and field current must be controlled.
 - b. only its speed must be controlled.
 - c. only its excitation current must be controlled.
 - d. the load must only be resistive.

3. Manual adjustment of the speed and field current to maintain the output voltage and frequency of a synchronous generator to the nominal values is
 - a. a simple task.
 - b. a rather difficult task.
 - c. only possible when the synchronous generator is fully loaded.
 - d. only possible when the synchronous generator is exactly at half load.

4. Inductive and capacitive loads have little effect on
 - a. both the output voltage and frequency of a synchronous generator.
 - b. the frequency of a synchronous generator.
 - c. the output voltage of a synchronous generator.
 - d. the nominal power rating of a synchronous generator.

Frequency and Voltage Regulation

5. Resistive loads have a great effect on
 - a. both the output voltage and frequency of a synchronous generator.
 - b. only the frequency of a synchronous generator.
 - c. only the output voltage of a synchronous generator.
 - d. the nominal power rating of a synchronous generator.