

# Coloring the Cartesian Sum of Graphs

Daphne Der-Fen Liu\*

Department of Mathematics  
California State University, Los Angeles  
Los Angeles, CA 90032, USA

Email: dliu@calstatela.edu

Xuding Zhu†

Department of Applied Mathematics  
National Sun Yat-sen University, Taiwan  
zhu@math.nsysu.edu.tw

Submitted: January 6, 2004

## Abstract

For graphs  $G$  and  $H$ , let  $G \oplus H$  denote their Cartesian sum. This paper investigates the chromatic number and the circular chromatic number for  $G \oplus H$ . It is proved that  $\chi(G \oplus H) \leq \max\{\lceil \chi_c(G)\chi(H) \rceil, \lceil \chi(G)\chi_c(H) \rceil\}$  holds for any  $G$  and  $H$ ; and  $\chi_c(G \oplus H) \leq \max\{\chi(H)\chi_c(G), \chi(G)\chi_c(H)\}$  holds for graphs  $G$  and  $H$  with some special values of  $\chi_c(G)$  and  $\chi_c(H)$ . These results improve previously known bounds on the corresponding coloring parameters for the Cartesian sum of graphs.

*1991 Mathematics Subject Classification.* 05C20, 05C35, 05C15

*Key words and phrases:* Cartesian sum of graphs, chromatic number, circular chromatic number, fractional chromatic number.

---

\*Supported by the National Science Foundation, USA, under grant DMS 0302456.

†Supported by the National Science Council, Taiwan, under grant NSC93-2115-M-110-004.

# 1 Introduction

There are several interesting types of graph products for which various coloring problems have been studied extensively in the literature. For instance, in [10], the author surveyed the study of the chromatic number for four kinds of graph product: Direct product (also known as the categorical product), Cartesian product, lexicographic product and strong product. Moreover, the circular chromatic number and the fractional chromatic number for these graph products have also attracted considerable attention [13, 17, 18, 19, 22, 24]. Many interesting results are known, and yet some challenging problems remain open.

A typical problem on a product of graphs is to express (or find the best bound of) a coloring parameter (such as the chromatic number or the circular chromatic number) for the product of two graphs, say  $G$  and  $H$ , in terms of the coloring parameters of  $G$  and  $H$ . For instance, the well-known Hedetniemi conjecture states: For any graph  $G$  and  $H$ ,  $\chi(G \times H) = \min\{\chi(G), \chi(H)\}$ , where  $G \times H$  is the direct product of  $G$  and  $H$ . Although the conjecture was confirmed for the cases that  $\chi(G) = \chi(H) = 3$  by Hedetniemi [7], and  $\chi(G) = \chi(H) = 4$  by El-Zahar and Sauer [4], it remains open for other cases.

In this article, we investigate the chromatic number and the circular chromatic number for a type of graph products, namely, the Cartesian sum of graphs. Suppose  $G = (V, E)$  and  $H = (V', E')$ . The *Cartesian sum* of  $G$  and  $H$ , denoted by  $G \oplus H$ , has as the vertex set  $V \times V'$ , and the edge set

$$E(G \oplus H) = \{(x, x')(y, y') : xy \in E(G) \text{ or } x'y' \in E(H)\}.$$

This notion of graph product was introduced by Ore [11] in 1962. The chromatic number for the Cartesian sum of graphs has been investigated in [2, 3, 12, 20].

For any graphs  $G$  and  $H$ , it is easy to see that  $\chi(G \oplus H) \leq \chi(G)\chi(H)$ . The bound is sharp, as  $\chi(K_n \oplus K_m) = nm$ . However, for many graphs, the value of  $\chi(G \oplus H)$  is strictly less than  $\chi(G)\chi(H)$ . Hence, one would aim at finding a better upper bound for  $\chi(G \oplus H)$  by investigating further on the structures of  $G$  and  $H$ . To this end, it is natural to consider the relations between  $\chi(G \oplus H)$  and the circular chromatic numbers of  $G$  and  $H$ .

For a graph  $G$ , the circular chromatic number is a refinement of the chromatic number. Let  $p, q$  be integers with  $p \geq 2q > 0$ . A  $(p, q)$ -coloring of a graph  $G$  is a mapping  $c : V(G) \rightarrow \{0, 1, \dots, p-1\}$  such that for any edge  $uv$  of  $G$ ,  $|c(u) - c(v)|_p \geq q$ , where  $|x - y|_n = \min\{|x - y|, n - |x - y|\}$ . The *circular chromatic number*  $\chi_c(G)$  of  $G$  is defined as

$$\chi_c(G) = \inf\{p/q : G \text{ admits a } (p, q)\text{-coloring}\}.$$

It is known that for any graph  $G$ ,

$$\chi(G) - 1 < \chi_c(G) \leq \chi(G).$$

The above is equivalent to  $\chi(G) = \lceil \chi_c(G) \rceil$ . Thus, the circular chromatic number for a graph  $G$  contains more information on the structure of  $G$  than what the chromatic number does.

Two questions about the Cartesian sum of graphs emerge naturally:

**Question 1** *What is the best upper bound for  $\chi(G \oplus H)$  in terms of  $\chi_c(G)$  and  $\chi_c(H)$ ?*

**Question 2** *What is the best upper bound for  $\chi_c(G \oplus H)$  in terms of  $\chi_c(G)$  and  $\chi_c(H)$ ?*

As  $\chi(G \oplus H) = \lceil \chi_c(G \oplus H) \rceil$ , an answer to Question 2 provides an answer to Question 1. On the other hand, an answer to Question 1 does not induce an answer to Question 2. In this article, we answer Question 1 completely, and provide partial solutions to Question 2.

A *fractional coloring* of a graph  $G$  is a mapping  $c$  from  $\mathcal{I}(G)$ , the set of all independent sets of  $G$ , to the interval  $[0, 1]$  of reals, such that  $\sum_{x \in I \in \mathcal{I}(G)} c(I) \geq 1$  holds for any  $x \in V(G)$ . The *fractional chromatic number*  $\chi_f(G)$  of  $G$  is the infimum of the value  $\sum_{I \in \mathcal{I}(G)} c(I)$  for a fractional coloring  $c$  of  $G$  (cf. [5, 8, 14, 15]). It is known [1, 21, 24] that for any graph  $G$ ,  $\chi_f(G) \leq \chi_c(G)$ .

For graphs  $G = (V, E)$  and  $H = (V', E')$ , the *lexicographic product* of  $G$  and  $H$ , denoted by  $G[H]$ , has the vertex set  $V \times V'$ , in which  $(x, x')(y, y')$  is an edge if  $[xy \in E]$  or  $[x = y \text{ and } x'y' \in E']$ . It was proved in [23] that the following holds for any  $G$  and  $H$ :

$$\chi_f(G)\chi(H) \leq \chi_c(G[H]) \leq \chi_c(G)\chi(H).$$

If it is the case that  $\chi_f(G) = \chi_c(G)$ , then we have  $\chi_c(G[H]) = \chi_c(G)\chi(H)$ . The graphs with  $\chi_f(G) = \chi_c(G)$  are called *star-extremal*. Many graphs are known to be star-extremal [6, 9] (for instance, cycles). Hence, there exist graphs  $G$  and  $H$  with  $\chi_c(G[H]) = \chi_c(G)\chi(H)$ . It is easy to see from the definition that  $G[H]$  is a spanning subgraph of  $G \oplus H$ . Therefore, if  $G$  is star-extremal, then

$$\chi_c(G \oplus H) \geq \chi_c(G)\chi(H).$$

Since the Cartesian sum is symmetric, i.e.,  $G \oplus H = H \oplus G$ , we conclude that if  $G$  and  $H$  are star-extremal, then

$$\chi_c(G \oplus H) \geq \max\{\chi_c(G)\chi(H), \chi(G)\chi_c(H)\}. \quad (1.1)$$

Consequently, if  $G$  and  $H$  are star-extremal, then

$$\chi(G \oplus H) \geq \max\{\lceil \chi_c(G)\chi(H) \rceil, \lceil \chi(G)\chi_c(H) \rceil\}. \quad (1.2)$$

In this article, we prove the following result, which answers Question 1.

**Theorem 1** *For any graphs  $G$  and  $H$ ,*

$$\chi(G \oplus H) \leq \max\{\lceil \chi_c(G)\chi(H) \rceil, \lceil \chi(G)\chi_c(H) \rceil\}.$$

*Moreover, the equality holds if  $G$  and  $H$  are star-extremal.*

For the circular chromatic number of  $G \oplus H$ , we conjecture that  $\chi_c(G \oplus H) \leq \max\{\chi_c(G)\chi(H), \chi(G)\chi_c(H)\}$  holds for all graphs  $G$  and  $H$ . If the conjecture is proved to be true, then in view of (1.1), this upper bound for  $\chi_c(G \oplus H)$  would be sharp, answering Question 2. Although it is unknown whether the conjecture holds in general, we shall prove the following result, which would give solutions to Question 2, for graphs  $G$  and  $H$  with some special values of  $\chi_c(G)$  and  $\chi_c(H)$ .

**Theorem 2** *Let  $p, q, p', q'$  be positive integers with  $p = kq + r$  and  $p' = k'q' + r'$ , where  $0 \leq r < q$  and  $0 \leq r' < q'$ . Assume  $\chi_c(G) = p/q$  and  $\chi_c(H) = p'/q'$ . Then*

$$\chi_c(G \oplus H) \leq \begin{cases} \chi_c(G)\chi(H), & \text{if } p'(p+q-1) \leq p(p'+q'-r'); \\ \chi_c(H)\chi(G), & \text{if } p(p'+q'-1) \leq p'(p+q-r). \end{cases}$$

*Moreover, the equality holds if  $G$  and  $H$  are star-extremal.*

Theorem 1 has an application. A useful tool for estimating the chromatic number of a graph  $G = (V, E)$  is to partition  $E$  into the union  $E = E_1 \cup E_2$ , and then determine (or find upper bounds for) the chromatic numbers of the spanning subgraphs  $G_1 = (V, E_1)$  and  $G_2 = (V, E_2)$ . Then we have  $\chi(G) \leq \chi(G_1)\chi(G_2)$ . Theorem 1 provides a better estimation of  $\chi(G)$  if the circular chromatic numbers of  $G_1$  and  $G_2$  are known.

**Theorem 3** *Suppose  $G = (V, E)$ . Let  $E = E_1 \cup E_2$  and  $G_i = (V, E_i)$  for  $i = 1, 2$ . Then*

$$\chi(G) \leq \chi(G_1 \oplus G_2) \leq \max\{\lceil \chi_c(G_1)\chi(G_2) \rceil, \lceil \chi(G_1)\chi_c(G_2) \rceil\}.$$

Now we define some terms that will be used in the remaining part of the paper. A *homomorphism* from a graph  $G$  to another graph  $H$  is an edge preserving mapping from  $V(G)$  to  $V(H)$ . If such a mapping exists, we say that  $G$  is *homomorphic* to  $H$ , and denote this by  $G \rightarrow H$ . It is known and easy to see that  $\chi(G) \leq n$  if and only if  $G \rightarrow K_n$ .

For any given rational  $p/q \geq 2$ , a *circular clique*  $K_{p/q}$  is the graph with the vertex set  $V(K_{p/q}) = \{0, 1, 2, \dots, p-1\}$ , in which

$$uv \in E(K_{p/q}) \text{ if and only if } |u - v|_p \geq q.$$

In the study of circular chromatic number of graphs, circular cliques play essentially the same role as cliques (complete graphs) in the study of chromatic number. It is known that  $\chi_c(K_{p/q}) = \chi_f(K_{p/q}) = p/q$ , and for any graph  $G$ ,  $\chi_c(G) \leq p/q$  if and only if  $G \rightarrow K_{p/q}$  (cf. [24]).

Note that, if it is the case that  $\chi_c(G) = \chi(G)$  or  $\chi_c(H) = \chi(H)$ , then the upper bounds in Theorems 1 and 2 coincide with the trivial bound,  $\chi_c(G \oplus H) \leq \chi(G \oplus H) \leq \chi(G)\chi(H)$ . Therefore, throughout the article, we assume  $\chi_c(G) < \chi(G)$  and  $\chi_c(H) < \chi(H)$ , when  $\chi(G \oplus H)$  or  $\chi_c(G \oplus H)$  is in consideration.

## 2 The Chromatic Number

In this section, we determine the chromatic number for the Cartesian sum of circular cliques. Consequences of this result include Theorem 1.

Let  $x$  be an integer and  $m$  a positive integer. We denote by  $[x]_m$  the remainder of  $x$  dividing by  $m$ , i.e,  $[x]_m$  is the unique integer  $x'$  such that  $0 \leq x' \leq m-1$ , and  $x - x'$  is a multiple of  $m$ .

**Lemma 1** *Let  $p, q, p', q'$  be positive integers with  $p = kq + r$  and  $p' = k'q' + r'$ , where  $1 \leq r < q$  and  $1 \leq r' < q'$ . Then*

$$\chi(K_{p/q} \oplus K_{p'/q'}) = \max\{\lceil (p/q)(k' + 1) \rceil, \lceil (p'/q')(k + 1) \rceil\}.$$

**Proof.** Let  $G = K_{p'/q'} \oplus K_{p/q}$ . Without loss of generality, we may assume that  $(p/q)(k' + 1) \geq (p'/q')(k + 1)$ . We shall prove that  $\chi(G) = n = \lceil (p/q)(k' + 1) \rceil$ . By (1.2) and since circular cliques are star-extremal, it remains to show that  $G$  is  $n$ -colorable.

Let  $V(G) = \{(i, j) : 0 \leq i \leq p' - 1, 0 \leq j \leq p - 1\}$ . For each  $(i, j) \in V(G)$ , we define a *tile*  $B_{i,j}$  as:

$$B_{i,j} = \{([i + a]_{p'}, [j + b]_p) : 0 \leq a \leq q' - 1, 0 \leq b \leq q - 1\}.$$

Intuitively, we regard  $V(G)$  as a set of  $p \times p'$  grid points embedded on a torus. We draw this torus as a  $(p \times p')$ -rectangle  $R$ , where the top and the bottom boundaries as well as the left and the right boundaries are identified. As a convention, we assume that the horizontal edge and the vertical edge of  $R$ , respectively, has lengths  $p'$  and  $p$ , as shown in Figure 1.

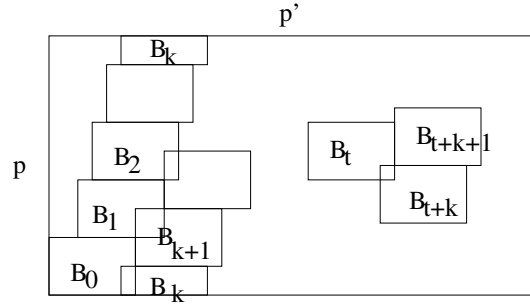

Figure 1: Covering the torus grid with rectangles

Each tile  $B_{i,j}$  is a  $q \times q'$  rectangle, and covers  $qq'$  grid points, with  $(i, j)$  as its left-bottom point on  $R$  (viewing  $(0, 0)$  as the left bottom point of  $R$ ). By definition of the Cartesian sum, each  $B_{i,j}$  is an independent set of  $G$ . To show that  $G$  is  $n$ -colorable, it suffices to prove that  $R$  can be covered by  $n$  tiles of the form  $B_{i,j}$ . Let

$$k'(q - r) = \lambda q + r^*, \text{ where } \lambda, r^* \text{ are integers with } 0 \leq r^* < q.$$

Let

$$z = \begin{cases} \lceil r^*/(q - r) \rceil, & \text{if } r^* < r; \\ 0, & \text{if } r^* \geq r. \end{cases}$$

The  $n$  tiles we use to cover  $R$  are  $B_t = B_{i_t, j_t}$ ,  $t = 0, 1, \dots, n - 1$ , where:

$$\begin{aligned} i_t &= \lceil [tq'/(k + 1)] \rceil_{p'}, & t &= 0, 1, \dots, n - 1; \\ j_t &= \begin{cases} \lceil [tq]_p, & \text{if } 0 \leq t < n - z(k + 1), \\ \lceil [tq - r^* + s(q - r)]_p, & \text{if } n - (s + 1)(k + 1) \leq t < n - s(k + 1), \\ & \text{and } 0 \leq s \leq z - 1. \end{cases} \end{aligned}$$

Note that, if  $r^* \geq r$ , then  $z = 0$ , and hence  $j_t = \lceil [tq]_p$  for all  $t$ .

Although the above formulas look complicated, the idea about the locations of these tiles is quite simple. Assume  $r^* \geq r$  (that is,  $z = 0$ ). We put the first tile,  $B_0$ ,

at the left-bottom corner of  $R$  (see Figure 1). Then we put in the remaining tiles one by one. Assume  $B_0, B_1, \dots, B_{i-1}$  are put in (winding around the torus) already. Then we put  $B_i$  exactly on the top of  $B_{i-1}$  with a “little bit” horizontal shift to the right. The shifts are carefully chosen so that the total of any  $k + 1$  consecutive shifts is equal to  $q'$ . Such a tiling process will wrap around the torus tightly, and as we will show later, the two ends (the last  $k + 1$  tiles and the first  $k + 1$  tiles) meet perfectly (without gaps).

Assume  $r^* < r$  (that is,  $z \geq 1$ ). We first use the same tiling process in the above, which, for this case, also wraps around the torus tightly, but the two ends may *not* meet perfectly. There might be gaps between the last  $k + 1$  tiles and the first  $k + 1$  tiles. To mend this, we divide the last  $z(k + 1)$  tiles into  $z$  “strips,” where each strip consists of consecutive  $k + 1$  tiles. For instance, the first strip is formed by the last  $k + 1$  tiles,  $B_{n-i}$  for  $i = 1, 2, \dots, k + 1$ , the second strip is formed by the next  $k + 1$  tiles,  $B_{n-(k+1)-i}$  for  $i = 1, 2, \dots, k + 1$ , etc. We shift each of the  $(k + 1)$  tiles in the first strip vertically downwards by  $r^*$  rows, and (if  $z \geq 2$ ) shift each tile in the  $s$ -th strip vertically downwards by  $r^* - (s - 1)(q - r)$  rows, for  $2 \leq s \leq z$ .

In the following, we claim that these tiles wrap around the torus without gaps. By looking at the first  $k + 1$  tiles,  $B_0, B_1, \dots, B_k$ , we conclude that any horizontal line of  $R$  intersects these tiles. In other words, for any  $0 \leq b \leq p - 1$ , there exists some  $a$  such that  $(a, b)$  is contained in some tile  $B_t$ .

Assume that there is a vertex, say  $(a, b)$ , which is not covered by any of the tiles. We search, from the point  $(a, b)$  on  $R$ , along the horizontal line passing through  $(a, b)$  towards the left until we find a vertex which is covered by some tile. To be precise, let  $\beta \geq 1$  be the smallest integer such that  $([a - \beta]_{p'}, b)$  is contained in some tile. Assume  $([a - \beta]_{p'}, b) \in B_t$ . As  $([a - \beta + 1]_{p'}, b) \notin B_t$ , we know that  $([a - \beta]_{p'}, b)$  is on the right boundary of  $B_t$ , i.e.,  $[a - \beta]_{p'} = [i_t + q - 1]_{p'}$ . We claim that

$$([a - \beta + 1]_{p'}, b) \in B_{t+k} \cup B_{t+k+1},$$

which is in contrary to the choice of  $\beta$ . To this end, we consider two cases.

**Case 1.**  $0 \leq t < n - (k + 1)$  We claim:

$$\{([i_t + x]_{p'}, [j_t + y]_p) : q' \leq x \leq q' + \lfloor kq'/(k + 1) \rfloor, 0 \leq y \leq q\} \subseteq B_{t+k} \cup B_{t+k+1}, \quad (2.1)$$

which implies that  $([a - \beta + 1]_{p'}, b) \in B_{t+k} \cup B_{t+k+1}$ , as  $q' \geq 2$ .

It follows from the definition that

$$\begin{aligned} [i_{t+k+1} - i_t]_{p'} &= q'; \text{ and} \\ [i_{t+k} - i_t]_{p'} &= \lceil (t + k)q'/(k + 1) \rceil - \lceil tq'/(k + 1) \rceil. \end{aligned}$$

Hence,

$$\lfloor kq'/(k+1) \rfloor \leq [i_{t+k} - i_t]_{p'} \leq q'.$$

Therefore, to verify (2.1), by noting that the bottom of  $B_{j+k+1}$  either touches or overlaps with the top of  $B_{j+k}$ , it suffices to show that the following hold:

$$[j_t - j_{t+k}]_p \leq q, \quad \text{and} \quad [j_{t+k+1} - j_t]_p \leq q. \quad (2.2)$$

Assume  $z = 0$ . Since  $p = kq + r$ , we have

$$[j_t - j_{t+k}]_p = [-kq]_p = r;$$

$$[j_{t+k+1} - j_t]_p = [(k+1)q]_p = q - r.$$

As  $r < q$  and  $q - r \leq q$ , (2.2) follows,

Assume  $z \geq 1$ . Let  $\delta = r^* - (z-1)(q-r)$ . Depending on the values of  $t$ , it can be verified that the values of  $j_t - j_{t+k}$  and  $j_{t+k+1} - j_t$  have the following possibilities:

$$j_t - j_{t+k} \in \{-kq, -(kq - (q-r)), -(kq - \delta)\}$$

and

$$j_{t+k+1} - j_t \in \{(k+1)q, (k+1)q - (q-r), (k+1)q - \delta\}.$$

Again, because  $[-kq]_p = r$ ,  $[(k+1)q]_p = q - r$ , and  $\delta \leq q - r$ , we conclude that (2.2) holds for all the above possibilities. This completes the proof of Case 1.

Intuitively, the argument for Case 1 shows that the tiles,  $B_0, B_1, \dots, B_{n-(k+1)}$ , wrap around part of the torus *tightly*, i.e., the right side of each tile  $B_t$ , for  $t \leq n - (k+1)$ , is covered by or touch with the left sides of tiles  $B_{t+k}$  and  $B_{t+k+1}$  (see Figure 1).

**Case 2.**  $n - (k+1) \leq t < n$  Suppose  $t = n - (k+1) + m$  for some  $0 \leq m \leq k$ .

First we assume that  $r^* < r$ . Then, by definition and some calculation, we have  $n = (k'+1)k + \lceil (k'+1)r/q \rceil = (k+1)(k'+1) - \lambda$ . Therefore,

$$\begin{aligned} j_{n-(k+1)} &= [(n - (k+1))q - r^*]_p \\ &= [k'(k+1) - \lambda]q - r^*]_p \\ &= [k'(kq + r)]_p \\ &= 0 = j_0. \end{aligned}$$

Thus, for each  $0 \leq l \leq k$ , we have  $j_{n-(k+1)+l} = j_l = lq$ . In particular,  $j_t = mq$ , i.e.,  $B_t$  and  $B_m$  are on the same horizontal level. We shall show that  $([a - \beta + 1]_{p'}, b) \in B_m$ . This amounts to prove that

$$[i_m - i_{n-(k+1)+m}]_{p'} \leq q'. \quad (2.3)$$



That is,

$$\lceil [mq'/(k+1)] - \lceil (n - (k+1) + m)q'/(k+1) \rceil \rceil_{p'} \leq q'.$$

Since  $\lceil [mq'/(k+1)] < \lceil (n - (k+1) + m)q'/(k+1) \rceil < p' + \lceil [mq'/(k+1)] \rceil$ , this is equivalent to

$$p' + \lceil [mq'/(k+1)] \rceil - \lceil (n - (k+1) + m)q'/(k+1) \rceil \leq q'.$$

which holds if and only if

$$p' \leq nq'/(k+1).$$

This is true since  $n \geq (p/q)(k'+1) \geq (p'/q')(k+1)$ .

Next we assume that  $r^* \geq r$ . We shall prove that if  $1 \leq m \leq k$ , then  $([a - \beta + 1]_{p'}, b) \in B_{m-1} \cup B_m$ ; and if  $m = 0$ , then  $([a - \beta + 1]_{p'}, b) \in B_{n-1} \cup B_0$ .

If  $m \geq 1$ , then  $j_{n-(k+1)+m} = \lceil (n - (k+1) + m)q \rceil_p = r^* + (m-1)q$ . Hence  $j_{m-1} \leq j_t \leq j_m$ . To prove that  $([a - \beta + 1]_{p'}, b) \in B_{m-1} \cup B_m$ , it suffices to show that the right side of the rectangle  $B_t$  touches or overlaps with the left sides of  $B_m$  and  $B_{m-1}$ . This is equivalent to show that  $\lceil i_{m-1} - i_t \rceil_{p'} \leq q'$  and  $\lceil i_m - i_t \rceil_{p'} \leq q'$ . As  $i_t - p' \leq i_{m-1} \leq i_m < i_t$ , it suffices to show that  $\lceil i_m - i_t \rceil_{p'} = \lceil i_m - i_{n-(k+1)+m} \rceil_{p'} \leq q'$ , which is (2.3), and has been verified in the above.

Assume  $m = 0$ . It amounts to prove that the right side of  $B_{n-(k+1)}$  touches or overlaps with the left sides of  $B_0$  and  $B_{n-1}$ . This is true since, by a special case of (2.3), we have  $\lceil i_0 - i_{n-(k+1)} \rceil_{p'} \leq q'$ , and similar to the argument used in Case 1, we have  $\lceil i_{n-1} - i_{n-(k+1)} \rceil_{p'} \leq q'$ .  $\blacksquare$

**Proof of Theorem 1)** Assume  $\chi_c(G) = p/q$  and  $\chi_c(H) = p'/q'$ . Then there is a homomorphism  $f$  from  $G$  to  $K_{p/q}$ , and a homomorphism  $g$  from  $H$  to  $K_{p'/q'}$ . It is easy to check that the mapping  $\phi(x, y) = (f(x), g(y))$  is a homomorphism from  $G \oplus H$  to  $K_{p/q} \oplus K_{p'/q'}$ . Therefore  $\chi(G \oplus H) \leq \chi(K_{p/q} \oplus K_{p'/q'})$ . The conclusion then follows from Lemma 1. The moreover part follows from (1.2).  $\blacksquare$

The next result follows from Theorem 1 and (1.2).

**Corollary 1** *For any two graphs  $G$  and  $H$ , if  $\chi_c(G)\chi(H) \geq \chi(G)\chi_c(H)$  and  $G$  is star-extremal, then*

$$\chi(G \oplus H) = \lceil \chi_c(G)\chi(H) \rceil.$$

Čížek and Klavžar [3] showed that if  $G$  and  $H$  are vertex-critical and are not complete graphs, then  $\chi(G \oplus H) < \chi(G)\chi(H)$ . It is known [16] that if  $G$  is vertex-critical with  $\chi(G) = k$  and with girth (length of a shortest cycle) at least  $k$ , then  $\chi_c(G) \leq k - (1/2)$ . Hence, by Theorem 1, we have

**Corollary 2** *Let  $G$  be a vertex-critical graph with  $\chi(G) = k$  and girth at least  $k$ . If  $H$  is a graph such that  $\chi_c(G)\chi(H) \geq \chi(G)\chi_c(H)$ , then*

$$\chi(G \oplus H) \leq \lceil (k - 1/2)\chi(H) \rceil.$$

### 3 The Circular Chromatic Number

Theorem 1 gives the best upper bound for the chromatic number of the Cartesian sum  $G \oplus H$  in terms of  $\chi_c(G)$  and  $\chi_c(H)$ . However, the best upper bound for the circular chromatic number of  $G \oplus H$  in terms of  $\chi_c(G)$  and  $\chi_c(H)$  for all graphs  $G$  and  $H$  remains unknown. We propose:

**Conjecture 1** *For any graphs  $G$  and  $H$ ,*

$$\chi_c(G \oplus H) \leq \max\{\chi_c(G)\chi(H), \chi(G)\chi_c(H)\}.$$

As we pointed out earlier, if Conjecture 1 is true, then this upper bound would be the best. Theorem 2 confirms the conjecture for some special cases.

To prove Theorem 2, we make use of the following result.

**Lemma 2** *Let  $p, q, p', q'$  be positive integers with  $p = kq + r$  and  $p' = k'q' + r'$ , where  $1 \leq r < q$  and  $1 \leq r' < q'$ . Then*

$$\chi_c(K_{p/q} \oplus K_{p'/q'}) = \begin{cases} (p/q)(k' + 1), & \text{if } p'(p + q - 1) \leq p(p' + q' - r'); \\ (p'/q')(k + 1), & \text{if } p(p' + q' - 1) \leq p'(p + q - r). \end{cases}$$

**Proof.** By (1.1),  $\chi_c(K_{p/q} \oplus K_{p'/q'}) \geq \max\{(p/q)(k' + 1), (p'/q')(k + 1)/q'\}$ . Thus, we only need to verify the other direction of the inequality.

By symmetry, it is enough to verify the second case in Lemma 2. Assume  $p(p' + q' - 1) \leq p'(p + q - r)$ . Observe that  $(p'/q')(k + 1) \geq (p/q)(k' + 1)$  is equivalent to  $p(p' + q' - r') \leq p'(p + q - r)$ . So  $p(p' + q' - 1) \leq p'(p + q - r)$  implies that

$$(p'/q')(k + 1) \geq (p/q)(k' + 1).$$

Let  $G = K_{p'/q'} \oplus K_{p/q}$ . It suffices to find an  $(n, q')$ -coloring for  $G$ , where  $n = p'(k + 1)$ . Before defining such a coloring, we need a few more notations. Divide  $p' + q' - 1$  into  $q$  numbers *almost evenly*, by letting

$$t_i = \lceil i(p' + q' - 1)/q \rceil - \lceil (i - 1)(p' + q' - 1)/q \rceil, \quad i = 1, 2, \dots, q.$$

Then,  $t_1 + t_2 + \cdots + t_l = \lceil l(p' + q' - 1)/q \rceil$  for any  $1 \leq l \leq q$ .

Define  $y_j$  for  $j = 0, 1, \dots, p - 1$  by:

$$\begin{aligned} y_0 &= 0; \text{ and} \\ y_j &= y_{j-1} + t_b, \text{ if } j \geq 1, \text{ and } j = sq + b, \text{ where } s, b \text{ are integers and } 1 \leq b \leq q. \end{aligned}$$

For any integers  $z, w$ , the *interval from  $z$  to  $w$  modular  $n$* , denoted by  $[z, w]_n$ , is the set of consecutive integers from  $[z]_n$  to  $[w]_n$ , with calculation taken under modulo  $n$ . For instance,  $[2, 5]_7 = \{2, 3, 4, 5\}$ ,  $[5, 2]_7 = \{5, 6, 0, 1, 2\}$  and  $[13, 8]_7 = \{6, 0, 1\}$ .

For each  $0 \leq j \leq p - 1$ , let  $I_j$  be the interval:

$$I_j = [y_j, y_j + p' - 1]_n.$$

For  $0 \leq x \leq n - 1$ , let:

$$A_x = \{(i, j) : i = [x]_{p'} \text{ and } x \in I_j\}.$$

The coloring  $f$  is defined by  $f(i, j) = x$ , if  $(i, j) \in A_x$ . It remains to show that  $f$  is an  $(n, q')$ -coloring for  $G$ . Suppose  $(i, j)(i', j')$  is an edge in  $G$ . Let  $f(i, j) = x$  and  $f(i', j') = y$ . We need to prove that  $|x - y|_n \geq q'$ .

By definition,  $ii' \in E(K_{p', q'})$  or  $jj' \in E(K_{p, q})$ . If  $ii' \in E(K_{p', q'})$ , then  $|i - i'|_{p'} \geq q'$ . By definition,  $i = [x]_{p'}$  and  $i' = [y]_{p'}$ , implying  $|x - y|_n \geq q'$  (since  $n = p'(k + 1)$ ).

Assume  $jj' \in E(K_{p, q})$ . By definition,  $x \in I_j$ ,  $y \in I_{j'}$  and  $|j - j'|_p \geq q$ . Hence,

$$y \in I_{j+q} \cup I_{j+q+1} \cup \cdots \cup I_{j+p-q},$$

with the sub-indices taken under modulo  $p$ . This implies,

$$y \in [y_{j+q}, y_{j+p-q} + p' - 1]_n.$$

Let  $j = sq + b$  for some  $1 \leq b \leq q$ . Then, we have

$$x \in I_j = [y_j, y_j + p' - 1]_n,$$

where  $y_j = s(p' + q' - 1) + t_1 + t_2 + \cdots + t_b$ .

Hence, to show that  $|x - y|_n \geq q'$ , it suffices to verify the following:

$$q' \leq |y_{j+q} - (y_j + p' - 1)| \leq n - q' \tag{3.1}$$

$$q' \leq |(y_{j+p-q} + p' - 1) - y_j| \leq n - q'. \tag{3.2}$$

Since  $y_{j+q} = y_j + p' + q' - 1$ , so  $|y_{j+q} - (y_j + p' - 1)| = q'$ . Thus, (3.1) holds. As  $j + p - q = j + (k - 1)q + r$ , we have

$$y_{j+p-q} = y_j + (k - 1)(p' + q' - 1) + t_{b+1} + t_{b+2} + \cdots + t_{b+r}, \text{ implying}$$

$$(y_{j+p-q} + p' - 1) - y_j = k(p' + q' - 1) + t_{b+1} + \cdots + t_{b+r} - q'.$$

Since  $k \geq 2$ , we have  $(y_{j+p-q} + p' - 1) - y_j \geq q'$ . It remains to show that  $(y_{j+p-q} + p' - 1) - y_j \leq n' - q'$ . As  $t_{b+1} + \cdots + t_{b+r} \leq \lceil (r/q)(p' + q' - 1) \rceil$ , to prove (3.2), it suffices to show that

$$k(p' + q' - 1) + \lceil (r/q)(p' + q' - 1) \rceil \leq n.$$

which is equivalent to

$$k(p' + q' - 1) + (r/q)(p' + q' - 1) \leq n.$$

The above is true by the assumption that  $p(p' + q' - 1) \leq p'(p + q - r)$ . This completes the proof.  $\blacksquare$

**Proof of Theorem 2)** Suppose  $\chi_c(G) = p/q$  and  $\chi_c(H) = p'/q'$ . Then  $G$  admits a homomorphism to  $K_{p/q}$ , and  $H$  admits a homomorphism to  $K_{p'/q'}$ , which implies that  $G \oplus H$  admits a homomorphism to  $K_{p/q} \oplus K_{p'/q'}$ . Therefore,

$$\chi_c(G \oplus H) \leq \chi_c(K_{p/q} \oplus K_{p'/q'}).$$

The conclusion of Theorem 2 then follows from Lemma 2. The moreover part follows from (1.1).  $\blacksquare$

**Corollary 3** *If  $\chi_c(G) = p/q$ ,  $[p]_q = 1$  and  $\chi_c(G)\chi(H) \geq \chi(G)\chi_c(H)$  then*

$$\chi_c(G \oplus H) \leq \chi_c(G)\chi(H).$$

*Moreover, the equality holds if  $G$  is star-extremal.*

**Proof.** Assume  $p = kq + 1$  and  $\chi_c(H) = p'/q'$  where  $p' = k'q' + r'$ . The hypothesis  $\chi_c(G)\chi(H) \geq \chi(G)\chi_c(H)$  is equivalent to  $p'(p + q - 1) \leq p(p' + q' - r')$ . The moreover part follows from (1.1).  $\blacksquare$

Another consequence of Theorem 2 is the case when  $r = r' = 1$ , for which, by Corollary 3, the value of  $\chi_c(K_{kq+1} \oplus K_{k'q'+1})$  can be completely determined, confirming Conjecture 1 for this case.

**Corollary 4** *For any graphs  $G$  and  $H$  with  $\chi_c(G) = p/q$  and  $\chi_c(H) = p'/q'$ . If  $[p]_q = 1$  and  $[p']_{q'} = 1$ , then*

$$\chi_c(G \oplus H) \leq \max\{\chi_c(G)\chi(H), \chi(G)\chi_c(H)\}.$$

*Moreover, the equality holds if  $G$  and  $H$  are star-extremal.*

In searching of the graphs with  $\chi(G \oplus H) < \chi(G)\chi(H)$ , Borowiecki [2] pointed out that  $\chi(C_5 \oplus C_5) \leq 8$ . By Corollary 4 and the fact that  $\chi_c(C_{2k+1}) = \chi_f(C_{2k+1}) = 2 + (1/k)$  for all odd cycles, we obtain a stronger and more general result:

**Example 1** *For any  $n \geq k \geq 2$ ,  $\chi_c(C_{2n+1} \oplus C_{2k+1}) = 6 + (3/k)$ .*

## Acknowledgment

The authors wish to thank Claude Tardif, whose comments on a problem related to the chromatic number of the Cartesian sum of odd cycles initiated the study of this paper. The coloring used in the proof of Theorem 1 was inspired by several examples of “covering the dots on a donut” discovered by Jessica Ma (11-year-old).

## References

- [1] J. A. Bondy and P. Hell, *A note on the star chromatic number*, J. Graph Theory, 14 (1990), 479 – 482.
- [2] M. Borowiecki, *On chromatic number of products of two graphs*, Colloq. Math., 25 (1972), 49 – 52.
- [3] N. Čížek and S. Klavžar, *On the chromatic number of the lexicographic product and the Cartesian sum of graphs*, Discrete Math., 134 (1994), 17 – 24.
- [4] M. El-Zahar and N. Sauer, *The chromatic number of the product of two 4-chromatic graphs is 4*, Combinatorica, 5 (1985), 121 – 126.
- [5] D. Fisher, *Fractional coloring with large denominators*, J. Graph Theory, 20 (1995) 403 – 409.
- [6] G. Gao and X. Zhu, *Star-extremal graphs and the lexicographic product*, Disc. Math., 152 (1996), 147 – 156.

- [7] S. T. Hedetniemi, *Homomorphisms of graphs and automata*, Technical Report 03105-44-T, University of Michigan, 1966.
- [8] I. Leader, *The fractional chromatic number of infinite graphs*, J. Graph Theory, 20 (1995), 411 – 417.
- [9] K.-W. Lih, D. Liu and X. Zhu, *Star-extremal circulant graphs*, SIAM J. Disc. Math., 12 (1999), 491 – 499.
- [10] S. Klavžar, *Coloring graph products - A survey*, Disc. Math., 155 (1996), 135—145.
- [11] O. Ore, *Theory of Graphs*, American Mathematical Society, 1962.
- [12] V. Puš, *Chromatic number of products of graphs*, Technical Report 88-85, Charles University, Prague, 1988.
- [13] N. Sauer, *Hedetniemi's conjecture – a survey*, Discrete Math., 229 (2001), 261 – 292.
- [14] E. Scheinerman and D. Ullman, *Fractional Graph Theory*, Wiley-Interscience Series in Discrete Mathematics and Optimization, 1997.
- [15] S. H. Scott, *Multiple node colourings of finite graphs*, Doctoral dissertation, University of Reading, England, March 1975.
- [16] E. Steffen and X. Zhu, *On the star chromatic numbers of graphs*, Combinatorica, 16 (1996), 439 – 448.
- [17] C. Tardif, *The chromatic number of the product of two graphs is at least half the minimum of the fractional chromatic numbers of the factors*, Comment. Math. Univ. Carolin., 42 (2001), 353 – 355.
- [18] C. Tardif, *Chromatic numbers of products of tournaments: fractional aspects of Hedetniemi's conjecture*, Graphs, morphisms and statistical physics, DIMACS Ser. Discrete Math. Theoret. Comput. Sci., 63 (2004), 171 – 175.
- [19] C. Tardif, *Multilicative graphs and semi-lattice endmorphisms in the category of graphs*, preprint, 2003.
- [20] K. W. Yang, *Chromatic number of Cartesian sum of two graphs*, Proc. Amer. Math. Soc., 19 (1968), 617 – 618.
- [21] A. Vince, *Star chromatic number*, J. Graph Theory, 12 (1988), 551 – 559.
- [22] X. Zhu, *The fractional chromatic number of the direct product of graphs*, Glasgow Mathematical Journal, 44 (2002), 103 – 115.

- [23] X. Zhu, *Star chromatic numbers and products of graphs*, J. Graph Theory, 16 (1992), 557–569.
- [24] X. Zhu, *Circular chromatic number: A survey*, Disc. Math., 229 (2001), 371 – 410.
- [25] X. Zhu, *A survey on Hedetniemi’s conjecture*, Taiwanese J. Math., 2 (1998), 1–24.