



# BAJA SAE

## OFF-ROAD VEHICLE DESIGN AND MANUFACTURING

**Team Members:** Sergio Perez, Hector Palapa, Darren Crawford, Raymond Farias, Jocylene Arevalo, Ronald Carranza, Shahroz Zaheer

**Faculty Advisor:** Dr. John Christopher Bachman

**Liaison:** Society of Automotive Engineers

Department(s) of Mechanical Engineering

College of Engineering, Computer Science, and Technology

California State University, Los Angeles



### PROJECT BACKGROUND

### REQUIREMENTS

Baja SAE is an intercollegiate competition where teams build and race an off-road vehicle against schools from across the globe. Traditionally the high performing vehicles are two-wheel drive. However, the most recent revision to the rules requires the vehicle to provide power to all four wheels. Implementing the four-wheel drive system will have a drastic impact on the steering and drivability of the vehicle. The Baja SAE senior design team designed and built a 4-Wheel drive off-road vehicle that can navigate the SAE maneuvering course with similar performance to that of the traditional two-wheel drive vehicles.

Requirement	Derived From	Verification Method	Verification Activity
1 Drivetrain shall provide power to all four wheels	BAJA SAE Rules	Testing	Field Testing. Vehicle in air and verification of 4 wheels receiving power
2 Steering will use Ackerman Geometry obtain a turning radius of < 7ft.	Steering System Goal	Analysis	SolidWorks CAD, Measurement
3 Handbrake must lock up either of the front wheels (to the driver's discretion) while the car is in motion	Brake System Goal	Testing	Field testing on dirt with fully assembled vehicle
4 Brakes system must be able to lock/slide all four wheels under asphalt, dirt, and loose gravel conditions	BAJA SAE Rules	Modeling	Solidworks CAD
5 Hubs should be able to withstand minimum cornering load/force of 80lbf on top spoke and 60lbf on bottom spoke.	Drivetrain System Goal	Analysis	Solidworks FEA
6 Front suspension geometry shall maintain dynamic negative wheel camber and static wheel camber of -1.0-1.5 degrees	Suspension System Goal	Analysis	Vsusp software/Solid works CAD
7 Rear suspension shall maintain neutral toe angle when static and a negative wheel toe angle when dynamic. (>0 deg toe out -)	Suspension System Goal	Analysis	Solidworks CAD
8 Rear suspension geometry shall maintain a dynamic negative wheel camber angle and static neutral wheel camber angle (<0 deg angle into frame -)	Suspension System Goal	Analysis	Solid works CAD
9 Data acquisition (DAQ) systems shall provide the other subsections with data via data logging or telemetry	Electrical System Goal	Testing	Testing if DAQ system powers on and gathers data during field testing

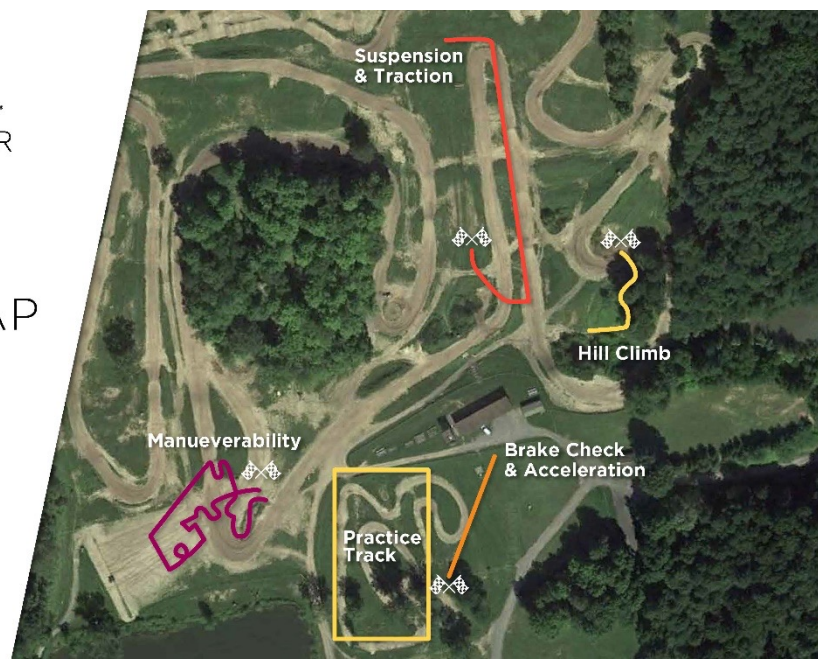
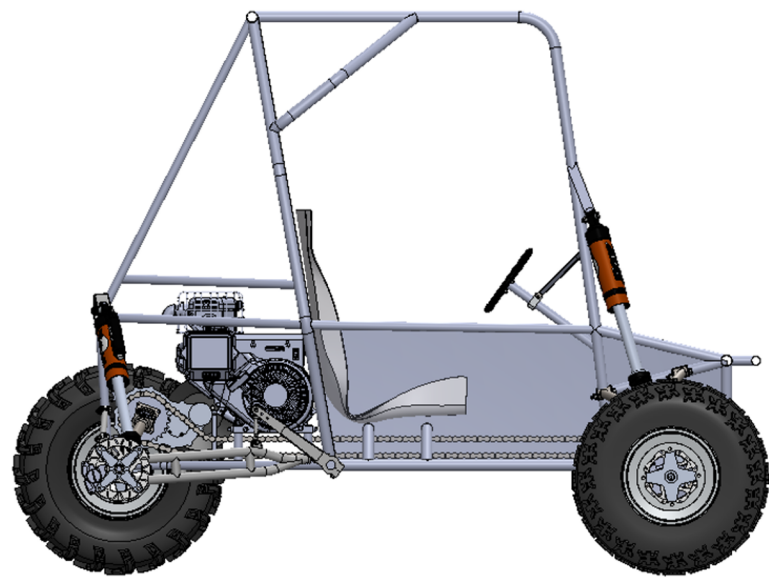

### DRIVETRAIN

### STEERING

### ELECTRONICS

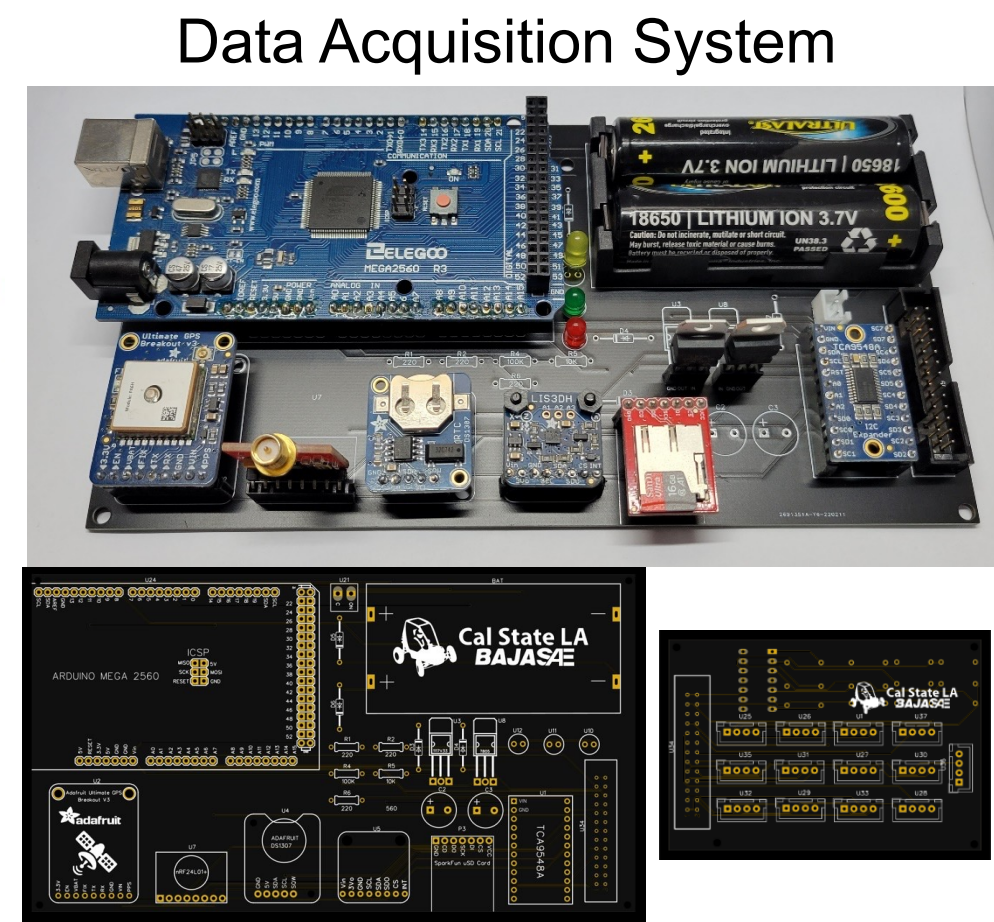
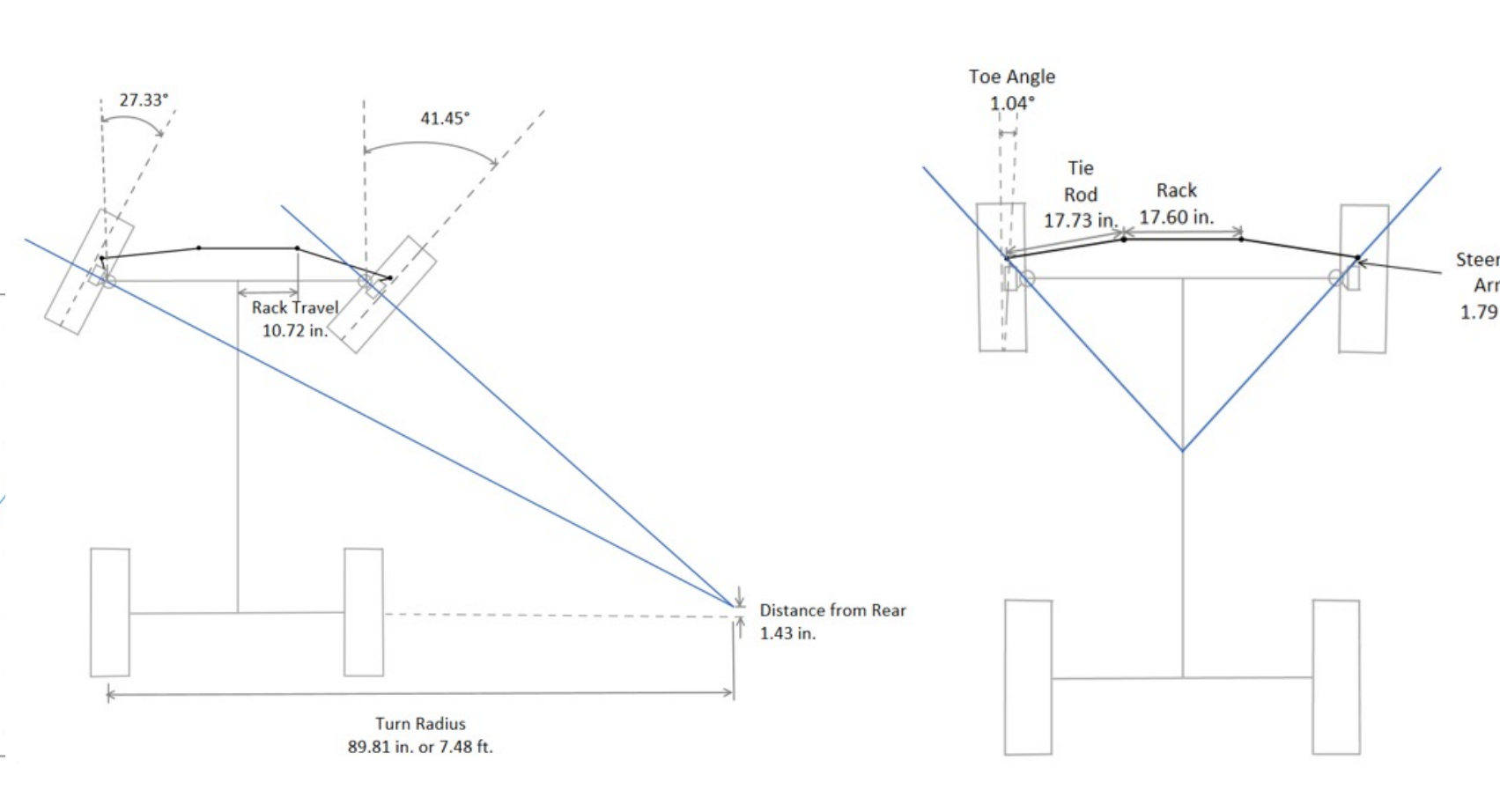
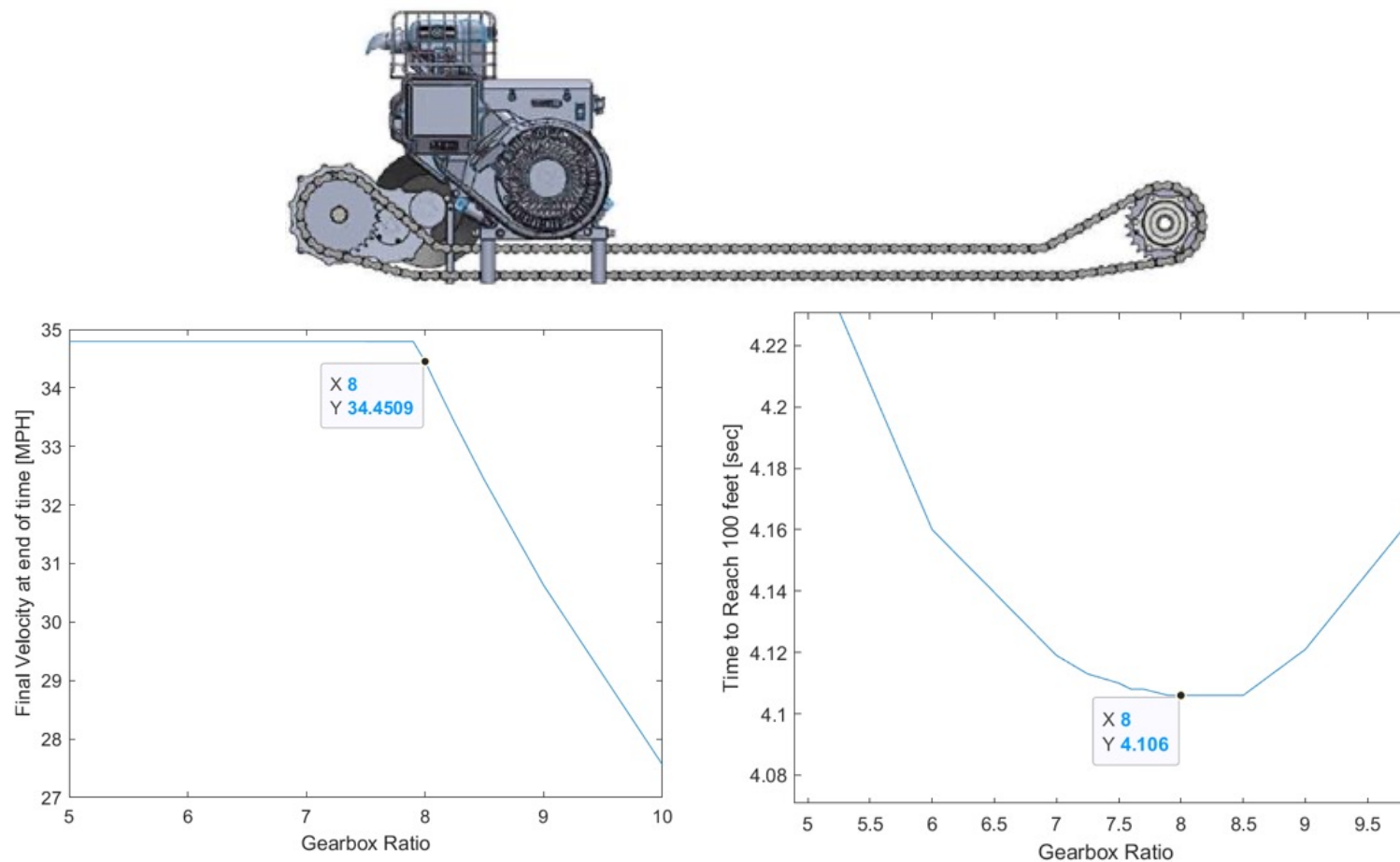

The design process for the overall vehicle began with addressing how to get power to the front two wheels. The drivetrain team entered the research phase by selecting three different solutions, a hydraulic system, a driveshaft system, and a chain drive system. The chain drive system was selected through a trade study of the three systems. A straight-line simulation of the vehicle was created using the added 4-Wheel drive components. This simulation would dictate many of the major requirements for the entire vehicle because it would fix the gear ratio. The simulation showed that at a gear ratio of 8:1, the top speed would be limited by engine power and not by RPMs, and the vehicle would achieve a 100ft acceleration time of 4.106 seconds.

The design of the steering system encountered many packaging and system integration hurdles. The packaging of the front differential, CV axle, brake, and gas pedal made achieving the optimal geometry challenging. The minimum turning radius achieved was 7.48ft after considering all these subsystems. The combined Ackerman geometry and turning radius should aid in the vehicle's maneuverability.

The electrical system developed a DAQ system to collect steering and handling data. A steering sensor is used to facilitate measuring the steering angle, which measures the wheel angle and rate of turn. Pressure transducers combined with accelerometers and a GPS module are used to characterize the new handbrake system and determine if the handbrake improves the vehicle's maneuverability.

### BRAKE BIAS

### SUSPENSION

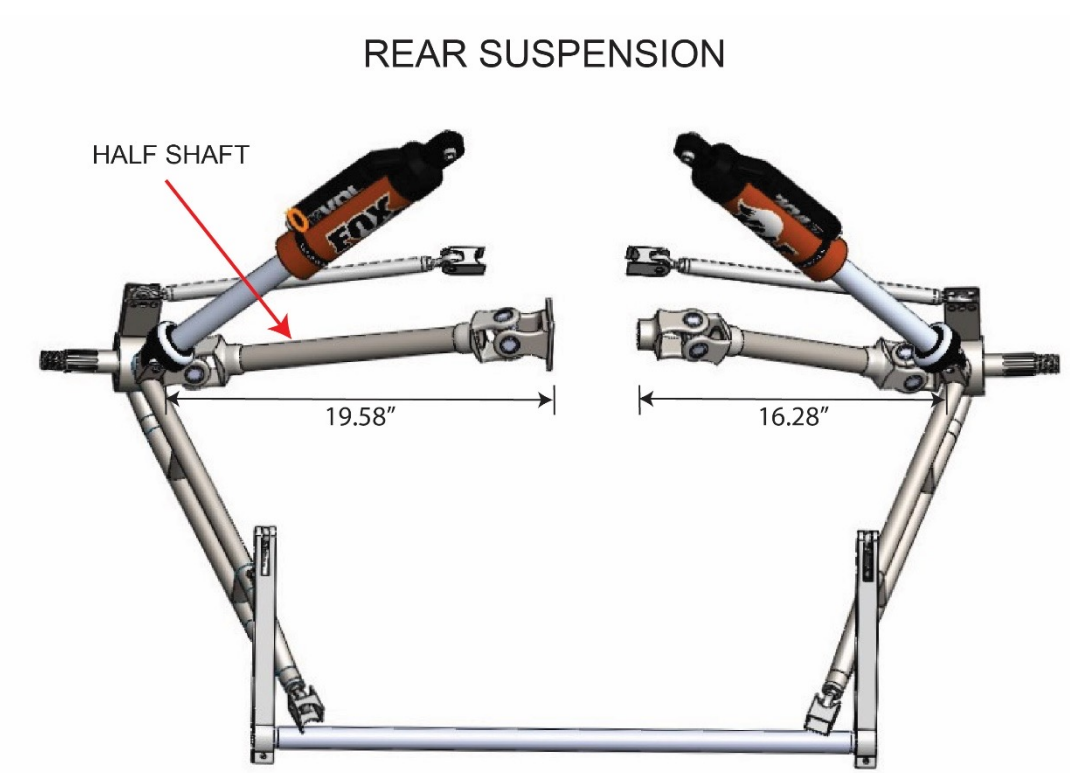
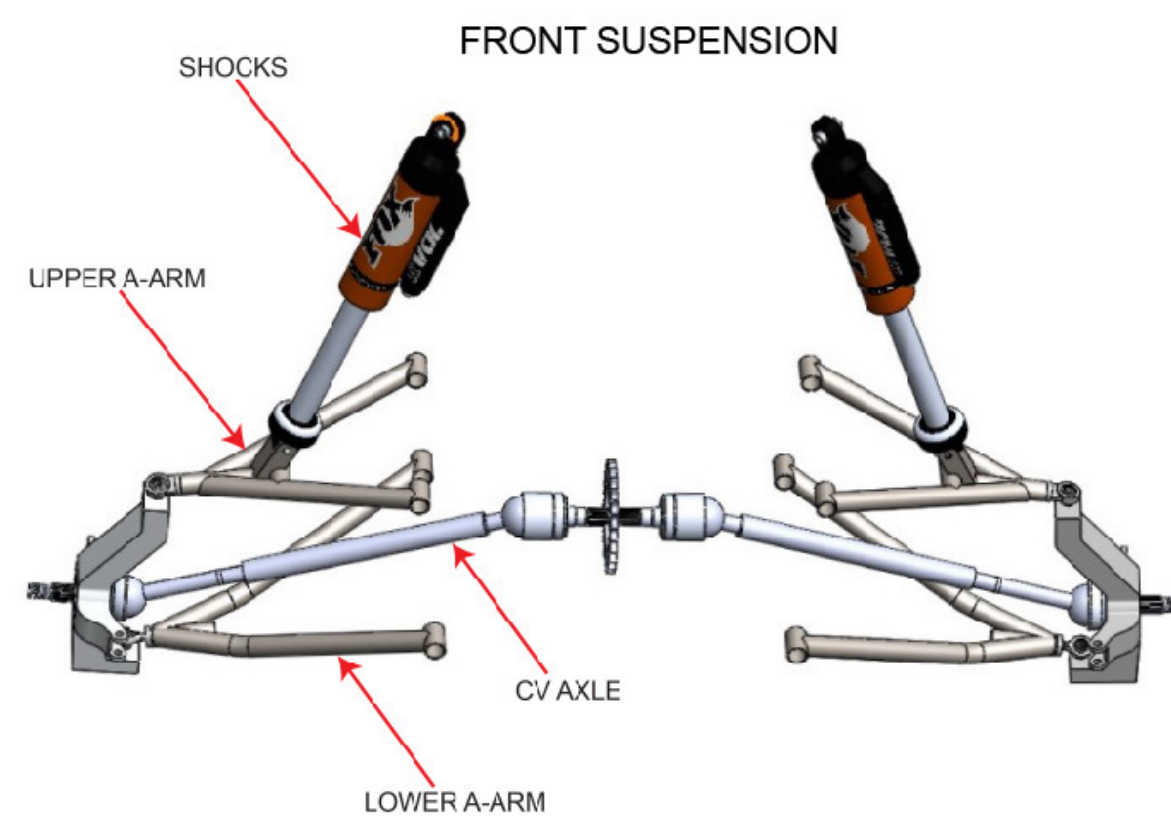
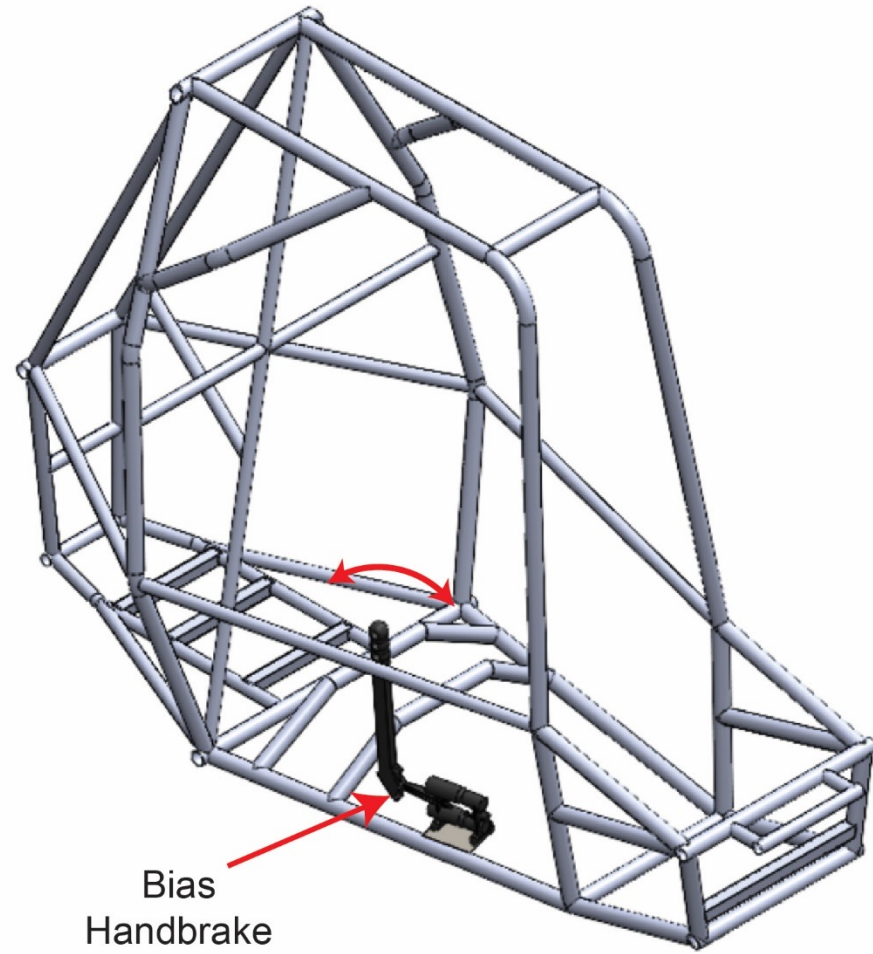
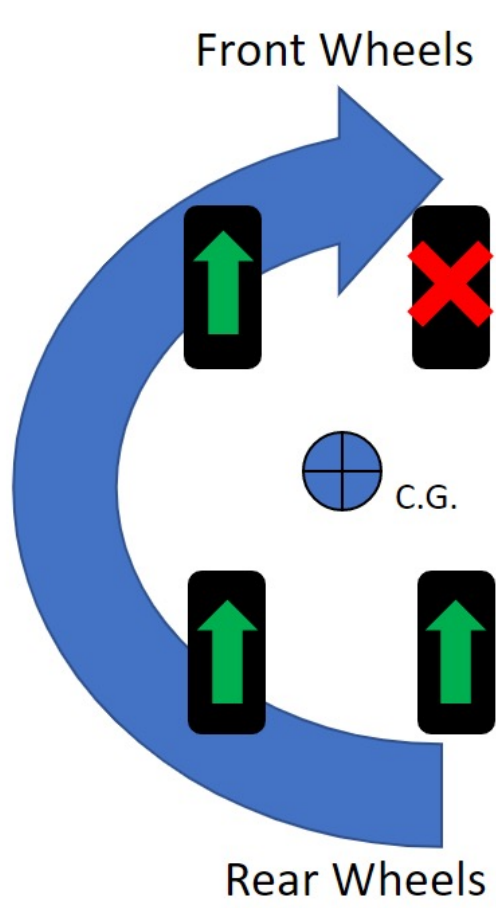

To improve the steering and handling of the vehicle, a brake bias system was added. The dual cylinder handbrake allows for application of the brakes to either of the front wheels in order to pivot the car about that wheel in a tight turn.

The front and rear suspension had major modifications due to the 4-wheel drive system. The shock placement had to be moved from the bottom A-arm to the top A-arm for the front suspension to make space for the new axles that provide power to the front two wheels. The rear suspension had to accommodate the rear sprocket attached to the gearbox; this caused the half shafts to be asymmetrical to maintain the correct kinematics without collision.

### CONCLUSION



The vehicle's overall design and decision-making focused on maintaining the vehicle's handling and maneuverability while driving all four wheels. The system integration and packaging of components presented many obstacles. The chain drive for the four-wheel drive system required every subsystem to consider its design to maintain the steering and handling we achieve in our two-wheel drive vehicles. The steering system had to package its rack and pinion next to the front differential while maintaining a specific turning radius and Ackerman geometry. The suspension system had to integrate CV axles into the front suspension; the rear suspension had to maintain geometry while having asymmetrical half-shafts. The brake system developed an entirely new system that will bias the front wheels to make hairpin turns. The electrical system will provide data to each subsystem so they can validate their designs. This Baja SAE team has developed and built a first of its kind four-wheel drive vehicle.

