

Auto-Leveling Tool



Team Members: Juan Garibay, Alec Garcia, Karen Velasquez, Vicki Wang, Jose Rochin

Faculty Advisor: Everardo Hernandez

Boeing Liaison: Teofilo El Masri, Jacqueline Martinez, Jonathan Fish

Department of Mechanical Engineering

College of Engineering, Computer Science, and Technology

California State University, Los Angeles



Background

Objective

Boeing currently has a stand that is manually adjusted and aligned to support a deployed appendage. Team 29 is tasked with developing an automated design concept and providing a prototype to demonstrate proof of concept. This portable robotic stand system must be designed to incorporate properties of configuration and self-adjust to level a 3"x5" plate at the very top of the Automated Self-Leveling Tool to the 3"x5" plate at the bottom of 150lb appendage and support that weight.

Requirements

- R1: Meets clean room environment requirements
- R2: Shall not use prohibited materials or emit radio frequency radiation
- R3: Shall be portable and hold a 150lb appendage and have a footprint within 100" and reach 45 degrees.
- R4: Shall maintain a maximum displacement of 0.005" at the mating interface
- R5: Shall offload appendage per operator load input within 0.50 lb.
- R6: Shall read weight of appendage being offloaded
- R7: Appendage center of gravity shall remain within footprint of tool
- R8: The prototype shall meet all the requirements above to display proof of concept.
- R9: Shall read 3"x5" surface and self-adjust to be parallel to maintain displacement requirements at the mating surface
- R10: System shall be sufficiently stiff to avoid displacement changes during load transfer

Design Approach

Overall Design

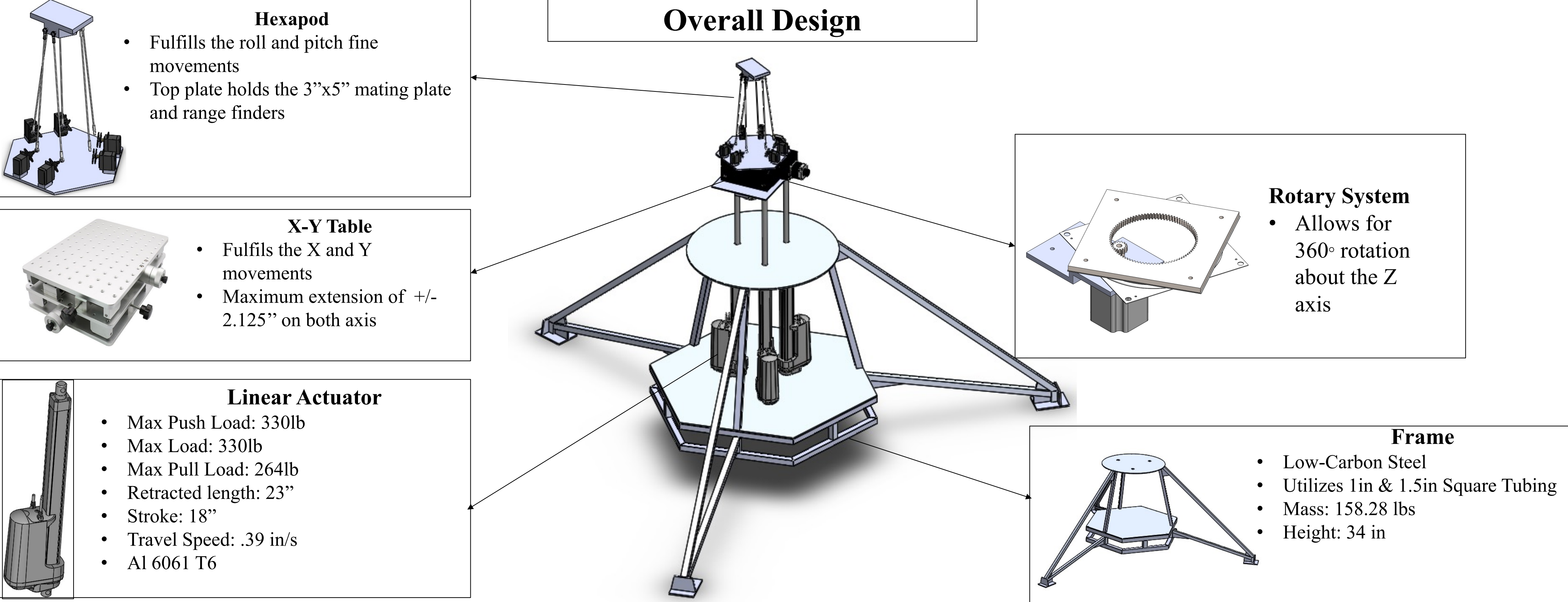

Analysis

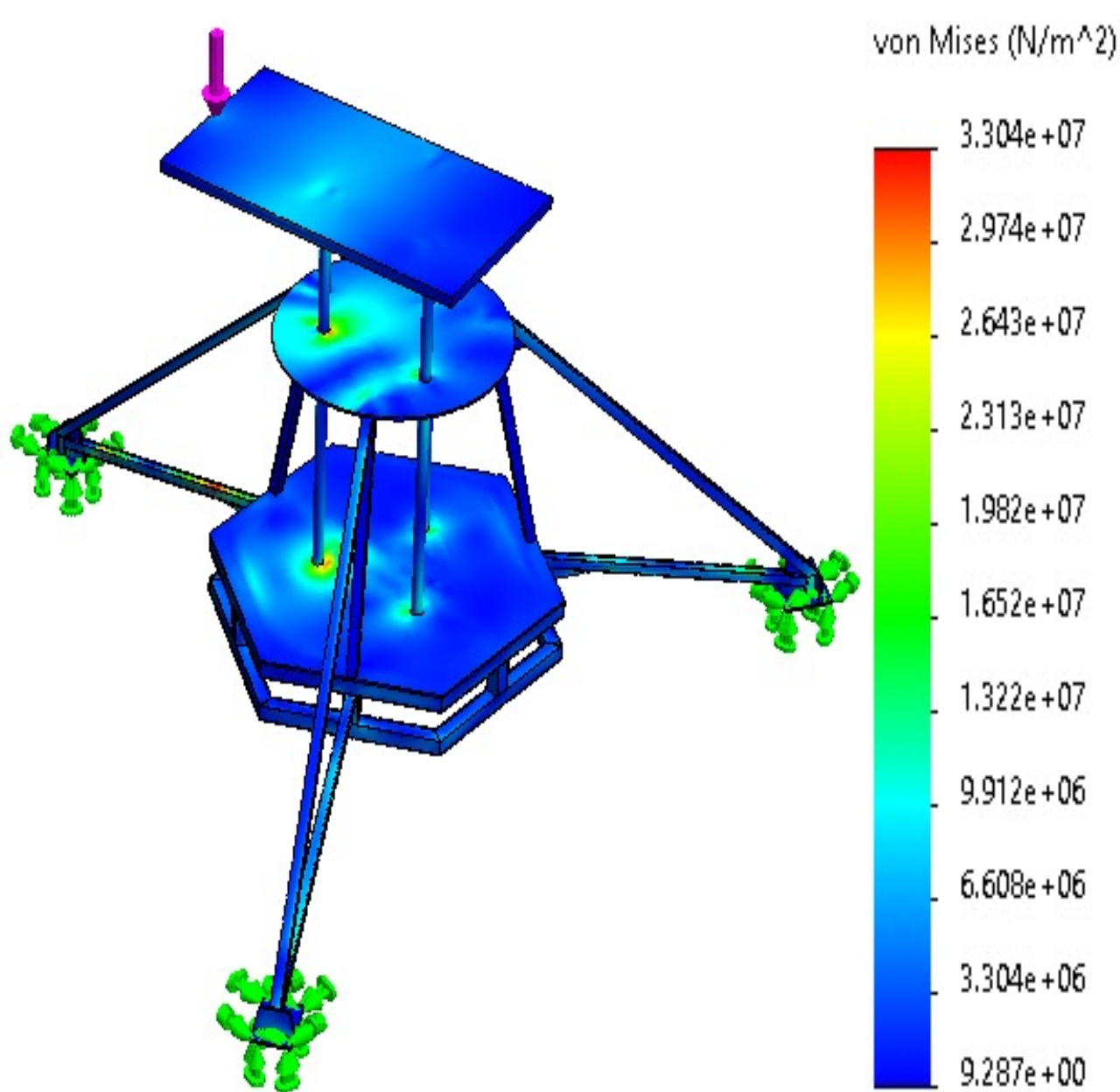

Frame under bending load (225 lb)

Prototype



Frame under bending load (225 lb)

Electrical Block Diagram

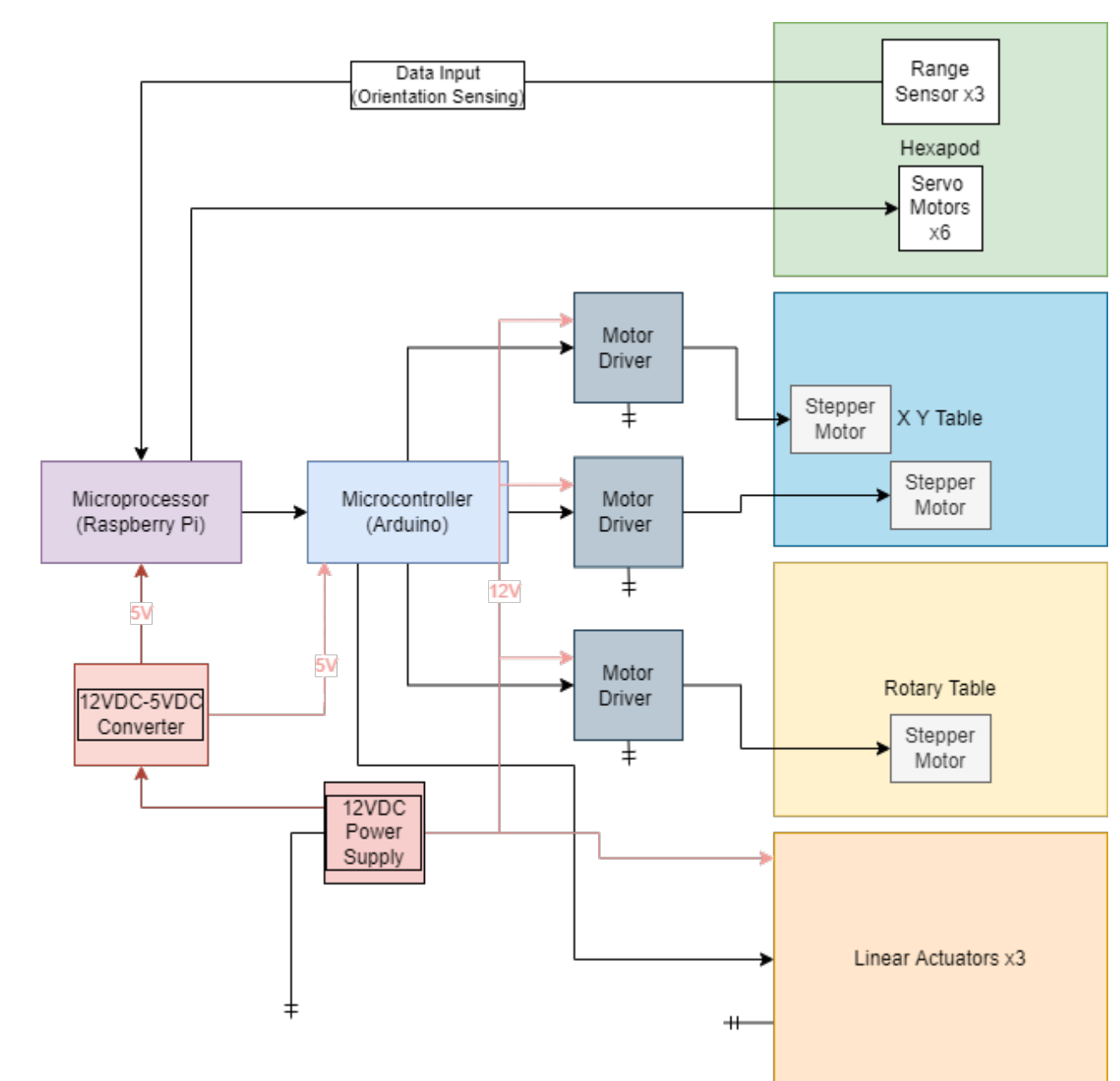

Conclusion

The main objective of the Automated Self-Leveling Tool project is to design a stand that is autonomous to support a deployed appendage without imparting loads on the hinge of the deployed appendage. To do so, the Automated Self-Leveling Tool is designed to level a 3"x5" plate at the very top of the Automated Self-Leveling Tool to the 3"x5" plate at the bottom of 150lb appendage. The Automated Self-Leveling Tool will level and adjust to mate these 3x5 plates using high precision positioning systems, such as the linear actuators, rotary plate, XY plate, and the hexapod. The subsystems chosen for the concept design fulfill all the given requirements, whereas the prototype will not be able to meet the given requirements but convey proof of concept. However, the base can withstand the imparted loads and has a factor of safety of 11 under bending.

Acknowledgments



Thank you to our faculty advisor Everardo Hernandez, and our Boeing advisors: Teofilo El Masri, Jacqueline Martinez, Jonathan Fish for all their help and support. And a special thank you to the ECST makerspace for allowing us to utilize the facility to build our prototype.