



CAL STATE LA
CALIFORNIA STATE UNIVERSITY, LOS ANGELES



Jet Propulsion Laboratory
California Institute of Technology

Project 6: Venus Wind Harvester

Group Members:

Saul Loza	Kevin Pan	Oscar Lopez
Zacharias Garza	Jonathan Serrano	Anthony Izaguirre

Faculty Adviser:

Dr. Jim Kuo

Client

Dr. Jonathan Sauder

Agenda

- | | |
|---------------------------|----------------------------|
| 1. Introduction | Saul Loza |
| 2. Methodology | Kevin Pan |
| 3. Experimental Testing | Jonathan Meza Serrano |
| 4. Results & Validation | Zacharias, Anthony & Kevin |
| 5. Revised Water Test Bed | Oscar Lopez |
| 6. Conclusion | Anthony Izaguirre |
| 7. Future Plans | Saul Loza |

Introduction

- Why Venus?
- Earth's sister-planet
- Relatively unknown
- Possible microbial life

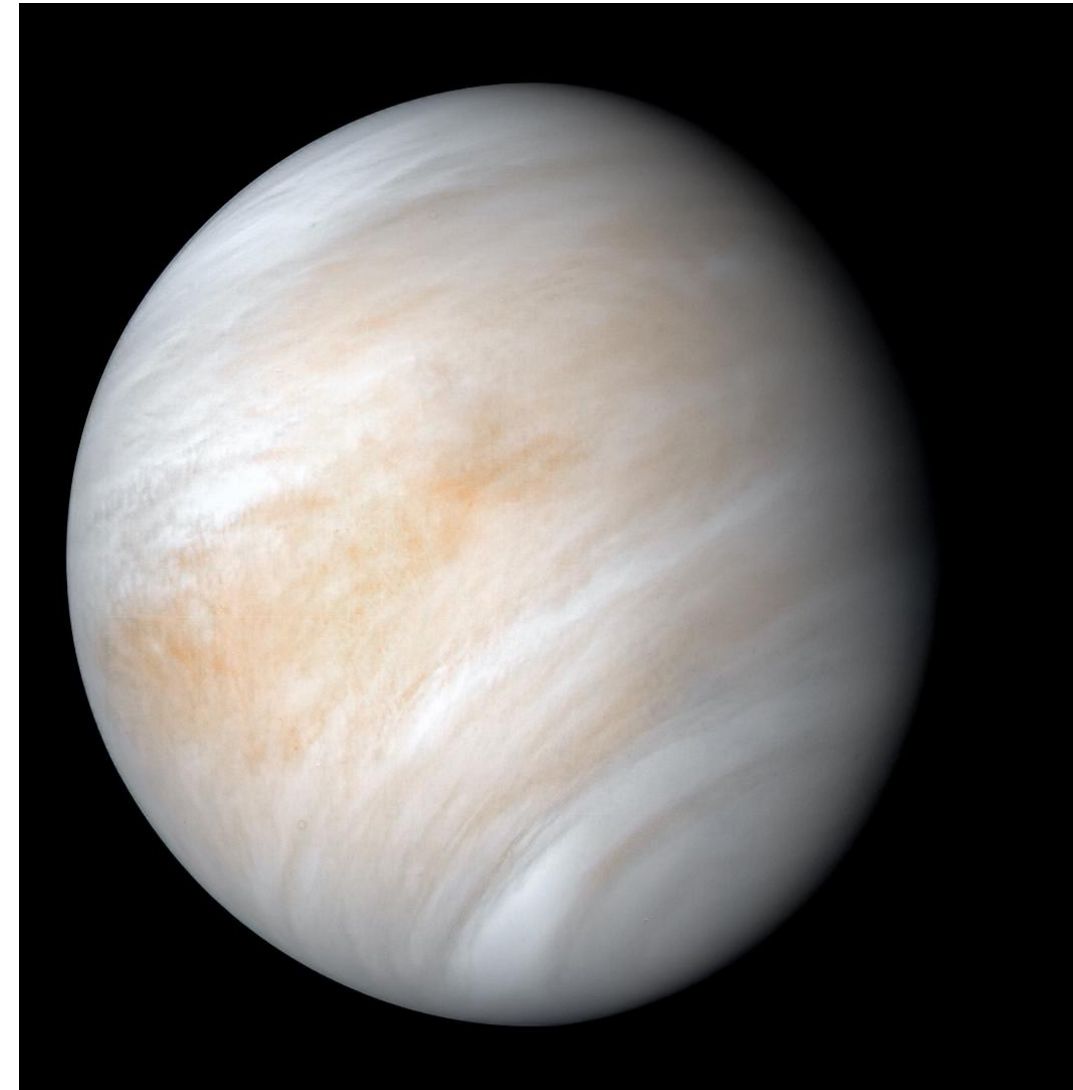

Figure 2: Image of Venus from outer space.

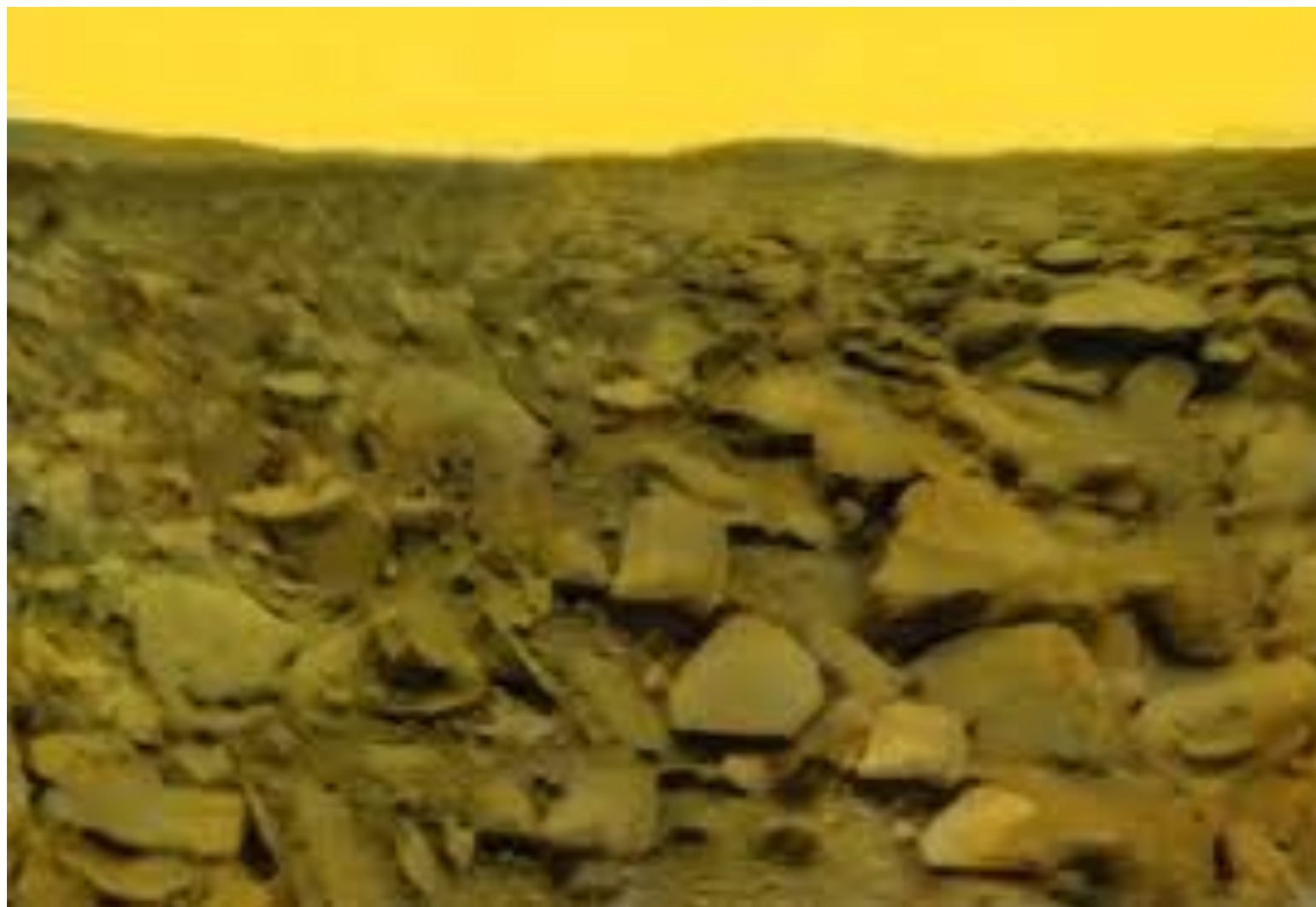

Figure 1: Image of Venus from the surface

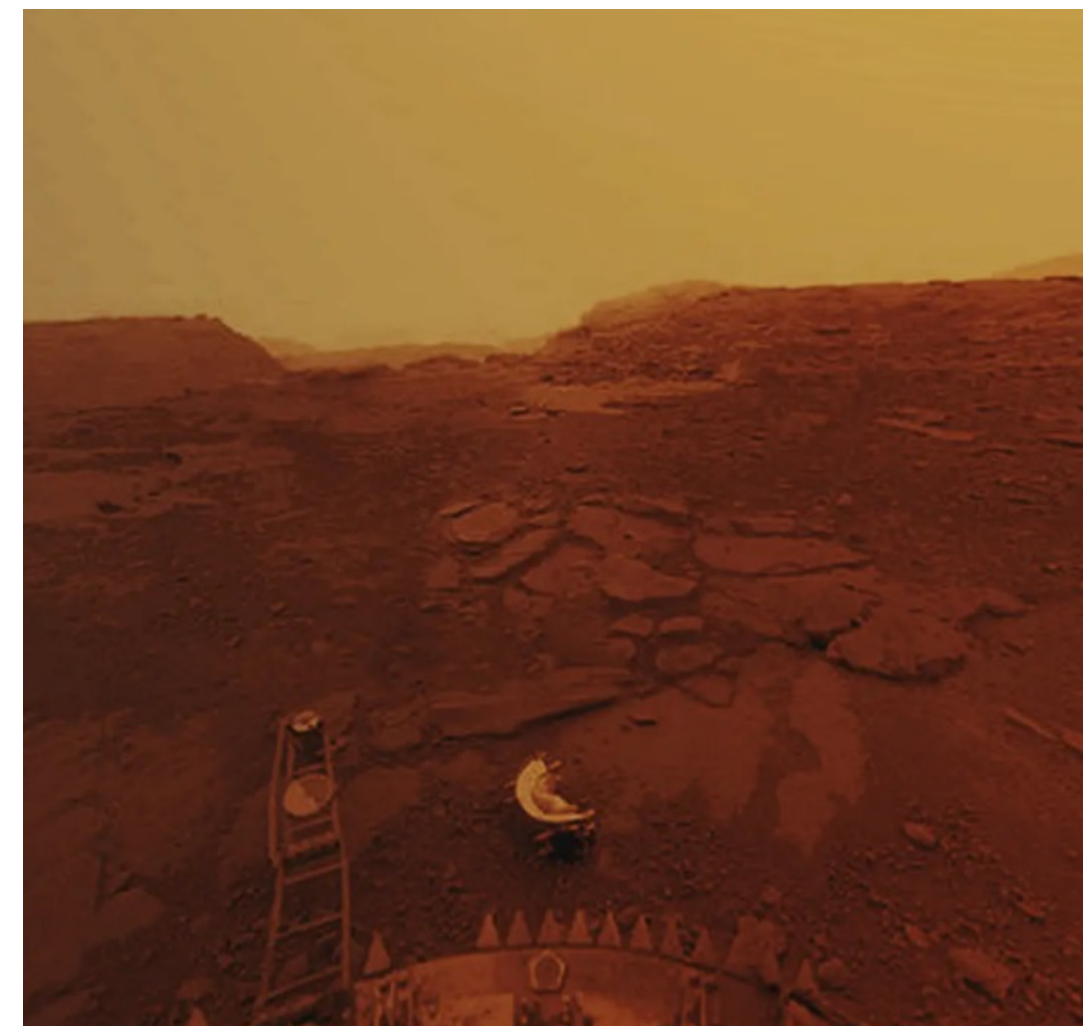

Figure 3: Image of Venus from the surface

NASA/JPL Venus Mission: AREE



Figure 4: Rendering of possible Venus Rover Design [1]

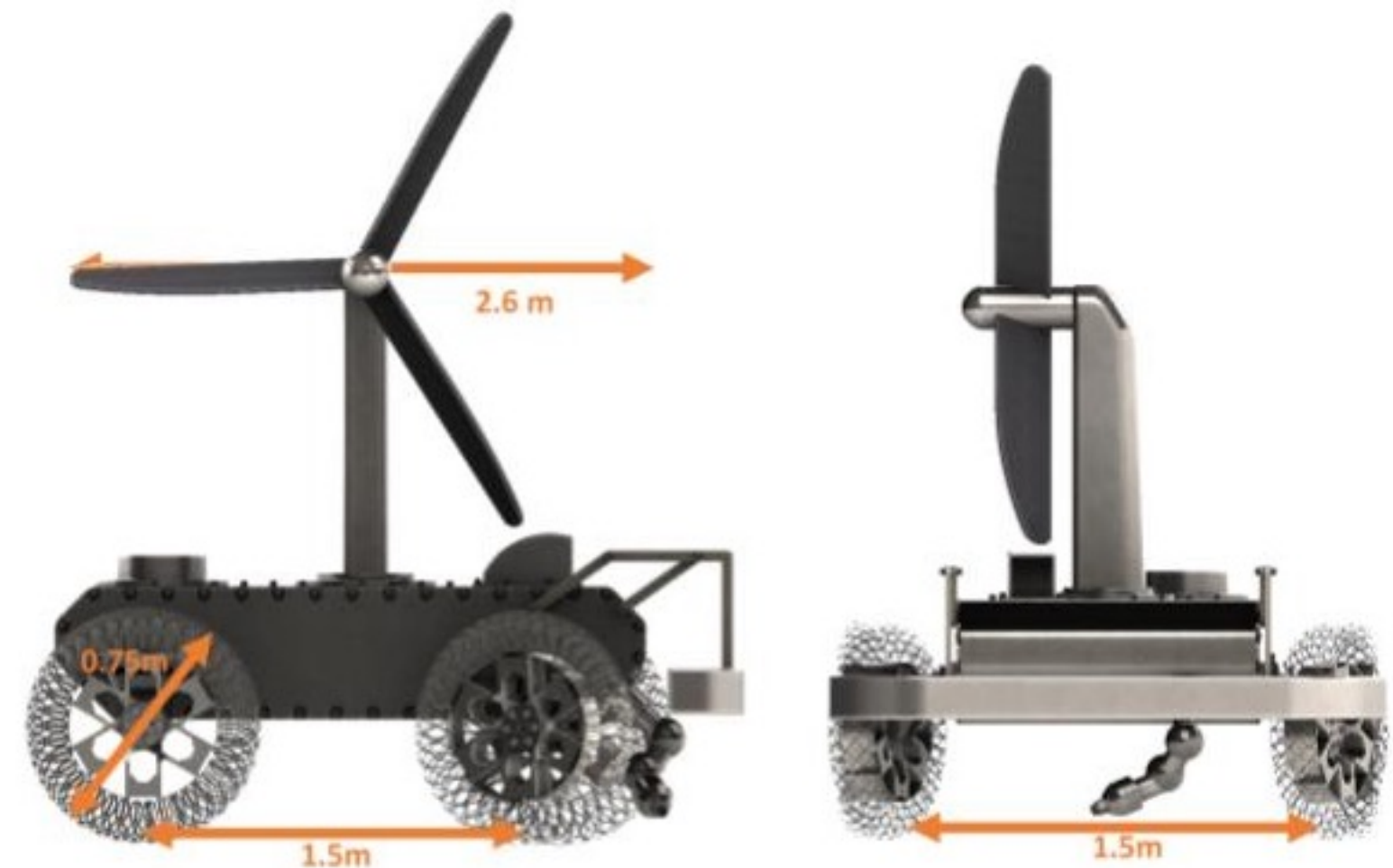

Figure 5: Front and side view of possible Venus Rover Design. [2]

- Completely mechanical system
- Venus average surface temperature $\approx 425^{\circ}\text{C}$
- Alternate energy source: Wind Turbine

Objective/Project Requirements

Table 1: Project Requirements and Parameters

Requirements	Requirement Values
Storing Cylinder Constraints	2.7 m (diameter) x 0.5 m (thickness)
Mass	< 45 kg
Power Generated at $0.6 \frac{m}{s}$ (Venus)	9 W
Efficiency	$\geq 40 \%$
Wind Speed Range (Venus)	$(0.3 \frac{m}{s} - 1.3 \frac{m}{s})$
Budget	< \$1,000

Agenda

- | | |
|---------------------------|----------------------------|
| 1. Introduction | Saul Loza |
| 2. Methodology | Kevin Pan |
| 3. Experimental Testing | Jonathan Meza Serrano |
| 4. Results & Validation | Zacharias, Anthony & Kevin |
| 5. Revised Water test bed | Oscar Lopez |
| 6. Conclusion | Anthony Izaguirre |
| 7. Future Plans | Saul Loza |

Methodology

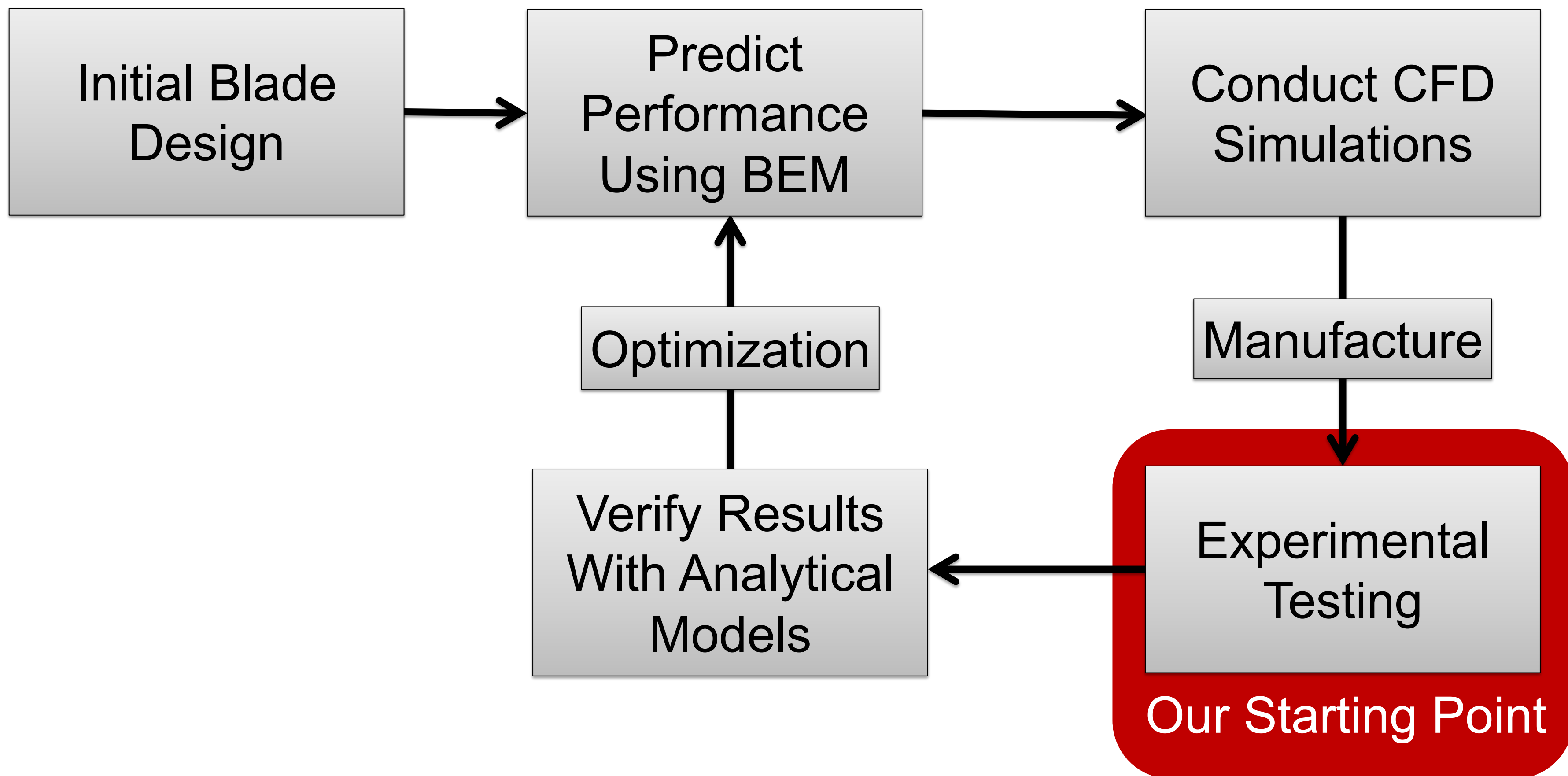

Methodology

- Fourth Year of Project
- Past Team's Work
 - Turbine Design Methodology
 - Turbine Design Optimization
 - Wind Tunnel Testing
 - Preliminary Water Testing

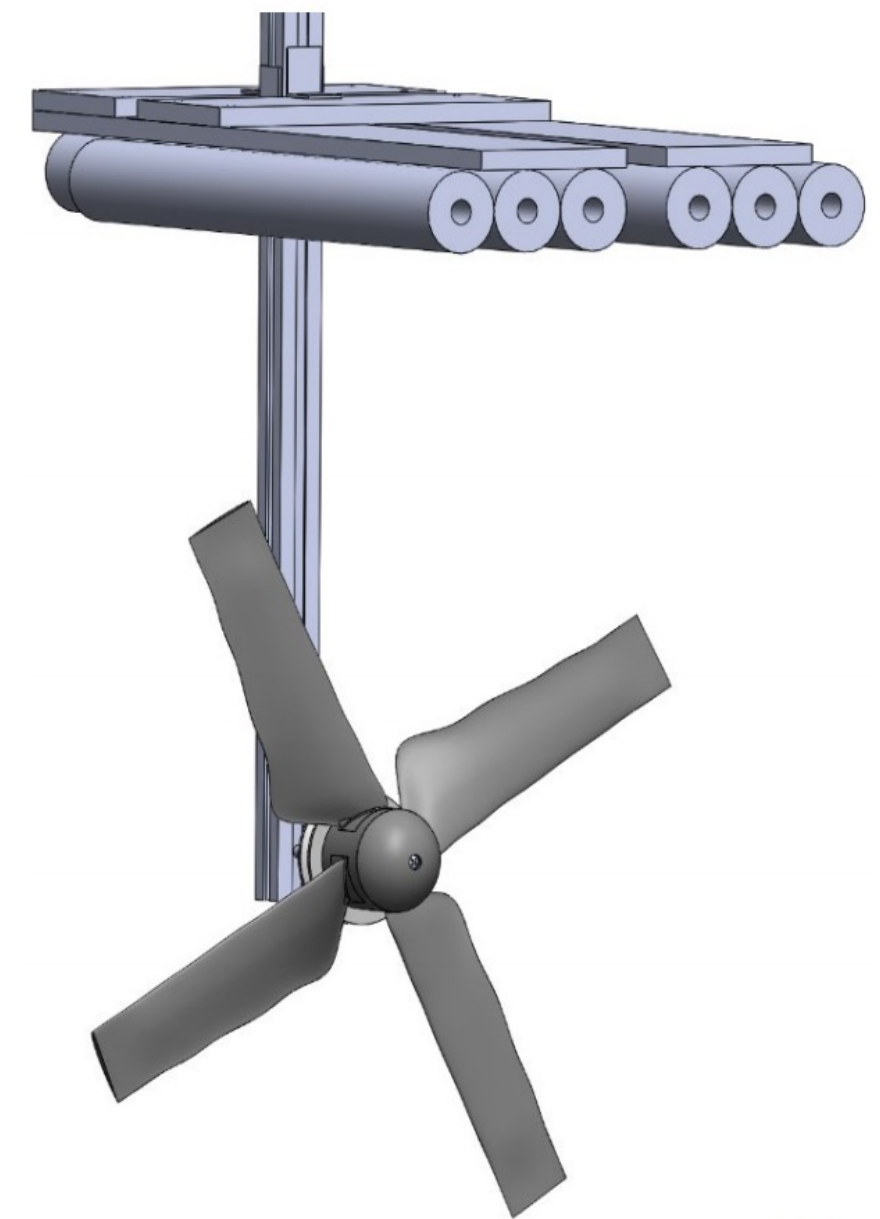

Figure 6: (Top) wind tunnel testing,(Bottom) 19-20 CAD design

Agenda

- | | |
|---------------------------|----------------------------|
| 1. Introduction | Saul Loza |
| 2. Methodology | Kevin Pan |
| 3. Experimental Testing | Jonathan Meza Serrano |
| 4. Results & Validation | Zacharias, Anthony & Kevin |
| 5. Revised Water test bed | Oscar Lopez |
| 6. Conclusion | Anthony Izaguirre |
| 7. Future Plans | Saul Loza |

2020-2021 Test Requirements

- Previous Design Problems
 - Fluid velocity
 - Stationary
- Method to measure fluid velocity
- Method to measure torque
- Method to pulley rpm

CAD Design

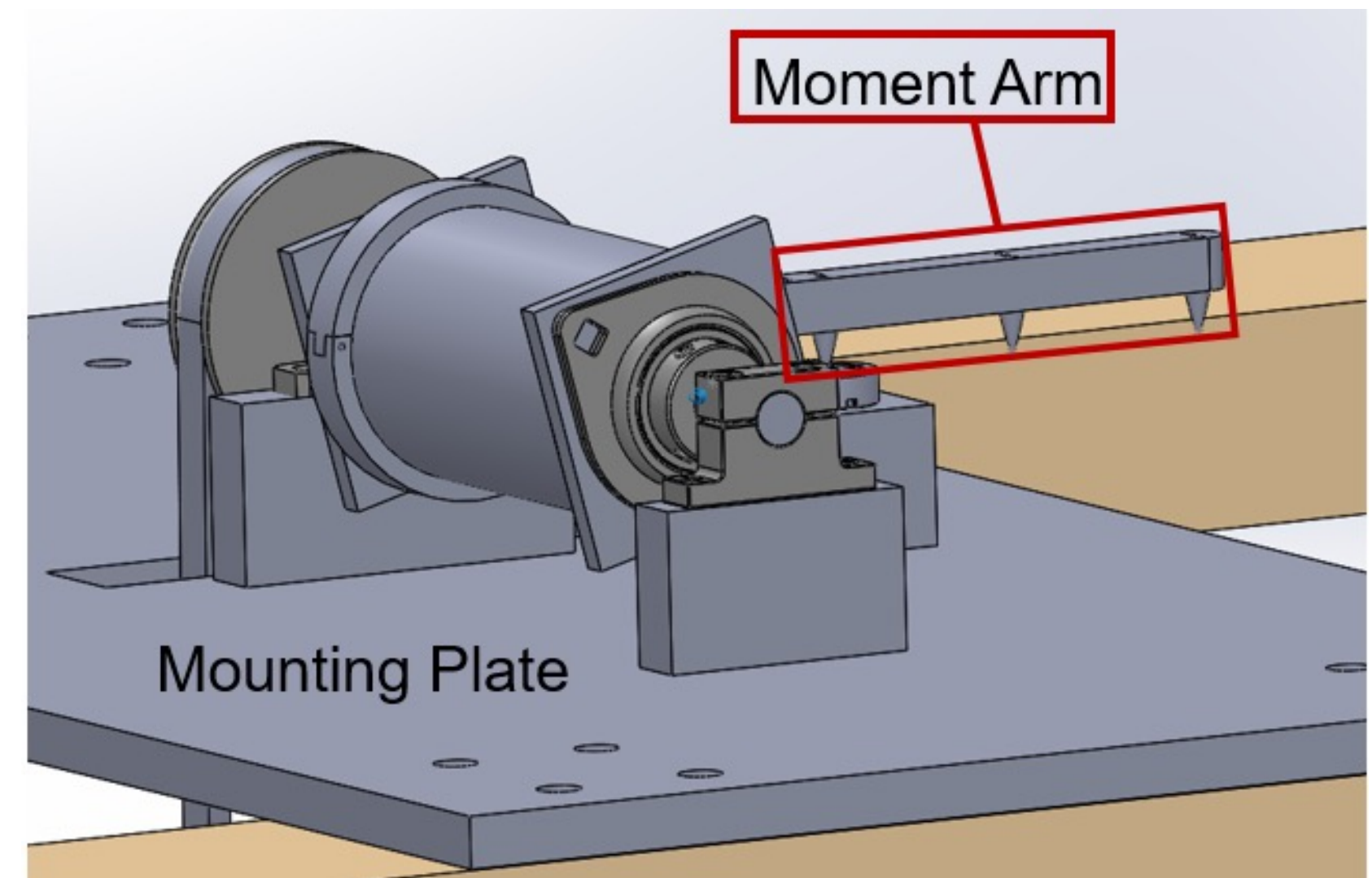
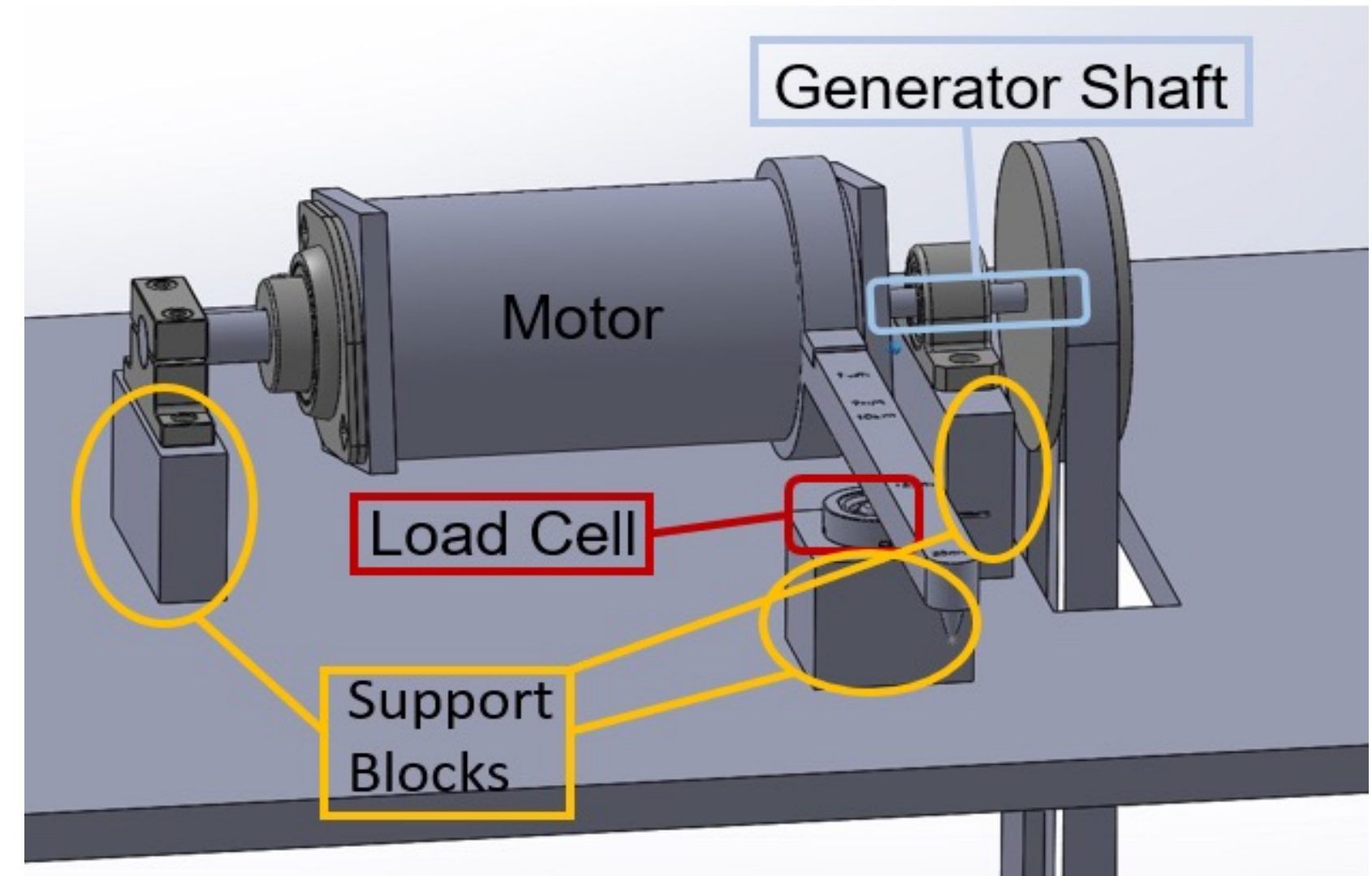
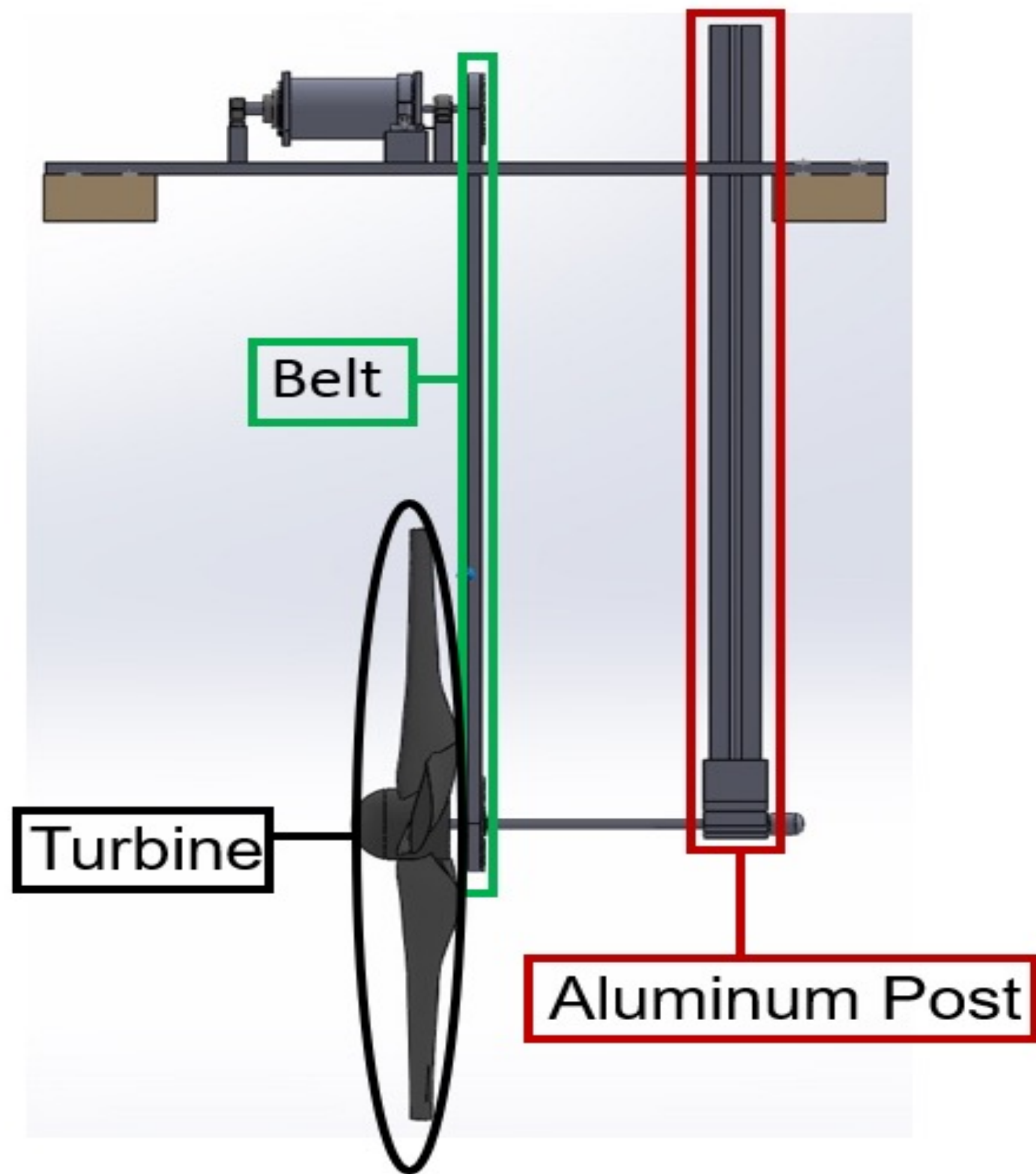

Figure 7: (Left) Side view of winter testing CAD design, (Top right) Side view of mounting plate CAD design, (Bottom right) Rear view of mounting plate CAD design.

CAD vs Testing Design

- This year's test set up CAD

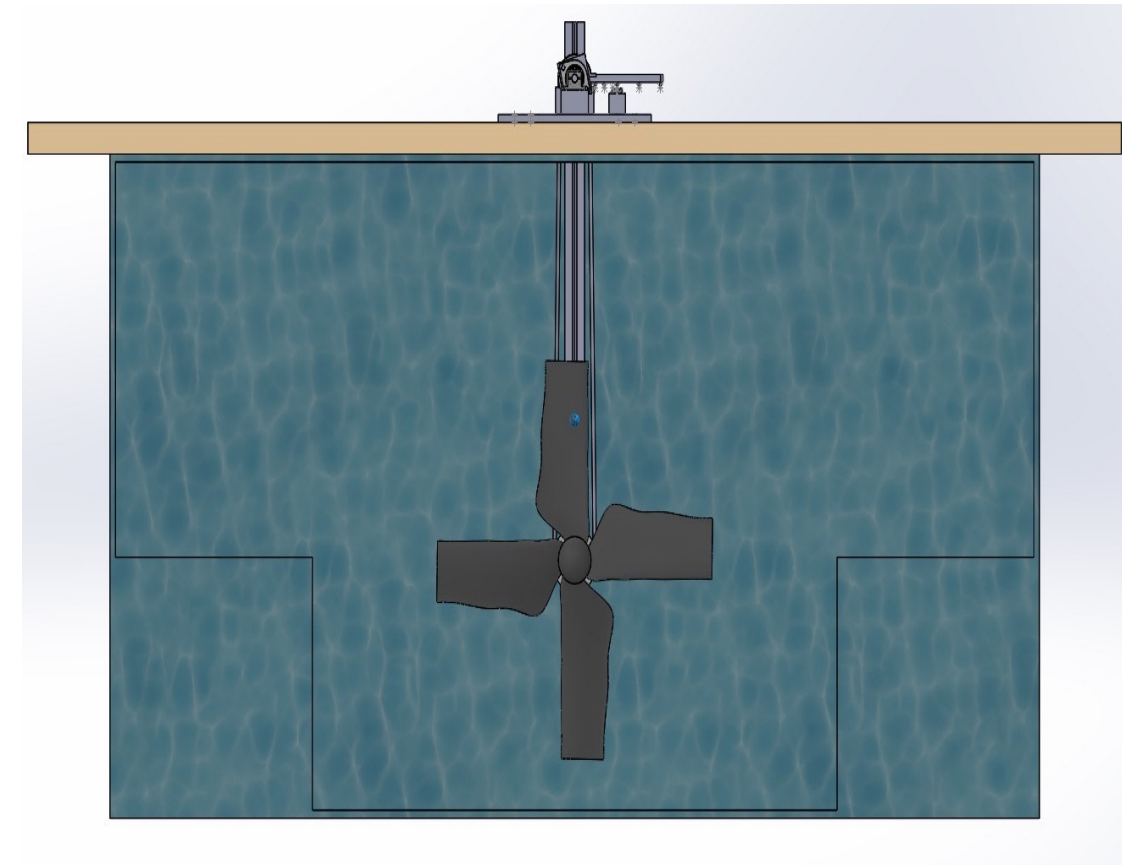
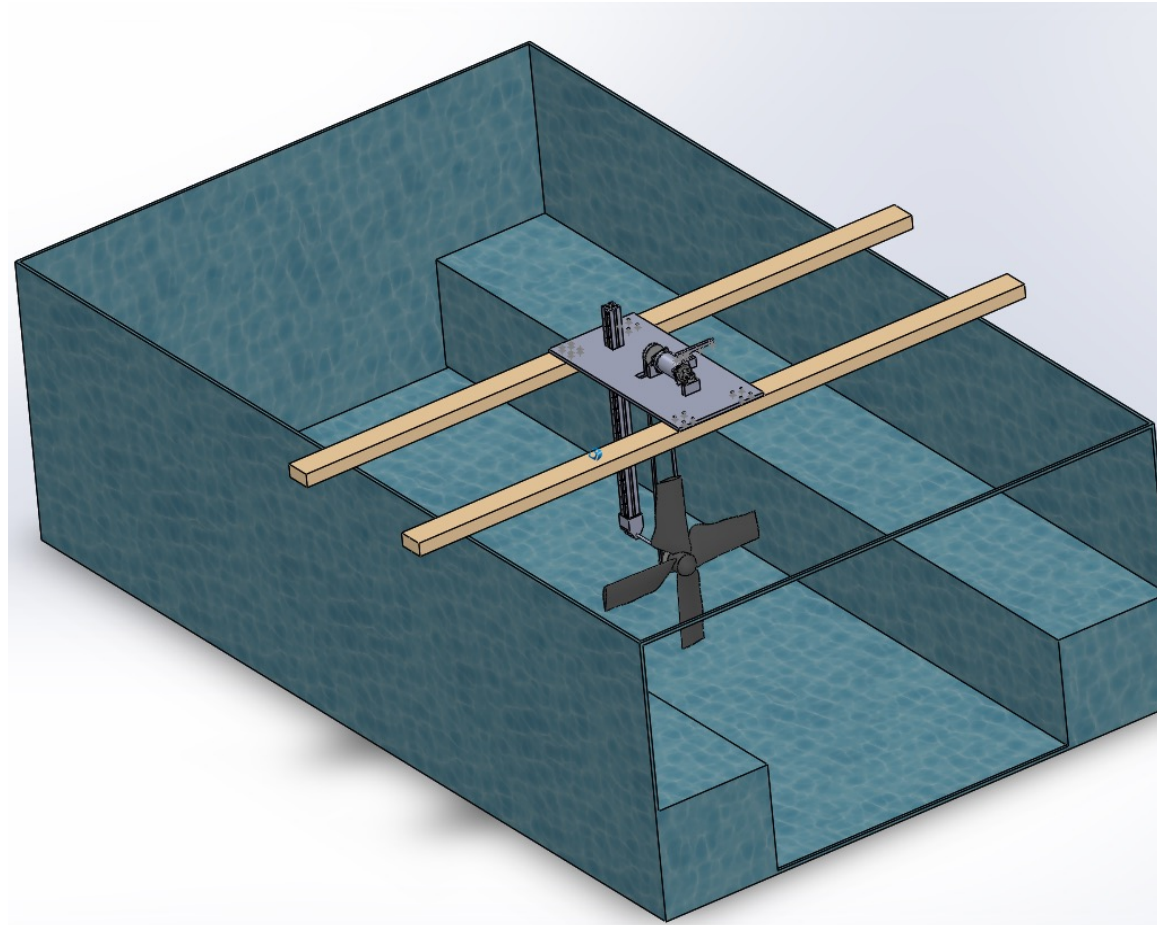

Figure 8: CAD design of turbine placement

- Stationary design during testing

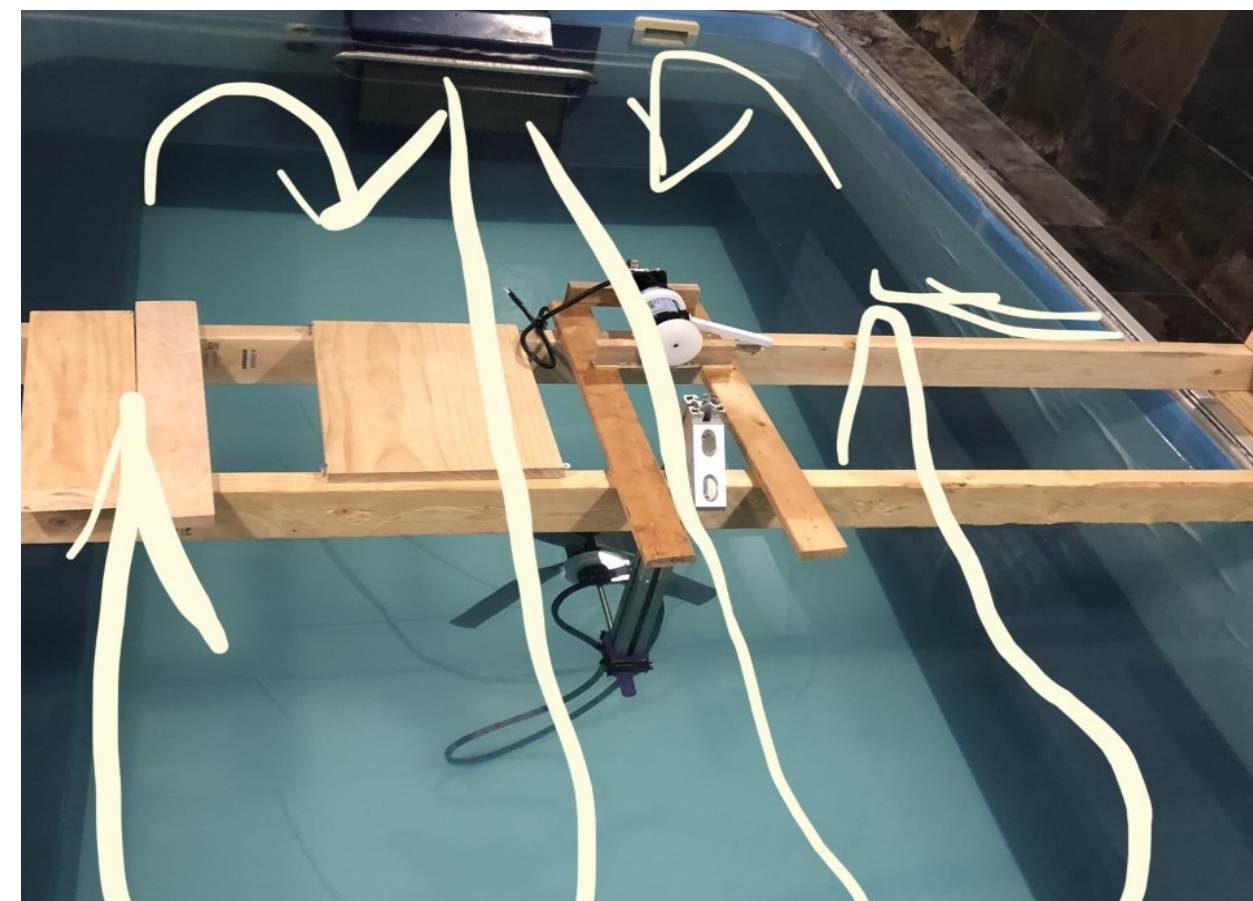
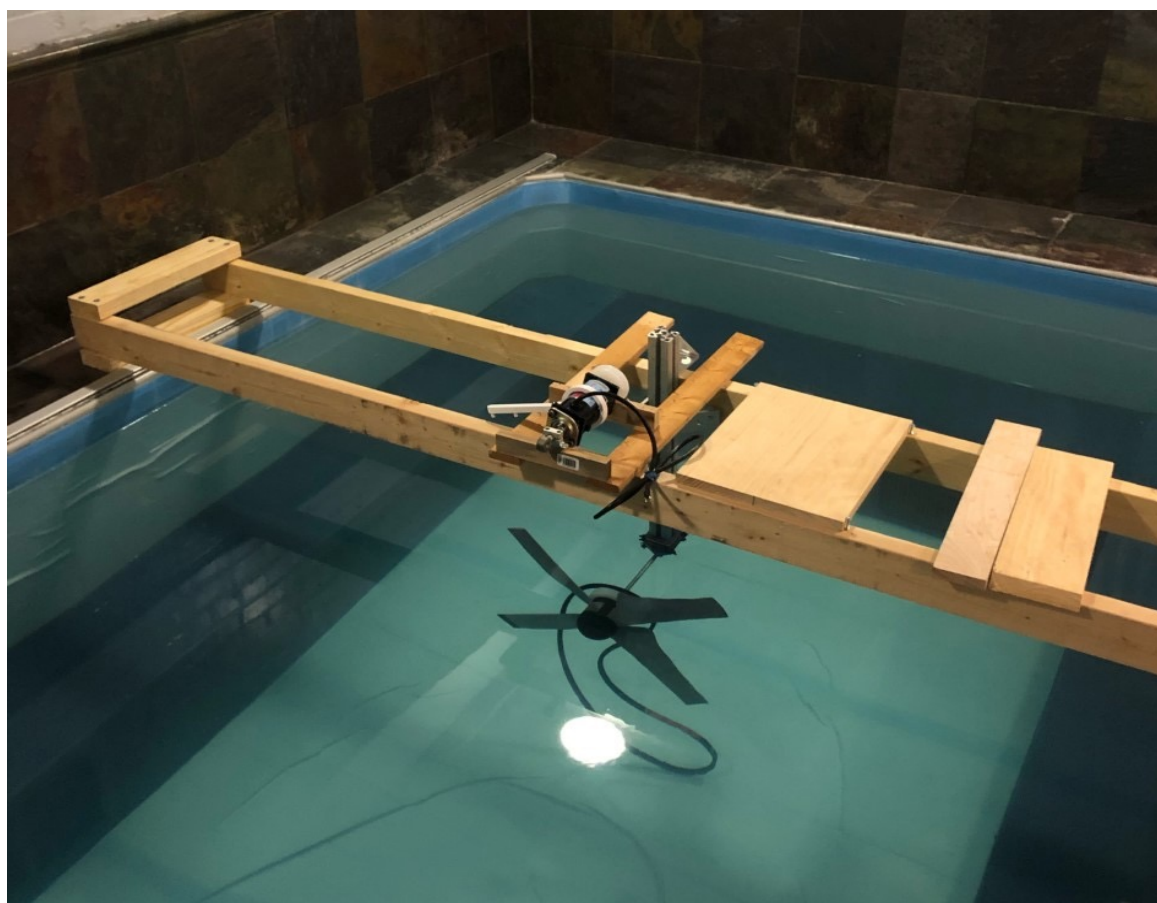
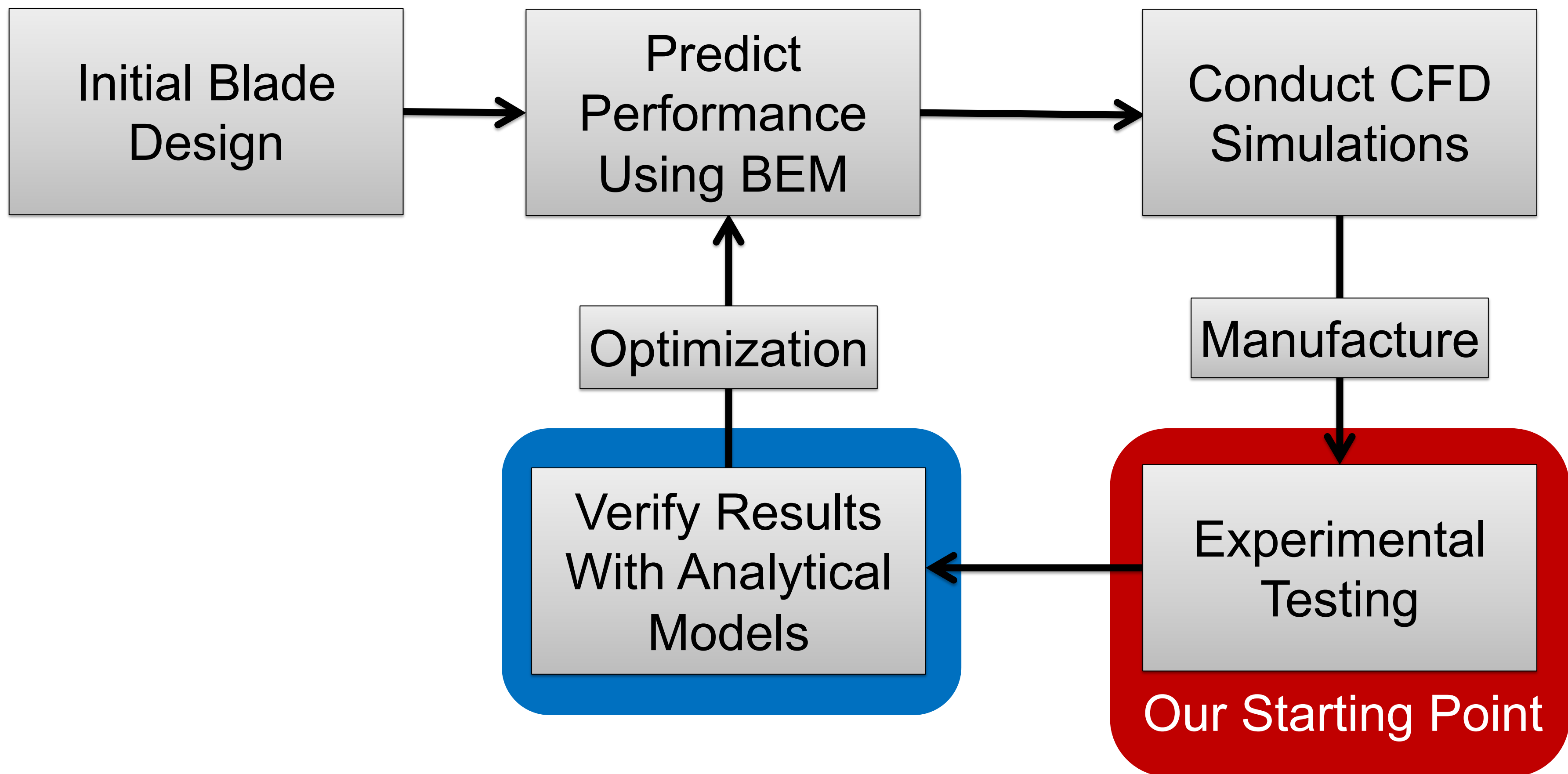

Figure 9: Winter testing setup and placement of turbine

Agenda

- | | |
|---------------------------|----------------------------|
| 1. Introduction | Saul Loza |
| 2. Methodology | Kevin Pan |
| 3. Experimental Testing | Jonathan Meza Serrano |
| 4. Results & Validation | Zacharias, Anthony & Kevin |
| 5. Revised Water test bed | Oscar Lopez |
| 6. Conclusion | Anthony Izaguirre |
| 7. Future Plans | Saul Loza |

Methodology



Theory

Tip Speed Ratio

$$\text{TSR} = \frac{\text{Tip Rotational Speed}}{\text{Velocity of Wind}}$$

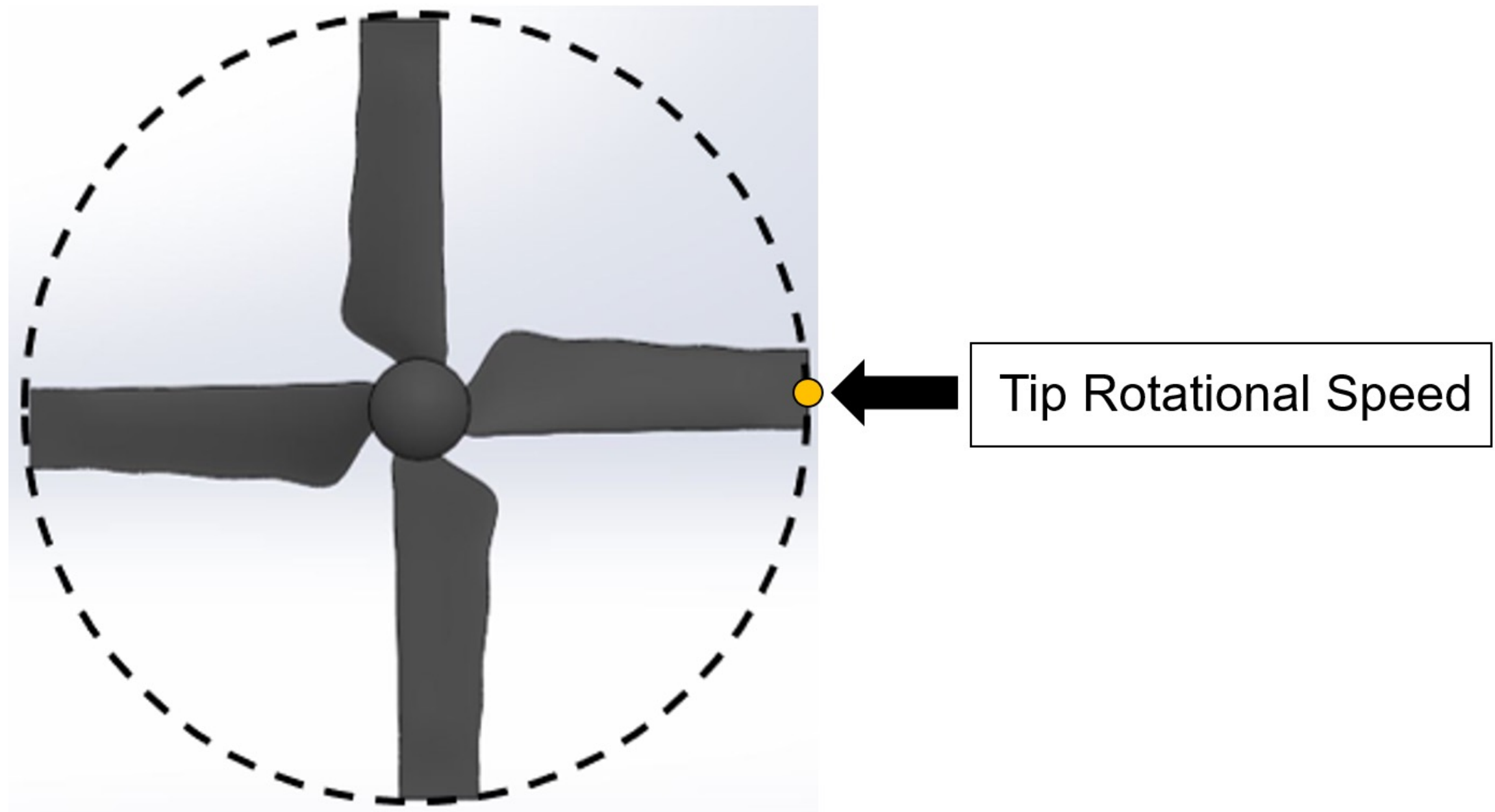

Figure 10: Definition of tip speed ratio

Water Testing Results

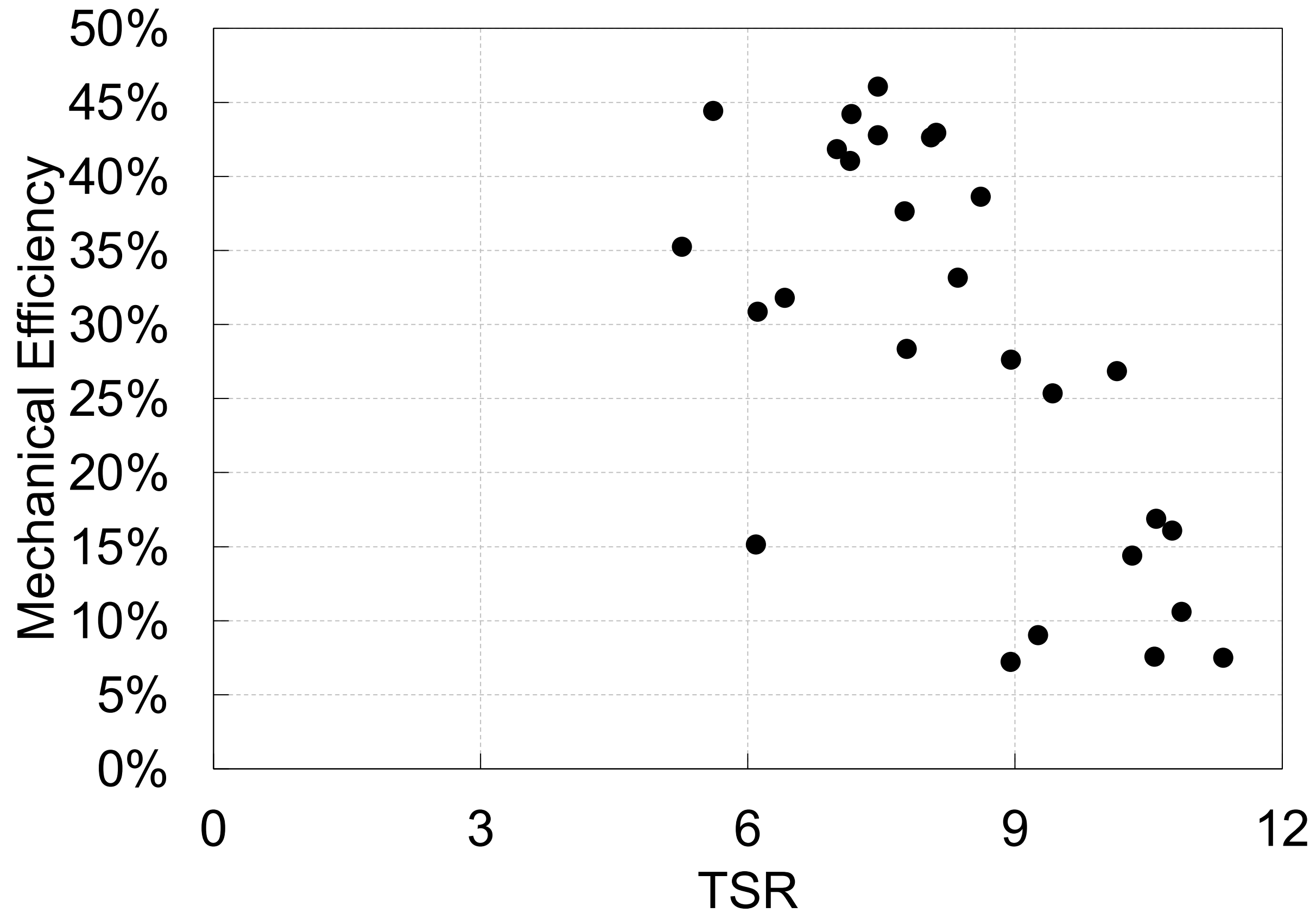

Figure 10: Mechanical efficiency based on TSR values obtained during winter testing

Blade Element Momentum Theory (BEM)

Relates blade shape to the rotor's ability to extract power from the wind

- Analysis of forces at section of blade as a function of blade geometry
 - Expressed as a function of lift and drag coefficients and angle of attack (angle between chord and relative wind)
- Defines the normal (thrust) and tangential (torque) forces on the annular rotor section as a function of the flow angles

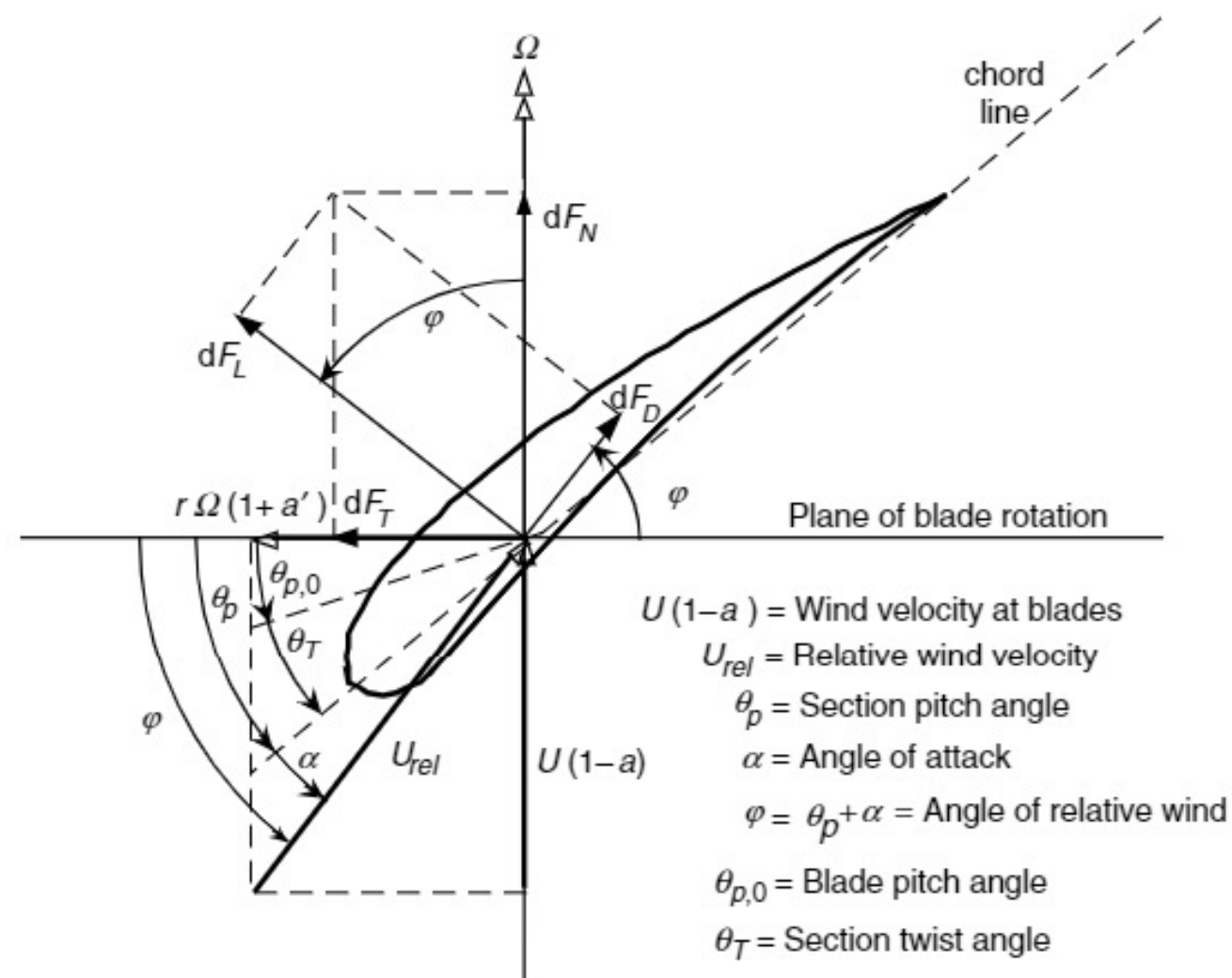

Figure 11: Blade geometry for analysis of a horizontal axis wind turbine.

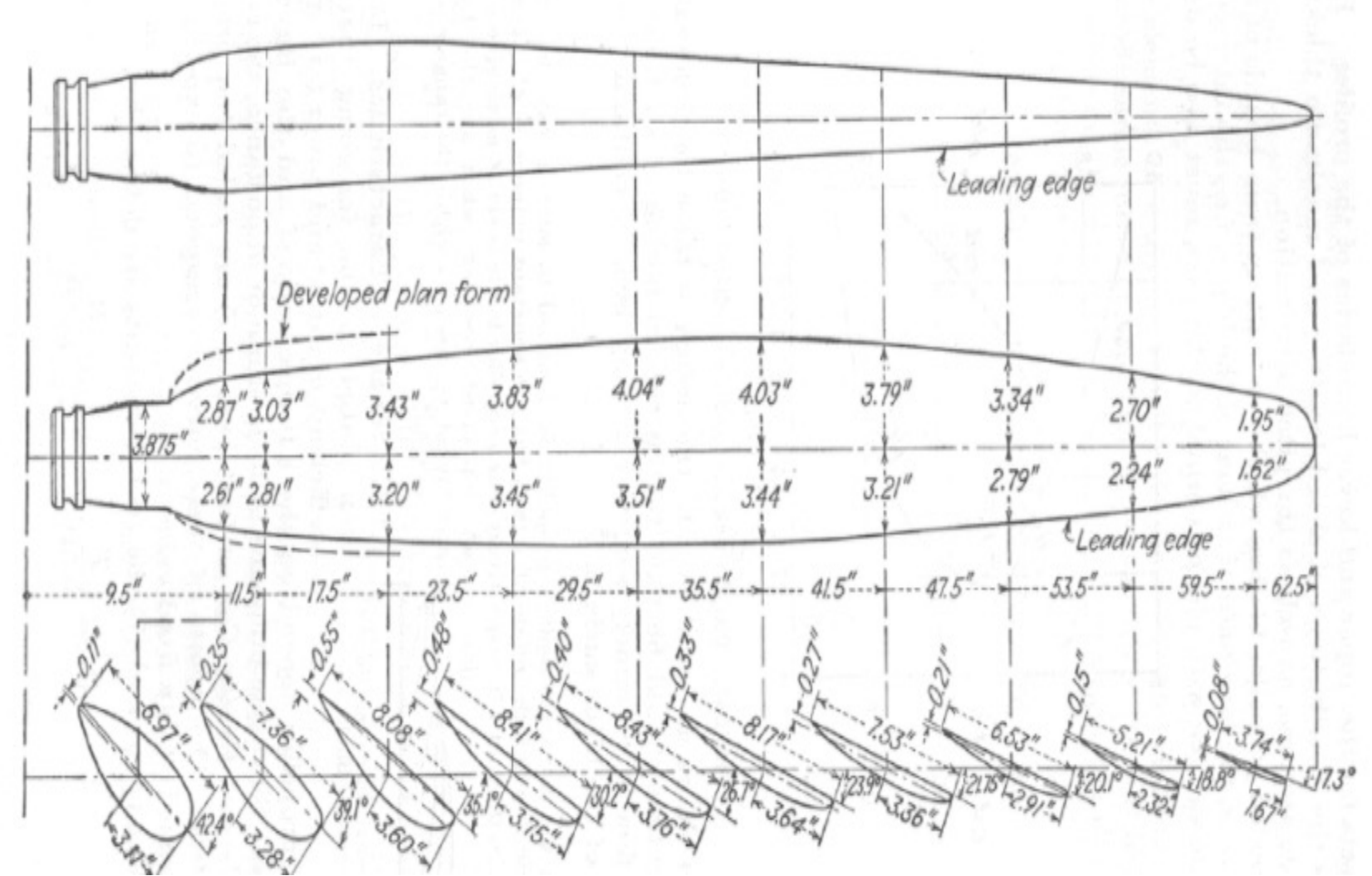

Figure 12: Sectioned blade of a horizontal axis wind turbine.

BEM Analysis

- Matlab code to perform calculations based on BEM theory to understand expected results from experimental testing
- Used to validate experimental data

Table 2: Theoretical turbine output from BEM theory compared to experimentally observed turbine output during water testing

Experimental				Theoretical			
Average Fluid Velocity (m/s)	RPM	Mechanical Efficiency	Power (W)	Mechanical Efficiency	Percent Difference	Power (W)	Percent Difference
0.53	120	0.442	9.852	0.319	38.51%	7.907	24.59%
	125	0.461	10.263	0.313	47.18%	7.751	32.41%
	125	0.428	9.529	0.313	36.67%	7.751	22.94%
	130	0.376	8.386	0.304	23.91%	7.523	11.48%
	135	0.426	9.500	0.292	45.90%	7.239	31.24%
	140	0.332	7.389	0.275	20.44%	6.820	8.34%
	150	0.276	6.158	0.207	33.85%	5.110	20.51%
	170	0.269	5.982	-0.819	132.78%	-20.285	128.24%

Computational Fluid Dynamics (CFD) Analysis

- CFD – Ansys Fluent Software
- Viscosity Model: SST $k-\omega$
- Control Volume setup
- Mesh Generation

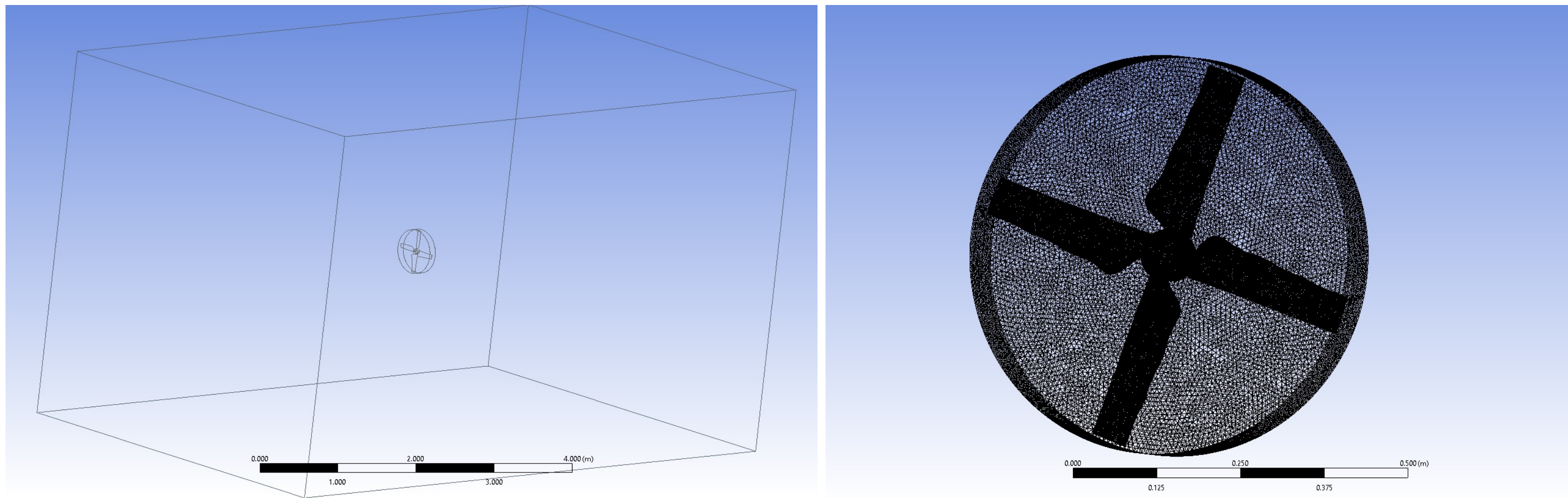

Figure 13: Current model Setup and Tetrahedra Mesh on Turbine

Agenda

- | | |
|---------------------------|----------------------------|
| 1. Introduction | Saul Loza |
| 2. Methodology | Kevin Pan |
| 3. Experimental Testing | Jonathan Meza Serrano |
| 4. Results & Validation | Zacharias, Anthony & Kevin |
| 5. Revised Water test bed | Oscar Lopez |
| 6. Conclusion | Anthony Izaguirre |
| 7. Future Plans | Saul Loza |

Improvements on Test Setup

- Winter Testing Had Issues
 - Uncharacterized motor
 - Pulley slipping
 - Wrong size shaft bearing
- Refinement Necessary
 - Update data acquisition
 - Slipping issue corrected
 - New characterized motor
 - New motor housing
 - Updated moment arm assembly



Figure 14: (Top) Data acquisition, (Center) , (Bottom) New motor.



Improvements To The Test Setup

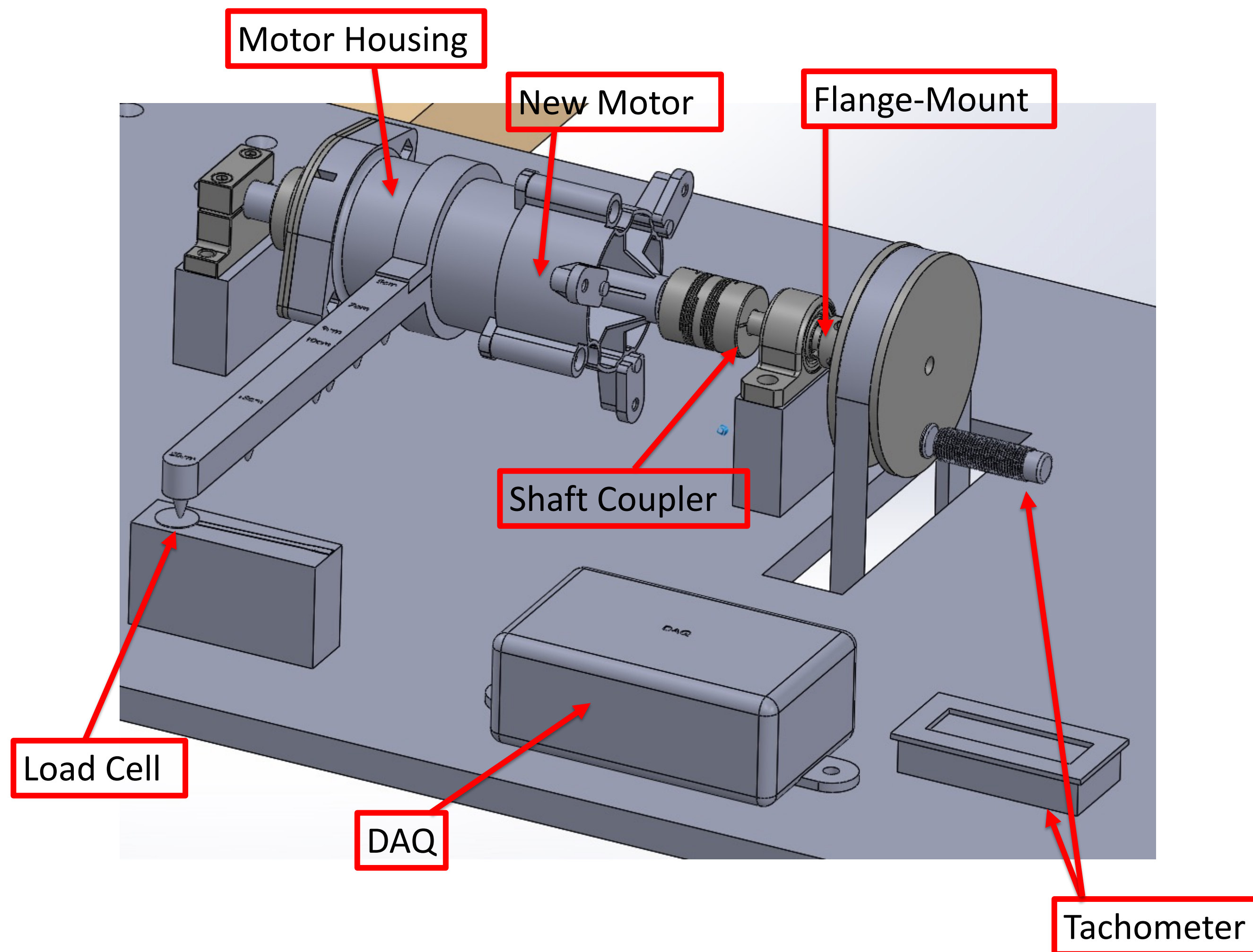

Figure 15: CAD design highlighting the improvements made based on the issues experienced during winter testing and the data obtained.



Final Bill Of Materials

Table 3: Bill of materials for the senior design project of fall 20-21.

ITEM NO.	Materials	DESCRIPTION	QTY.	Price
1	(6383K215) Ball Bearing	Bearing Between Pulley and Hub	1	Inherited
2	Aluminum Post	Turbine Support	1	Inherited
3	DC Generator		1	Inherited
4	Generator Shaft		1	Inherited
5	MoldAdTSh	Connects turbine shafts to aluminum post	1	Inherited
6	(6274K21) Generator Pulley		1	Inherited
7	(6274K26) Turbine Pulley		1	Inherited
8	Turbine Blade and Hub		1	Inherited
9	Belt		1	Inherited
10	Single Tact Load Cell		1	Inherited
11	Breadboard		1	Inherited
12	Mounting Plate		1	Donated
13	Turbine Shaft		1	Donated
14	TwoByFour		2	Donated
15	(1865K3) Base Mounted Shaft Support	Supports generator rear shaft	1	Donated
16	Pool	Test Endless-pool	1	Donated
17	Wood Screws	Connects mounting plate to two by fours	16	Donated
18	Flow Meter Rental		1	Donated
19	Bearing Support	Roller Bearing Support	1	Fabricated
20	Moment Arm Bottom		1	Fabricated
21	Moment Arm Top		1	Fabricated
22	Shaft Bearing		1	27.94
23	Open Extended Gusset	5537T661	4	52.4
24	Single Nut with Button Head	5537T163	1	5.86
25	Rear motor mount	5913K71	1	11.33
26	Easy-Access Base	1865K3	1	18.45
27	Load Cell	FX1901-0001-0200	1	32.82
28	Data Acquisition	DI -1100	1	59
29	Rod End Bolt Blank	6065K321	1	12.37
30	Electrical Load	100W 1K ohm Potentiometer	1	27.36
31	Amplifier		1	21.99
32	Motor	Brushless DC Motor	1	23.99
33	Rotary Shaft Extender	1265K64	1	20.55
34	Flange mount	9624T16	1	75.42
35	Coupler	2463k28	1	51.13
36	Tacometer	Megnetic Tachometer	1	24.99
Total Cost				293.51



Updated Setup

- Updated Motor Assembly

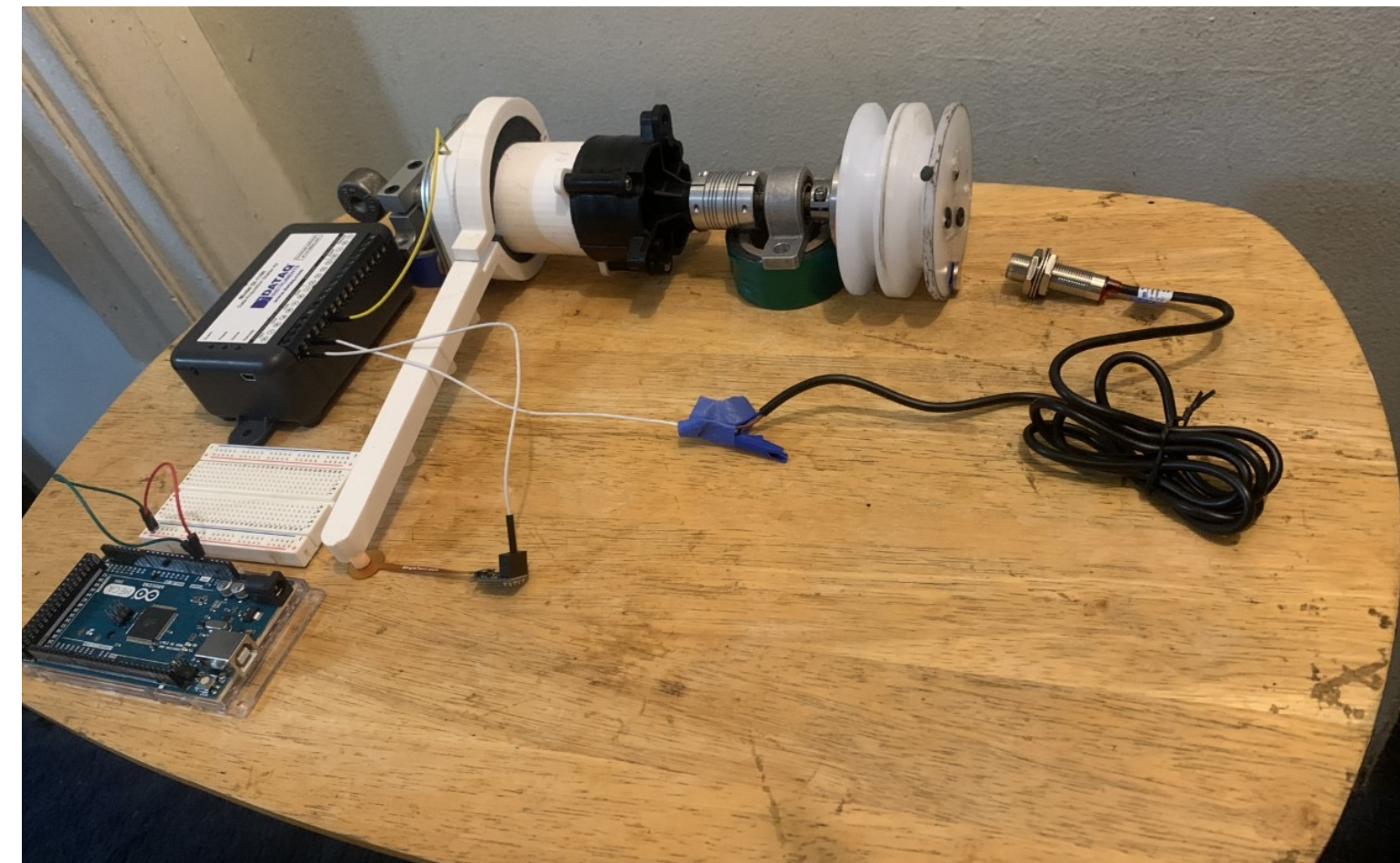
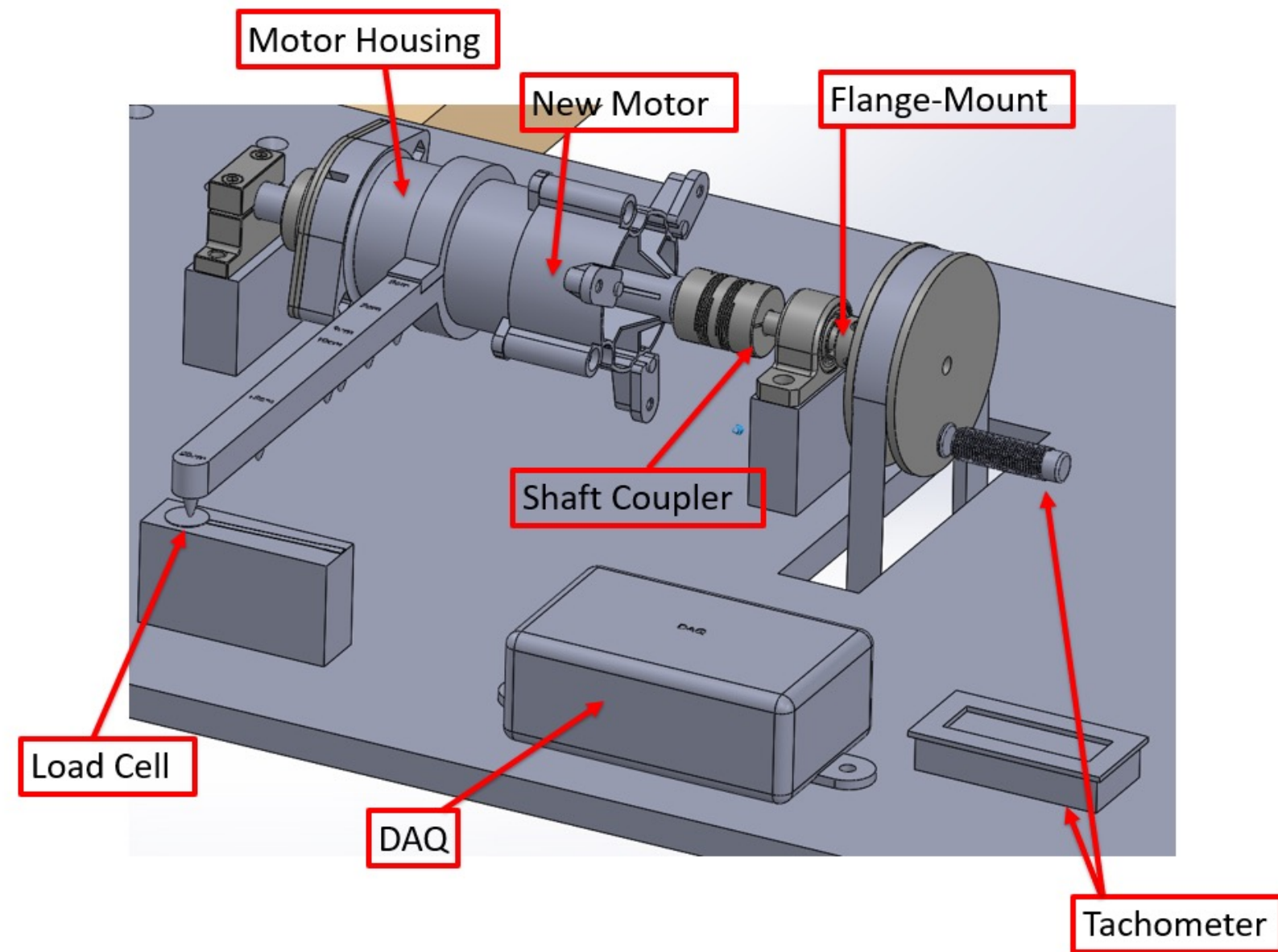

- Updated CAD design made testbed build straight forward

Figure 16: Comparison between the improved CAD design and actual improved design.

Agenda

- | | |
|---------------------------|----------------------------|
| 1. Introduction | Saul Loza |
| 2. Methodology | Kevin Pan |
| 3. Experimental Testing | Jonathan Meza Serrano |
| 4. Results & Validation | Zacharias, Anthony & Kevin |
| 5. Revised Water test bed | Oscar Lopez |
| 6. Conclusion | Anthony Izaguirre |
| 7. Future Plans | Saul Loza |

Conclusion

Table 4: Water Testing Result comparison to Requirement Values

Requirements	Requirement Values (Venus)	Performance Achieved In Water Testing
Storing Cylinder Constraints	2.7 m (diameter) x 0.5 m (thickness)	1:4 scale
Mass	< 45 kg	N/A
Power Generated at $0.6 \frac{m}{s}$ (Venus)	9 W	Max: 10.3 W
Efficiency	$\geq 40 \%$	Max: 46.1%
Wind Speed Range (Venus)	$(0.3 \frac{m}{s} - 1.3 \frac{m}{s})$	In Progress
Budget	< \$1,000	< \$1,000

Agenda

- | | |
|---------------------------|----------------------------|
| 1. Introduction | Saul Loza |
| 2. Methodology | Kevin Pan |
| 3. Experimental Testing | Jonathan Meza Serrano |
| 4. Results & Validation | Zacharias, Anthony & Kevin |
| 5. Revised Water test bed | Oscar Lopez |
| 6. Conclusion | Anthony Izaguirre |
| 7. Future Plans | Saul Loza |

Future Plans

- Continue to improve water testbed setup
 - Electrical/Mechanical braking system
- Optimize or redesign wind turbine blades
 - CFD and BEM simulation environments
- Future water testing
- More frequently available water testing environment

Thank you for your attention!

Any Questions?



CAL STATE LA

CALIFORNIA STATE UNIVERSITY, LOS ANGELES

References

- [1] Jet Propulsion Laboratory California Institute of Technology “Deadline Extended – Mechanical Maker Challenge: Mechanical Eye.” 31 March 2019 [Online]. Available: <https://www.jpl.nasa.gov/edu/events/2018/9/26/mechanical-maker-challenge-mechanical-eye/>
- [2] Dr. J. Sauder, “Requirements Summary,” Los Angeles, 2020
- [3] J. Manwell, J. McGowan and A. Rogers, *Wind Energy Explained*. Chichester: Wiley, 2009.